



Classroom Unit Ventilator Accessories

Accessories from A to Z

Wall Boxes, Energy Recovery System,
Shelving, Side Wall Exhaust, Gravity Relief
Damper





Introduction

Unit Ventilator Accessories from A to Z

As a leader in applied unit ventilator systems, Trane brings more than just an authentic approach for HVAC design to the drawing table. Trane also provides aesthetically pleasing solutions through their matching classroom accessories. Trane accessories are intended to complement the unit ventilator in order to provide a complete classroom system to the administrative staff.

Our full line of add-on accessories enhance the classroom unit ventilator system by affording a seamless approach to a classroom layout.

Trane's accessories include:

- Shelving
- Wall boxes

- Pipe covers
- Gravity relief damper (exhaust stale air naturally from the classroom).
- Side wall power exhaust system (exhaust stale air mechanically from the classroom).
- and Unit ventilator energy recovery system (treats and filters incoming fresh air into the classroom as well as exhausts stale air from the classroom).

Trane has over 80-years of application and design experience with indoor comfort system. Our offices are staffed with HVAC engineering professionals ready to work with you and your system designer to help determine the best solution for your school.



Table of Contents

Introduction	2
Features and Benefits	4
Application Considerations	9
Model Number Description	10
Shelving	10
Energy Recovery Ventilator	11
Side Wall Exhaust / Gravity Relief Damper	12
General Data	13
Performance Data	14
Electrical Performance	14
Controls	15
Energy Recovery Control Operation	15
Wiring	16
Dimensional Data	19
Mechanical Specifications	30



Features and Benefits

Energy Recovery Unit Ventilator

Energy Recovery Unit Ventilator

Air conditioning systems have always had one primary responsibility: deliver sufficient amounts of conditioned air into buildings. As indoor air quality issues grow proportionally, along with the rising cost of energy, more is being asked of these air conditioning systems.

To provide your facility with the best possible balance of energy efficiency, air quality and comfort, Trane offers an energy recovery unit ventilator.

The job of the unit ventilator energy recovery system is to provide every room with the right amount of fresh air necessary to comply with IAQ standards like ASHRAE 62, while minimizing installed cost and energy use. To do this, it uses a desiccant-coated wheel to transfer both sensible heat and moisture from outside air to exhaust air in the summer, and from exhaust air to the incoming outside air in the winter.

Traditionally, there has been a choice when bringing in outdoor air. Either locally, or through centralized ventilation systems. With the unit ventilator energy recovery system, the ductwork associated with centralized systems is eliminated, and possible humidity and energy consumption problems encountered when locally introducing outside air are also decreased.

Leading unit ventilator technology for decades, Trane has developed a unit ventilator that is as cost-effective, as it is IAQ-smart.

Equipment Size

The energy recovery system allows up to 500 cfm of outside air to be brought into the space without putting a large ventilation load on the unit ventilator system.

Cabinet Finish

The unit cabinetry is made of a durable industrial grade metal to withstand student contact. An appliance grade paint treatment increases the aesthetics of the equipment while making it long-lasting for typical classroom environments.

An interior pipe channel on the energy recovery unit ventilator allows the installer to easily connect the HVAC's unit ventilator piping with existing system piping.

Access

A single panel access design of the unit is easily removable, and provides complete access to the unit fan, wheel, filter, and controls.

Fan and Motor Assembly

Fans for the energy recovery unit ventilator are double-inlet, forward-curved centrifugal variety. They have a maximum speed of 1,050 rpm with permanent split capacitor motors. The fan housing is constructed of heavy gauge metal to help reduce air noise during operation. Wheel motors are single-speed, permanent split capacitor with overload protection. Each fan is equipped with a three speed switch for air balancing.

Ultra Low Leak Dampers

An ultra-low leak, blade type outside air damper is installed on every energy recovery unit ventilator system. This helps ensure low leakage of the outside air when the equipment is off. The unit is available with two separate damper assemblies.

The fresh air damper is a positive closure damper operated by a 24-volt, 3-point floating control motor. The exhaust air damper is a gravity relief type damper in order to help avoid over-pressurization of the classroom.

Defrost Controls: In most cases, Trane's ultra low leak dampers effectively protect against unwanted air infiltration and possible desiccant wheel frosting. Yet many buildings face outdoor air temperatures lower than 10°F while still requiring outdoor air. For this reason, the energy recovery unit ventilator may be equipped with a unique defrost control. Electric pre-heat is used to prevent frost from building up on the heat exchange wheel and other components.

Filters

Each unit comes equipped with two separate filters. Depending on usage, the outside air filters can either be 1 or 2-inches thick (disposable or pleated style). They are easily removed, thrown away and replaced. There is also a 1-inch thick throwaway filter for exhaust air.

Subbases

Subbases may be ordered to create the desired height of the equipment if mating up to an existing or retrofit application.

Controls

The unit may be controlled through the ZN520 controller, or through a 24V binary signal. All units are shipped from the factory fully assembled, and run-tested to assure that a quality product is delivered.

Features and Benefits

Energy Recovery Unit Ventilator

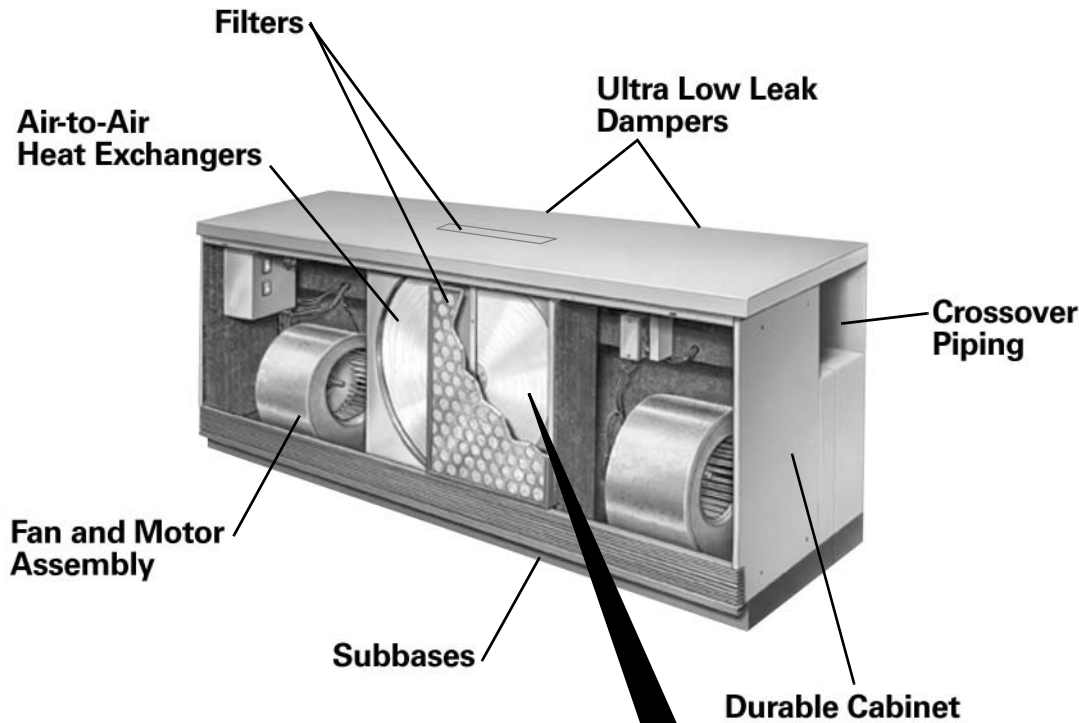

Air-to-Air Heat Exchanger

The air-to-air heat exchanger is designed to support two separate air streams in a counter-flow direction. The heat exchanger matrix prevents less than one percent of cross contamination between the air streams. The heat exchanger has the effectiveness of up to 80-percent with equal airflow. For extremely cold climates, it may be necessary to provide a means to prevent the wheel from frosting. The controls for the electric preheat are interlocked with a differential pressure switch to prevent the element from coming on without the fan operating. The electric preheat (frost prevention) kW should be sized based on the winter design dry bulb temperature and the frost threshold temperature. See selection procedure section to acquire the sizing equation.

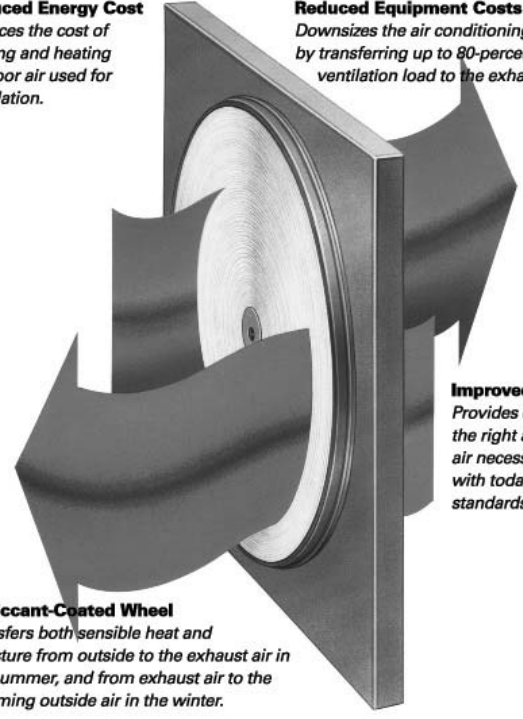

Reduced Energy Cost
Reduces the cost of cooling and heating outdoor air used for ventilation.

Reduced Equipment Costs
Downsizes the air conditioning capacity by transferring up to 80-percent of ventilation load to the exhaust air stream.

Improved Air Quality
Provides every room with the right amount of fresh air necessary to comply with today's IAQ standards like ASHRAE 62.

Desiccant-Coated Wheel
Transfers both sensible heat and moisture from outside to the exhaust air in the summer, and from exhaust air to the incoming outside air in the winter.

Features and Benefits

Shelving

Unit Ventilator Shelving

Trane's unit ventilator shelving was inspired by the needs of a classroom setting. The design supports applications from simple book or file storage to a draft barrier design. Piping compartments, a choice in tops and cut-to-fit fillers creates a custom approach to the space design. Trane's shelving is easy to install, and durable enough to withstand even the most rigorous classroom environment.

Cabinet Finish

The unit cabinetry is made of a durable industrial grade metal to withstand typical student wear/tear. An appliance grade paint treatment increases the aesthetics of the equipment while making it long-lasting.

All selections are equipped with leveling legs for proper matching to the classroom unit ventilator, energy recovery system or side wall exhaust system.

For units that include a dynamic (draft) barrier design, a floor spacer will be installed at the back of the shelving unit in order to block air flow under the unit.

Each shelving component ships from the factory with a standard set of installation hardware to help minimize the need for field supplied components.

The Formica® top option is available as a 1-inch particle board, finished with a choice of Formica laminate to compliment and coordinate with paint color of the shelving unit. The laminate is available in sections or continuous lengths for a seamless appearance. A flanged drop-in grille eliminates exposed edges, and is permanently fastened to prevent removal. The top may be ordered with or without a grille.

An attractive metal top, painted in the same color as the shelving unit, is a low cost option to flatter the classroom space.

Trane Unit Ventilator Shelving Configurations:

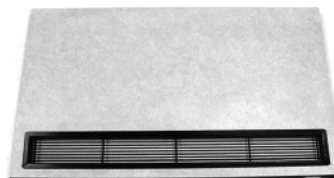

Closed Shelving

The closed shelving design is available in 2, 3, 4 and 5-foot lengths. Shelving depth includes 16 5/8" or 21 1/4" to accommodate retrofit and new equipment installations. The units are equipped with adjustable shelves that are reinforced with a formed channel for maximum strength. Closed shelving doors include two locks as standard. A bottom door guide adds stiffness and durability for the sliding doors.

Open Shelving

The open shelving design is available in 2, 3, 4 and 5-foot lengths. Shelving depth includes 16 5/8" or 21 1/4" to accommodate retrofit and new equipment installations. The units are equipped with adjustable shelves that are reinforced with a formed channel for maximum strength.

Cut-to-fit Filler

The cut-to-fit filler piece is designed to fill the gaps between small spaces. The filler is available in an 18" or 36" length, and may be cut-to-fit an area as small as 4-inches. The fill-in section has a removable front panel to allow access to piping or electrical connections.

Piping Compartment

The piping compartment is equipped with a metal top, leveling legs and a locking front panel. It is a standalone piece of equipment that is best suited for housing piping equipment for the unit ventilator. The compartment is designed to be attached to either end of the unit ventilator.

Formica Laminate Top

The laminate top selection is available in many decorative colors, and in lengths up to 12-feet. The tops may be cut in the field to match any specific length requested. A Gator Ply™ underside seals out moisture that could potentially cause warping. It is available with or without a grille.

Features and Benefits

Side Wall Power Exhaust

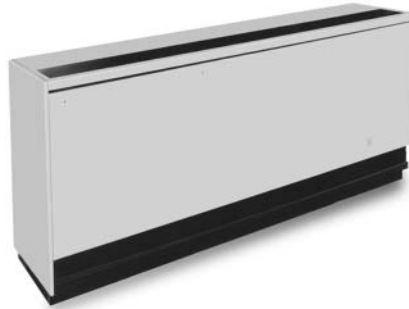

Side Wall Power Exhaust

Quick removal of concentrated air contaminants and building pressurization are two reasons to include an exhaust systems into the IAQ design. Building areas that often contain a build-up of these contaminants are science labs, vocational/technical shops, cafeterias, and indoor pools. These areas should be maintained under negative pressure relative to adjacent spaces.

Trane's side wall power exhaust system is designed to aid in the removal of these contaminants from the classroom environment. As a standalone unit design, the side wall power exhaust may be utilized with or without the complete unit ventilation system. Unit control may also be delivered through a ZN520 controller connection, allowing the side wall power exhaust to blend seamlessly with the vertical unit ventilator system to sustain complimentary unity of the entire classroom design.

Equipment Size

The side wall power exhaust provides a nominal 500 (single fan) or 750 (dual fan) cfm with a two speed switch. The unit is available in a 15 1/4", 16 1/4" or 21 1/4" depth to support all retrofit and new construction applications.

Cabinet Finish

The unit cabinetry is made of a durable industrial grade metal to withstand typical student wear/tear. An appliance grade paint treatment increases the aesthetics of the equipment while making it long-lasting. Adjustable leveling legs are designed into the base corners providing flexibility to mate the unit with the unit ventilator, shelving or the energy recovery system. The single front panel is secured by three camlock fasteners.

A polyurethane gasket seal is placed along the perimeter of the discharge opening to secure the back draft damper at the wall opening.

Motor and Drive

All motors are a two-speed, 115/60/1 voltage and fans are direct-drive. The motors are permanently lubricated, sleeve type bearings which do not require oiling.

Unit Switch

The unit's on-off switch is housed in the left hand end pocket below the discharge air grille.



Features and Benefits

Wall Boxes and Gravity Damper

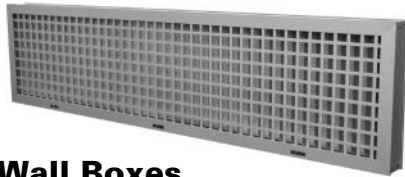

Wall Boxes

Wall boxes are to be installed prior to mounting the Classroom Unit Ventilator, Side Wall Exhaust, or Energy Recovery Unit Ventilator. Its intended use is to help deter animals, trash, or rain-fall from entering into the mechanical system providing a year-round outdoor intake for the HVAC equipment.

Finish

Trane's wall boxes are constructed of heavy gauge aluminum and designed to last the life of the building. Internal parts are interlocked, in addition to being held securely in place by the frame-within-a-frame design. This assures proper louver alignment.

Louvers are vertically or horizontally aligned, and held in position by an integral spacing guide. The boxes are available with an anodized aluminum finish, or a baked enamel finish.

Wall box arrangements are furnished with a diamond pattern, expanded aluminum bird screen to eliminate objects from blowing into the building. The grilles are aluminum and the same finish as the frame.

Wall Box Types

Trane offers a variety of wall boxes to support different needs and applications. Each are sized to match the classroom unit ventilator intake, and may be ordered with or without a recessing flange. See dimensional data for free area velocity of each wall box design.



Gravity Relief Damper

The gravity relief damper is a barometrically operated design which prevents over pressurization of the classroom. The damper is typically located in a plenum, or behind the 21 1/4" classroom shelving with a grilled top. An optional wall box is recommended to deter objects from easy entry into the building.

Finish

Trane's gravity relief damper is constructed from high grade aluminum and is designed for durability and long-stay. The dampers are horizontally arranged into the assembly.

Pipe Cover

The pipe cover assembly consists of the pipe enclosure, mounting strip and pipe hangers. It adds a decorative touch to the room decor by removing the supply/return/condensate pipe exposure.

The enclosure is constructed from heavy gauge metal and finished to match the classroom unit ventilator. The steel cover is locked to the mounting strip with non-visible fasteners. The mounting strip is a continuous roll formed steel and contains a full length channel for the enclosure. The pipe hangers are .148-inch in diameter, zinc plated steel wire. The hangers are designed to support up to two, 2 1/8" O.D. insulated pipes.

Application Considerations

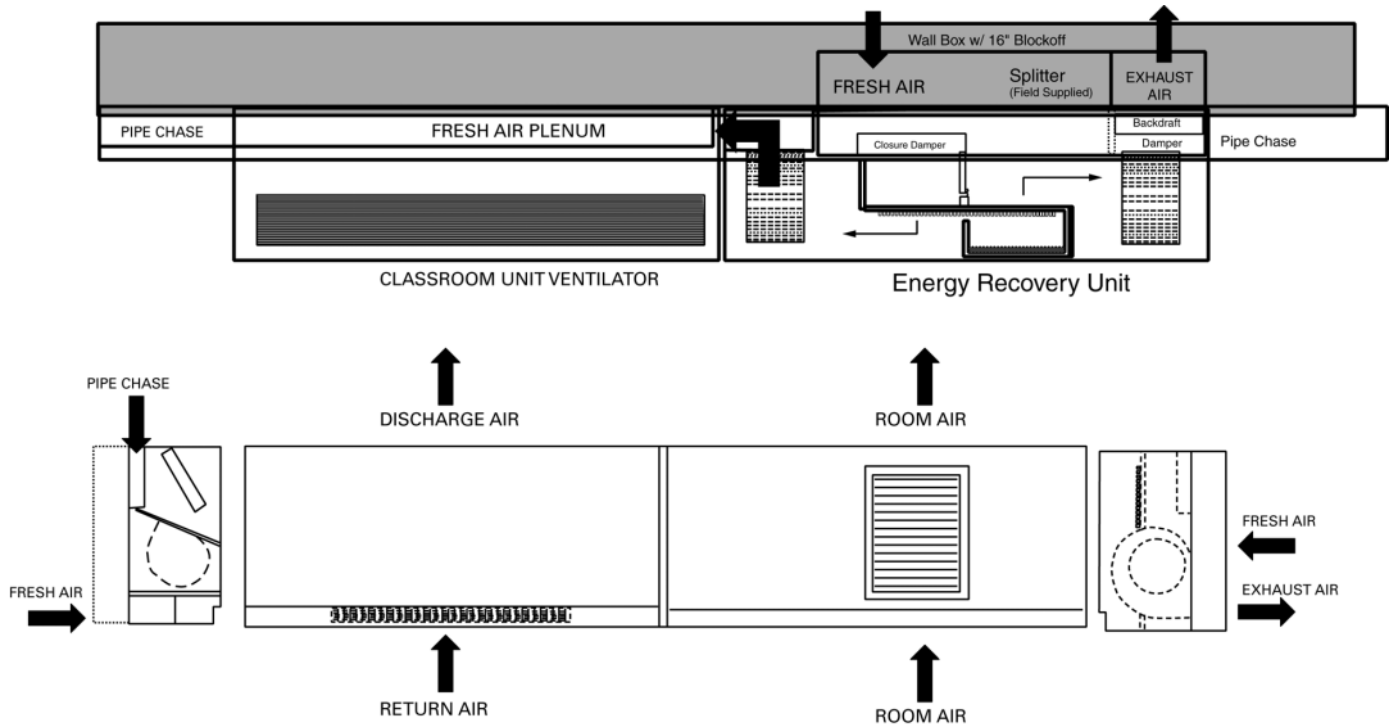

Energy Recovery Unit Ventilator Operation

An energy recovery ventilator can help make mechanical ventilation more cost effective by transferring energy between the outdoor air and the building exhaust air. This desiccant-coated wheel revolves through the outdoor and exhaust air streams. During the cooling season, sensible heat and moisture are transferred from the outdoor air to the exhaust air stream, and rejected from the building. During the heating season, sensible heat and moisture are transferred from the exhaust air to the outdoor air stream, heating and humidifying the entering outdoor air.

After passing through the energy recovery unit ventilator, the warmed or cooled fresh air goes through the classroom unit ventilator for further air treatment.

In extremely cold climates, it may be necessary to provide some means to prevent the wheel from frosting. Trane's energy recovery unit ventilator is equipped with a UL-listed electric resistance preheat element for frost prevention.

The controls for the electric preheat coil are interlocked with a differential pressure switch to prevent the element from coming on without the fan operating.

The electric preheat coil should be sized based on winter design dry bulb temperature (T_{OA}) and the frost threshold temperature (T_{TH}). Example:

$$\text{kW required} = \frac{1.08 \times 500 \text{ cfm} \times (T_{TH} - T_{OA})}{3134}$$

Where frost threshold is determined by the relative humidity of the space in the winter.

Room Relative Humidity	Frost Threshold Temp - T_{TH} (F)
30%	5
40%	10
50%	15



Model Number Shelving

SHL B G 2 05 D0 0 F A D 0 0 0
5 10 15

DIGIT 1-3: UNIT CONFIGURATION

SHL = Classroom Shelving

DIGIT 4: DEVELOPMENT SEQUENCE

B = Current Sequence

DIGIT 5: SHELVING STYLE

- 0 = Continuous Top ONLY/No Shelving
- 2 = 18-inch Cut-to-Fit Filler
- 3 = 36-inch Cut-to-Fit Filler
- 4 = 12-inch Piping Compartment
- 5 = 18-inch Piping Compartment
- A = 2-ft Open Shelving
- B = 3-ft Open Shelving
- C = 4-ft Open Shelving
- D = 5-ft Open Shelving
- E = 3-ft Closed Shelving
- F = 4-ft Closed Shelving
- G = 5-ft Closed Shelving
- H = 3-ft Open Shelving with Dynamic Air Barrier
- J = 4-ft Open Shelving with Dynamic Air Barrier
- K = 5-ft Open Shelving with Dynamic Air Barrier
- L = 3-ft Closed Shelving with Dynamic Air Barrier
- M = 4-ft Closed Shelving with Dynamic Air Barrier
- N = 5-ft Closed Shelving with Dynamic Air Barrier

DIGIT 6: SHELVING TOP DEPTH/GRILLE

- 0 = Not Required
- 1 = 16 5/8-inch Shelving and Top Depth
- 2 = 21 1/4-inch Top Depth w/o Grille
- 3 = 21 1/4-inch Top Depth w/ Steel Grille
- 4 = 21 1/4-inch Top Depth w/Aluminum Grille and Damper
- 5 = 21 1/4-inch Top Depth w/Aluminum Grille
- 6 = 16 5/8-inch Deep Piping Compartment
- 7 = 21 1/4-inch Deep Piping Compartment

DIGIT 7&8: LENGTH of FORMICA TOP

- 00 = No Formica Top for Shelving Selected
- 01 = Formica Top w/Same Size and Shelving
- 02 = 2-ft Top Only (no shelving)
- 03 = 3-ft Top Only (no shelving)
- 04 = 4-ft Top Only (no shelving)
- 05 = 5-ft Top Only (no shelving)
- 06 = 6-ft Continuous Top
- 07 = 7-ft Continuous Top
- 08 = 8-ft Continuous Top
- 09 = 9-ft Continuous Top
- 10 = 10-ft Continuous Top
- 11 = 11-ft Continuous Top
- 12 = 12-ft Continuous Top
- 18 = 18-inch Top Only (no shelving)

DIGIT 9&10: DESIGN SEQUENCE

Current Sequence

DIGIT 11: DECORATOR FORMICA TOPS

- 0 = No Top
- 1 = Metal Top
- A = Champagne Papyrus Formica® Top
- E = Almond Formica Top
- F = Ivory Blushing Formica Top
- G = Natural Canvas Formica Top
- H = Glacier Slate Formica Top
- J = Birch Formica Top
- K = Folkstone Formica Top
- M = Fog Formica Top
- N = Tundra Terra Formica Top
- Q = Stone Dust Formica Top

DIGIT 12: SHELVING PAINT COLOR

- 0 = No Color Shelving Finish
- A = Cameo White Shelving Finish
- B = Soft Dove Shelving Finish
- C = Deluxe Beige Shelving Finish
- D = Driftwood Grey Shelving Finish
- E = Rose Mauve Shelving Finish
- F = Stone Grey Shelving Finish
- G = Bronze Tone Shelving Finish

DIGIT 13: END COVERS

- 0 = No End Covers
- A = 16 5/8-inch Deep End Covers w/o Cutouts
- B = 16 5/8-inch Deep End Covers w/Std. Cutouts
- C = 16 5/8-inch Deep End Covers w/Extended Cutouts
- D = 21 1/4-inch Deep End Covers w/o Cutouts
- E = 21 1/4-inch Deep End Covers w/Std. Cutout
- F = 21 1/4-inch Deep End Covers w/Extended Cutouts

DIGIT 14: SUBBASE

- 0 = No Subbase Feature
- 2 = 2-inch Subbase
- 4 = 4-inch Subbase
- 6 = 6-inch Subbase

DIGIT 15: KICKPLATE

- 0 = Louver Front Kickplate (no side)
- 1 = Louver Front and Side Kickplate
- 2 = Solid Front Kickplate (no side)
- 3 = Solid Front and Side Kickplate

DIGIT 16: KEY LOCK

- 0 = Standard Lock
- 1 = Master Key for Lock

ADDITIONAL ACCESSORIES

SGRL: Extra Steel Grille

- 2ft: Extra 2-ft Steel Grille
- 3ft: Extra 3-ft Steel Grille
- 4ft: Extra 4-ft Steel Grille
- 5ft: Extra 5-ft Steel Grille

AGRL: Extra Aluminum Grille

- 2ft: Extra 2-ft Aluminum Grille
- 3ft: Extra 3-ft Aluminum Grille
- 4ft: Extra 4-ft Aluminum Grille
- 5ft: Extra 5-ft Aluminum Grille



Model Number

Energy Recover Unit Ventilator

ERS A 050 2 0 A0 0 A 1 2 1 0 0 CA
5 10 15 20

DIGIT 1-3: UNIT CONFIGURATION
ERS = Energy Recovery System

DIGIT 4: DEVELOPMENT SEQUENCE
A = First Generation

DIGIT 5-7: NOMINAL CAPACITY
050 = 500 CFM

DIGIT 8: UNIT INCOMING POWER SUPPLY
1 = 120V/1-Phase Power Supply
2 = 208V/1-Phase Power Supply
3 = 240V/1-Phase Power Supply
4 = 277V/1-Phase Power Supply

DIGIT 9: ETL LISTING
0 = No ETL Listing
1 = ETL Listing

DIGIT 10&11: DESIGN SEQUENCE
Current Design

DIGIT 12: ELECTRIC DEFROST
0 = None
2 = 1.00 kW 208V/1-Phase
3 = 2.00 kW 208V/1-Phase
4 = 2.44 kW 208V/1-Phase
5 = 1.07 kW 240V/1-Phase
6 = 2.00 kW 240V/1-Phase
7 = 3.25 kW 240V/1-Phase
8 = 1.42 kW 277V/1-Phase
9 = 2.73 kW 277V/1-Phase
A = 3.25 kW 277V/1-Phase

DIGIT 13: SUPPLY-AIR INLET to UNIT VENT
A = LH Inlet to UV (4-Pipe, Pipe Chase)
B = RH Inlet to UV (4-Pipe, Pipe Chase)
C = LH Inlet to UV (2-Pipe, Pipe Chase)
D = RH Inlet to UV (2-Pipe, Pipe Chase)

DIGIT 14: DAMPER CONFIGURATION
0 = No Damper
1 = Backdraft Damper on Exhaust
2 = Shut-Off Damper on Supply
3 = Backdraft Damper on Exhaust & Shut-Off Damper on Supply

DIGIT 15: Controls
1 = Field Supplied/End Device
2 = Field Supplied w/Economizer
3 = Tracer™ ZN520 Controls

DIGIT 16: SUPPLY-AIR FILTER SIZE
2 = 1-inch Pleated Media (Std.)

DIGIT 17: COLOR SELECTION
1 = Deluxe Beige
2 = Cameo White
3 = Soft Dove
4 = Stone Grey
5 = Driftwood Grey

DIGIT 18: END COVER
0 = No End Cover

DIGIT 19: SUBBASE
0 = No Unit Subbase
A = 2-inch Subbase
B = 4-inch Subbase
C = 6-inch Subbase

DIGIT 20: OPEN DIGIT
0 = Open Digit

DIGIT 21: WALL BOX and WALL BOX FINISH
00 = No Wallbox
CA = Clear Anodized Finish
LB = Light Bronze Finish
MB = Medium Bronze Finish
DB = Dark Bronze Finish
B1 = Brick (BR1) Finish
B3 = Brick (BR3) Finish
B5 = Brick (BR5) Finish
WH = White Finish
BL = Black Finish



Model Number

Side Wall Exhaust/Gravity Damper

SWE A 050 **1** 0 E0 **V1** LB **A** **1** **0** **1** **0** **1**

5 10 15

DIGIT 1-3: UNIT CONFIGURATION

SWE = Side Wall Exhaust
SWG = Gravity Relief Damper

DIGIT 4: DEVELOPMENT SEQUENCE

A = Current Sequence

DIGIT 5: UNIT SIZE

CAB = Cabinet Only
050 = 500 CFM (SWE-SWG)
075 = 750 CFM (SWE-SWG)
100 = 1000 CFM (SWG only)
125 = 1250 CFM (SWG only)
150 = 1500 CFM (SWG only)
200 = 2000 CFM (SWG only)

DIGIT 8: UNIT VOLTAGE/PHASE

0 = Not Required for SWG or CAB
1 = 120V/1 PH Power

DIGIT 9: AGENCY LISTING

0 = No Listing
2 = ETL Agency Listed

DIGIT 10-11: DESIGN SEQUENCE

E0 = Current Sequence

DIGIT 12-13: WALL BOXES

00 = Wall Box Not Required
V1 = Wall Box w/ Vertical Louvers
V2 = Wall Box w/ Vertical Louvers and Flush Lattice
V3 = Wall Box w/ Vertical Louvers and Side Flange
V6 = Wall Box w/ Vertical Louvers, Flange and Lattice
H1 = Wall Box w/ Horizontal Louvers
H2 = Wall Box w/ Horizontal Louvers

DIGIT 14-15: WALL BOX FINISH

00 = No Wall Box
CA = Clear Anodized
LB = Light Bronze
MB = Medium Bronze
DB = Dark Bronze
B1 = Brick, Option 1
B3 = Brick, Option 2
B5 = Brick, Option 5
WH = White
BL = Black

DIGIT 16: UNIT DEPTH

0 = SWG
A = 15 1/4" Standard Depth
B = 16 1/4" Extended Depth
F = 21 1/4" False Back

DIGIT 17: FRONT PANEL

0 = SWG
1 = Standard Grade Panel
2 = Industrial Grade Panel

DIGIT 18: END COVER

0 = No End Cover
A = 15 1/4-inch Deep End Covers w/o Cutouts
B = 15 1/4-inch Deep End Covers w/Std. Cutouts
C = 15 1/4-inch Deep End Covers w/Extended Cutouts
D = 21 1/4-inch Deep End Covers w/o Cutouts
E = 21 1/4-inch Deep End Covers w/Std. Cutout
F = 21 1/4-inch Deep End Covers w/Extended Cutouts

DIGIT 19: COLOR SELECTION

0 = SWG
1 = Deluxe Beige
2 = Cameo White
3 = Soft Dove
4 = Stone Gray
5 = Driftwood Gray

DIGIT 20: SUBBASE SELECTION

0 = No Unit Subbase
A = 2" Subbase
B = 4" Subbase
C = 6" Subbase

DIGIT 21: CONTROLS

0 = SWG or CAB
1 = Manual 2-Speed Switch



General Data

Table 1: Energy Recovery Unit Ventilator (ERS)

Unit Size	Efficiency Range	Dimensions L x W x H	Weight		Electrical		
			with Skid	without Skid			
500 CFM	75-80%	69" x 21 1/4" x 30"	331 lbs.	328 lbs.	120V-60HZ-1PH	208/230V-60HZ-1PH	277V-60HZ-1PH

ERS filter sizing includes: Front panel exhaust = 14" x 20" x 1", and rear supply = 14" x 25" x 1"

Table 2: Side Wall Exhaust

Unit Size	Dimensions L x W x H	Weight		Electrical	Motor Type	No. of Fans
		with Skid	without Skid			
500 CFM	42" x 15 1/4" x 30"	275	250	115V-60HZ-1 PH 2.5 FLA 1050 RPM .17 HP	2-Speed Switch	1
	42" x 16 1/4" x 30"					
	42" x 21 1/4" x 30"					
750 CFM	42" x 15 1/4" x 30"	275	250	115V-60HZ-1 PH 2.5 FLA 1050 RPM .17 HP	2-Speed Switch	2
	42" x 16 1/4" x 30"					
	42" x 21 1/4" x 30"					



Electrical Data

Table E1: ERS-Unit Electrical Data without Electric Defrost

Supply Voltage	Minimum Circuit Ampacity	Fuse Size (Amps)
115	5.73	15
208/230	3.17	15
277	2.38	15

Table E2: ERS-Unit Electrical Data with Electric Defrost

Element kW	Supply Voltage	Minimum Circuit Ampacity	Fuse Size (Amps)
1	208/230	4.81	15
2.45	208/230	11.79	15
3.25	208/230	15.63	20
1.3	277	4.69	15
2.45	277	8.84	15
3.25	277	11.73	15

Table E3: ERS-Airflow

Voltage	Motor HP	Fan Speed (cfm) Low / Med / High	RPM Low / Med / High
120V-60HZ-1PH 208/230V-60HZ-1PH 277V-60HZ-1Ph	.25	350 / 390 / 490	735/850/1100

Table E4: SWE-Electrical

Voltage	Motor HP	Full Load Amps	RPM
115V-60HZ-1PH	.17	2.5	1050

Control Wiring

Energy Recovery System

Each energy recovery unit ventilator has a power relay in the control box controlling the unit through the Tracer™ ZN520 microprocessor control board. This board performs the following strategies:

Occupied Mode: The unit receives an energized signal from the ZN520 board to power the energy recovery unit. The outside air damper will open to 100% while starting the fans and the heat exchange wheel.

Fan Operation: The ventilation and exhaust fans operate at high speed in the occupied mode unless the unit is adjusted otherwise. The fan is manually adjusted to different speeds. If the unit ventilator goes unoccupied, the energy recovery ventilator's fan will turn off and the outside air damper will close. The controller will monitor the use of the energy recovery ventilator if a building automation system is installed.

Unoccupied Operation: In unoccupied mode, the outside air damper will remain closed, and the fan and wheel will remain off. The controller will change to unoccupied operation when commanded or programmed.

Economizer Control: When the unit is provided with economizer controls, the wheel is disabled during the economizer cycle.

Frost Prevention Control: Units may require electric preheat for frost prevention during extreme cold outdoor conditions. When equipped with electric preheat for frost prevention, the unit will house a defrost thermostat. The thermostat should be set to slightly above the frost threshold temperature, see page 9, to eliminate chances for frost build-up on the heat recovery wheel.

Morning Warm-up/Cool Down: When a warm-up/cool-down is initiated, the fan will remain off, and the outside air damper will remain closed. When the space temperature is within 3°F of the set point, the controller will automatically switch to occupied mode.

Control Wiring

ERS - With Electric Defrost

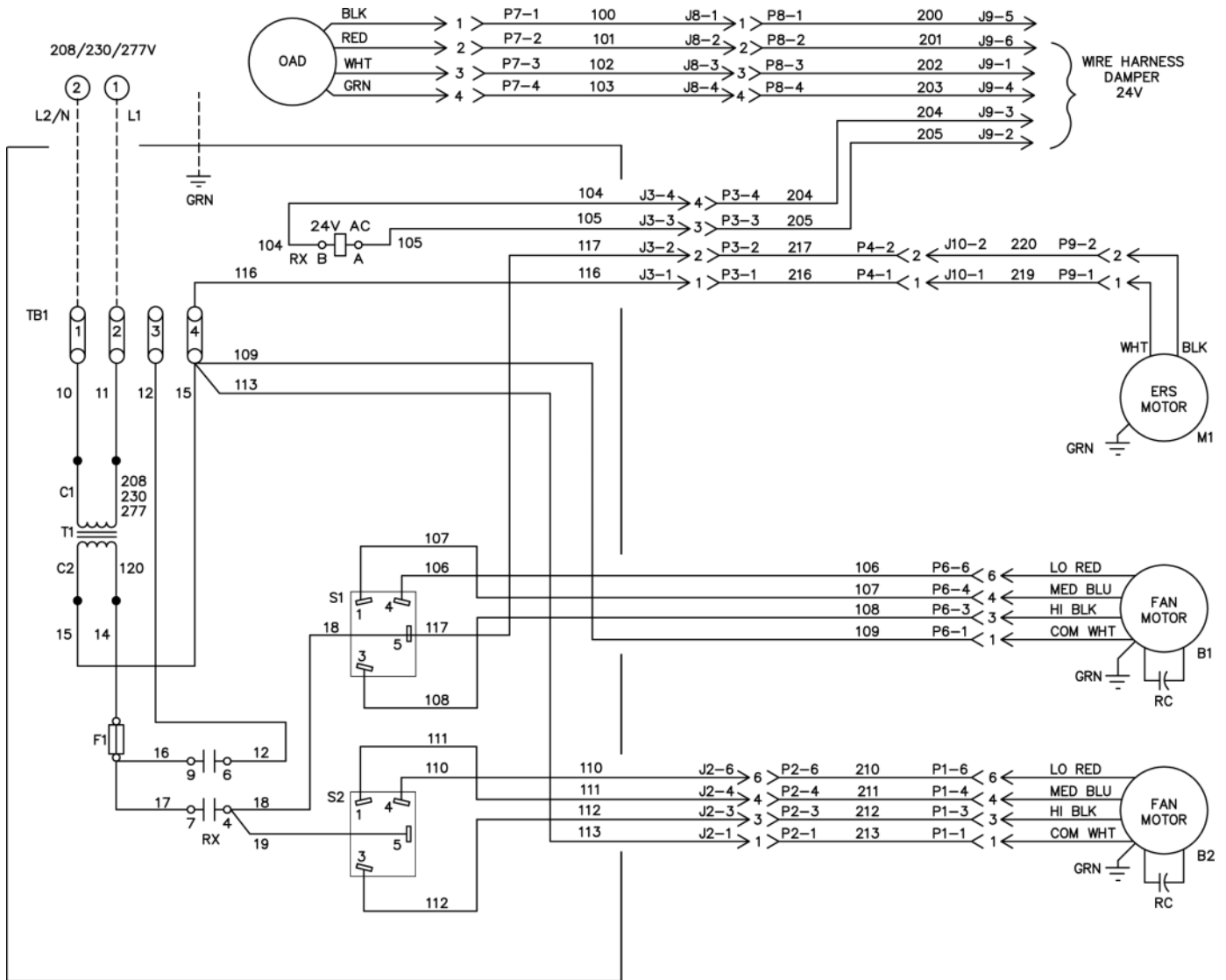

NOTE: TB1-3 IS USED FOR ELECTRIC HEAT & FAN INTERLOCK

B1	BLOWER MOTOR LH
B2	BLOWER MOTOR RH
F1	FUSE
M1	HEAT WHEEL MOTOR
RX	RELAY
S1	FAN SPEED SWITCH
S2	FAN SPEED SWITCH
OAD	OUTSIDE AIR DAMPER
RC	RUN CAPACITOR

WARNING

DISCONNECT ELECTRIC POWER SUPPLY BEFORE SERVICING TO PREVENT INJURY OR DEATH DUE TO ELECTRICAL SHOCK.

CAUTION

USE COPPER CONDUCTORS ONLY TO PREVENT EQUIPMENT DAMAGE. UNIT TERMINALS ARE NOT DESIGNED TO ACCEPT ANY OTHER WIRING.

Control Wiring

ERS - Without Electric Defrost

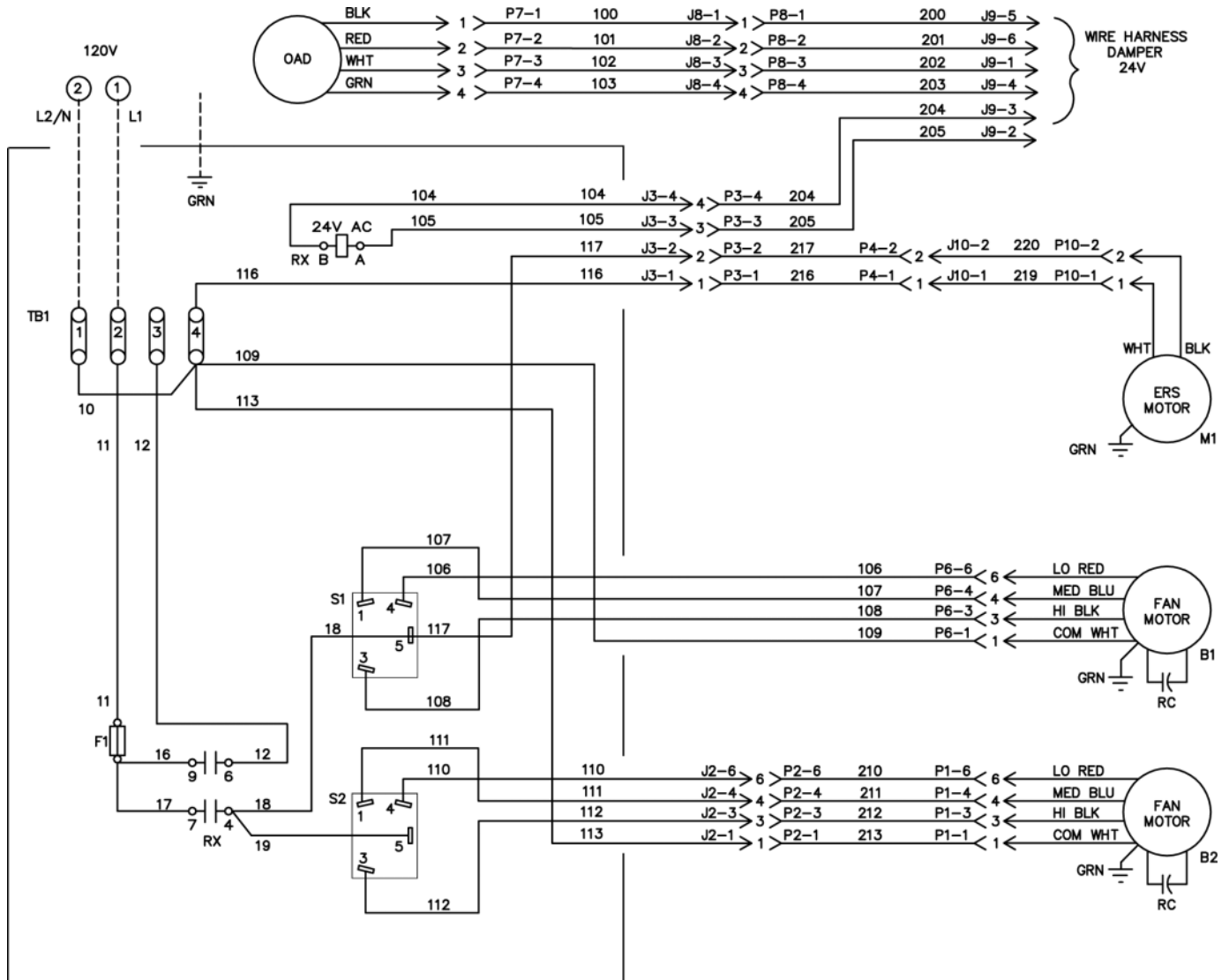

NOTE: TB1-3 IS USED FOR ELECTRIC HEAT & FAN INTERLOCK

B1	BLOWER MOTOR LH
B2	BLOWER MOTOR RH
F1	FUSE
M1	HEAT WHEEL MOTOR
RX	RELAY
S1	FAN SPEED SWITCH
S2	FAN SPEED SWITCH
OAD	OUTSIDE AIR DAMPER
RC	RUN CAPACITOR

⚠ WARNING
DISCONNECT ELECTRIC POWER SUPPLY BEFORE SERVICING TO PREVENT INJURY OR DEATH DUE TO ELECTRICAL SHOCK.

⚠ CAUTION
USE COPPER CONDUCTORS ONLY TO PREVENT EQUIPMENT DAMAGE. UNIT TERMINALS ARE NOT DESIGNED TO ACCEPT ANY OTHER WIRING.

Control Wiring

Side Wall Exhaust

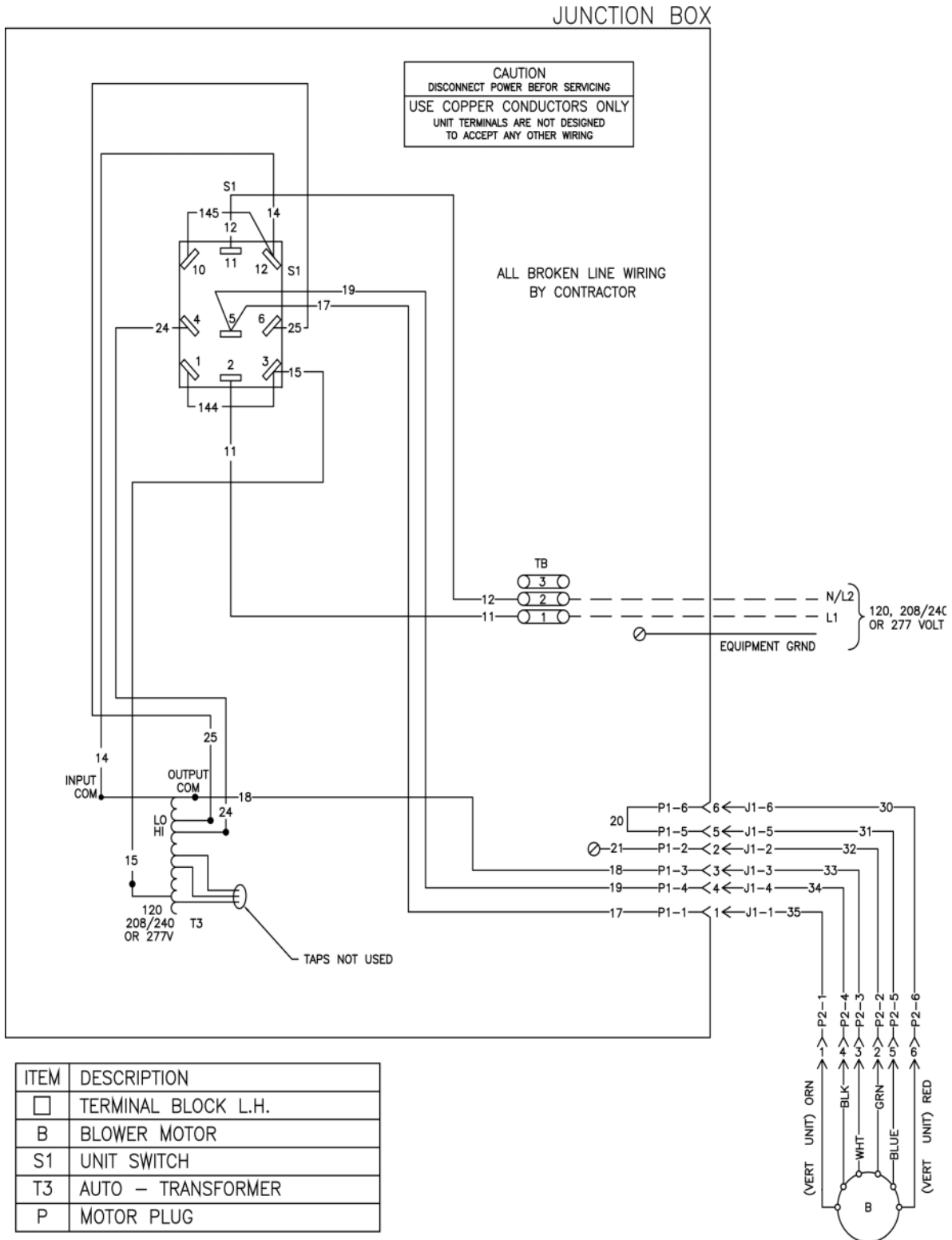

Dimensional Data

Energy Recovery Ventilator

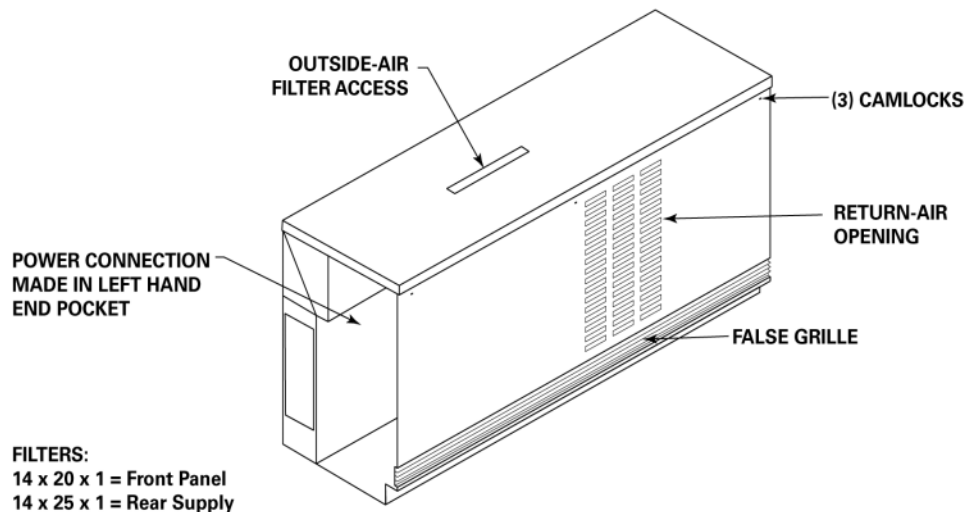
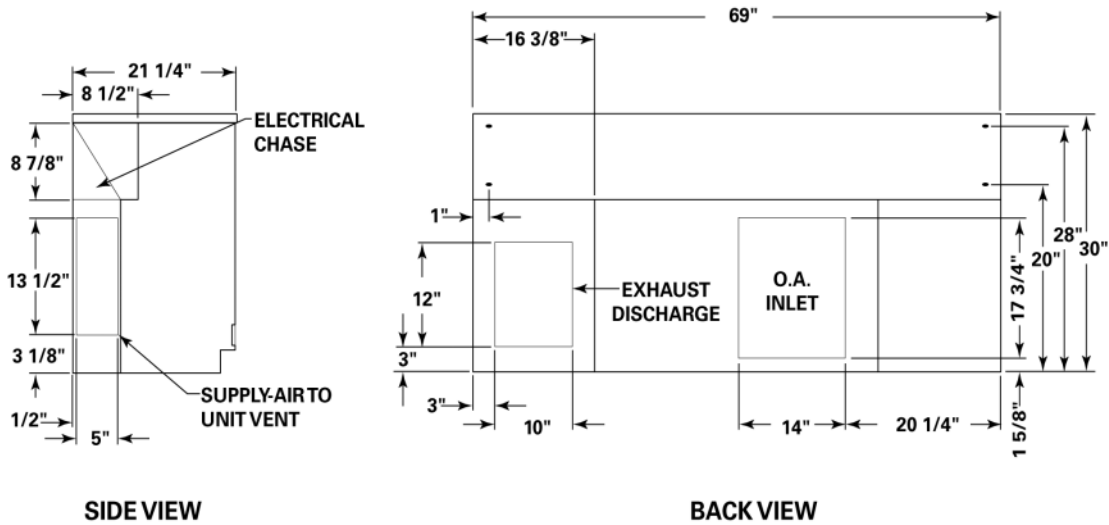

NOTE:

UNIT LENGTH DOES NOT INCLUDE END COVERS.

ADD 5/8" ON ONE SIDE FOR THE END PANEL.
 Only one needed.

ELECTRICAL CONNECTIONS TO THE VERTICAL UNIT VENTILATOR CAN BE MADE ON EITHER THE LEFT OR RIGHT SIDE OF THE UNIT.

Dimensional Data

Wall Box for ERS

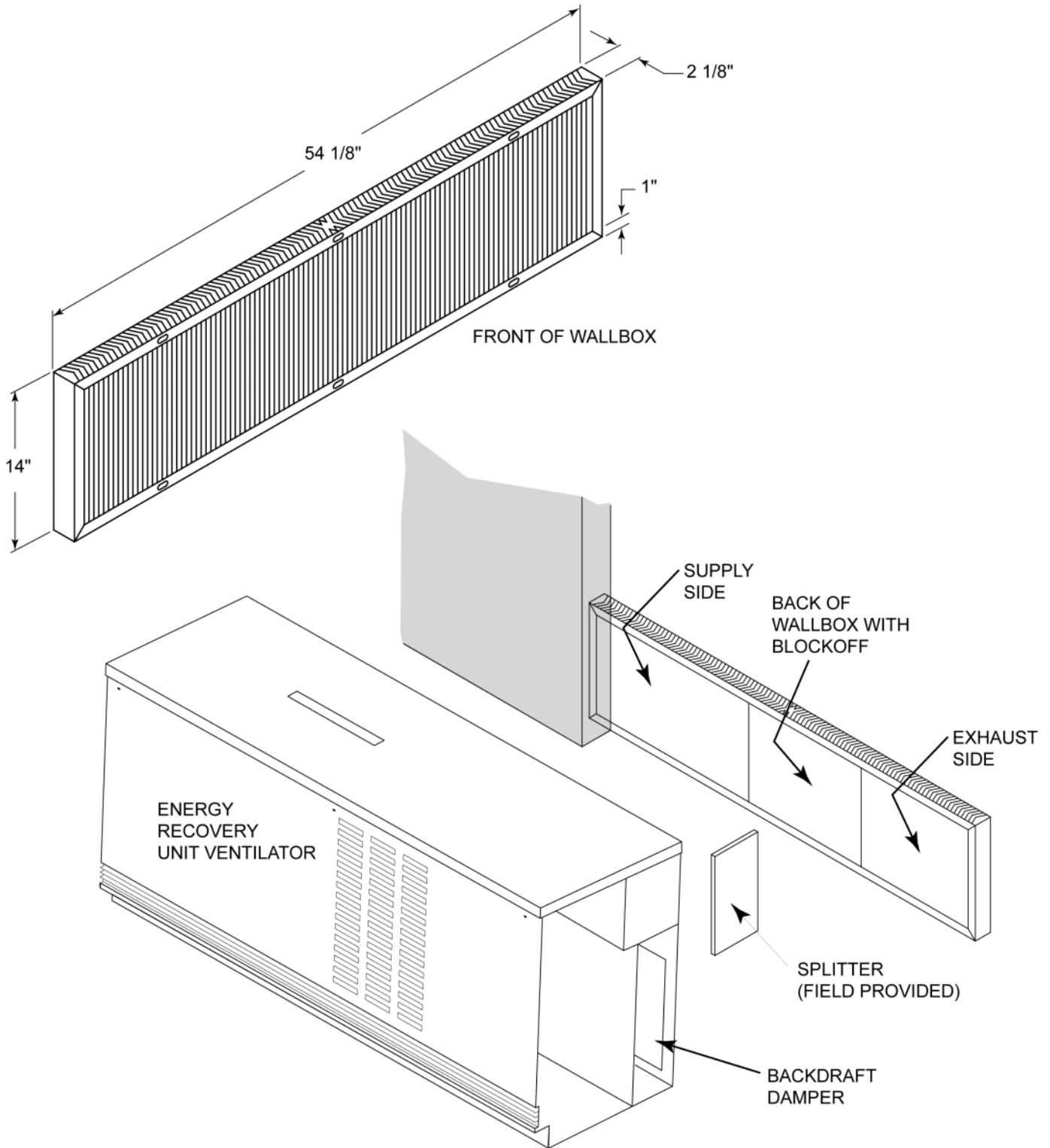

Dimensional Data

Side Wall Exhaust

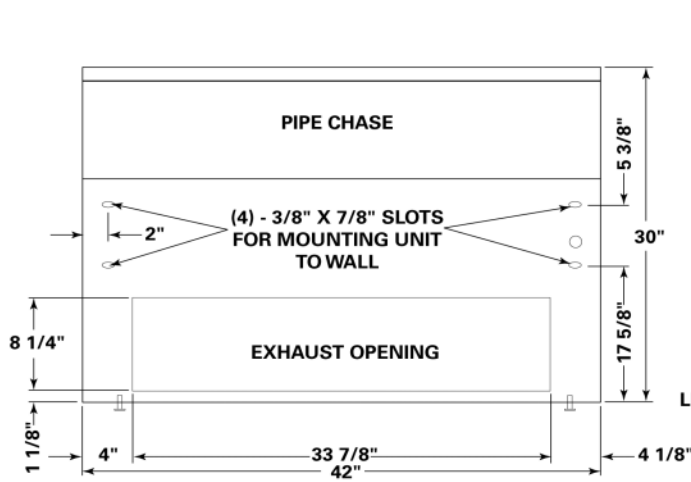

BACK VIEW

NOTE:
ADD 5/8" FOR EACH END PANEL.

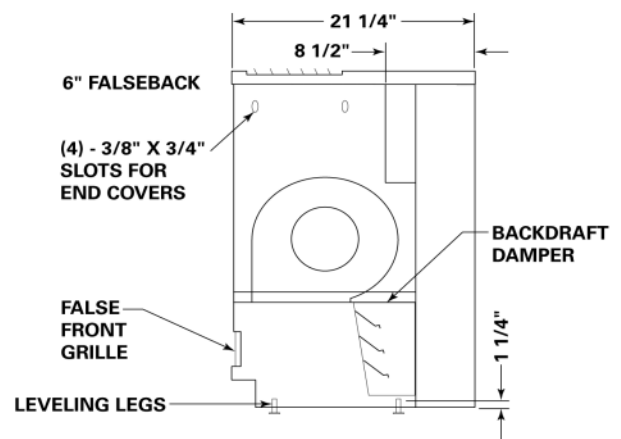
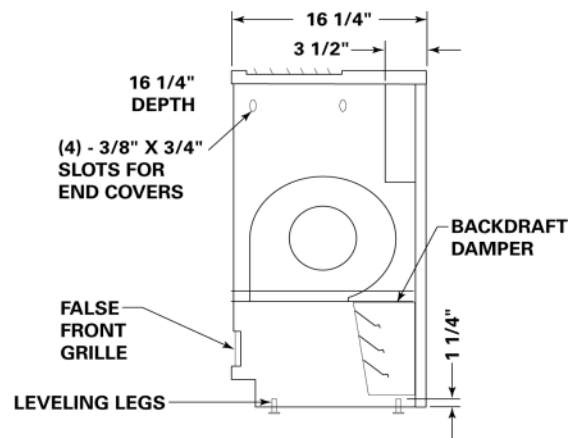
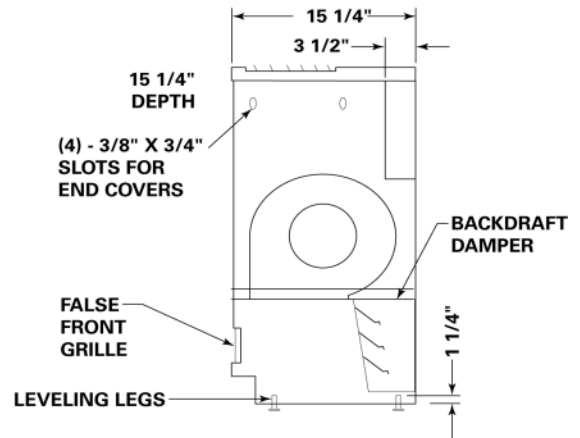
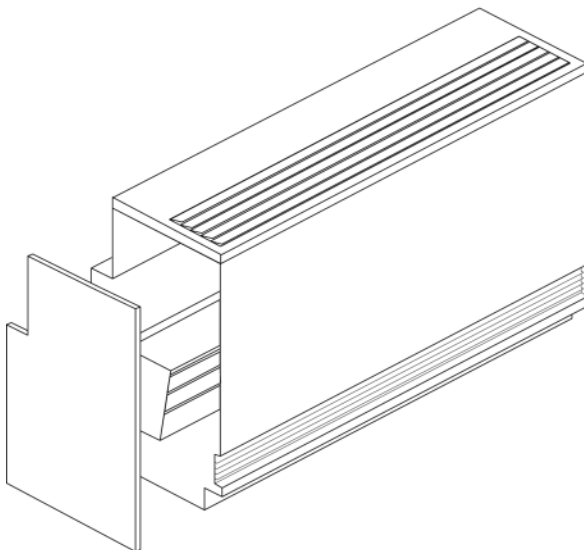

Dimensional Data

Gravity Relief Damper

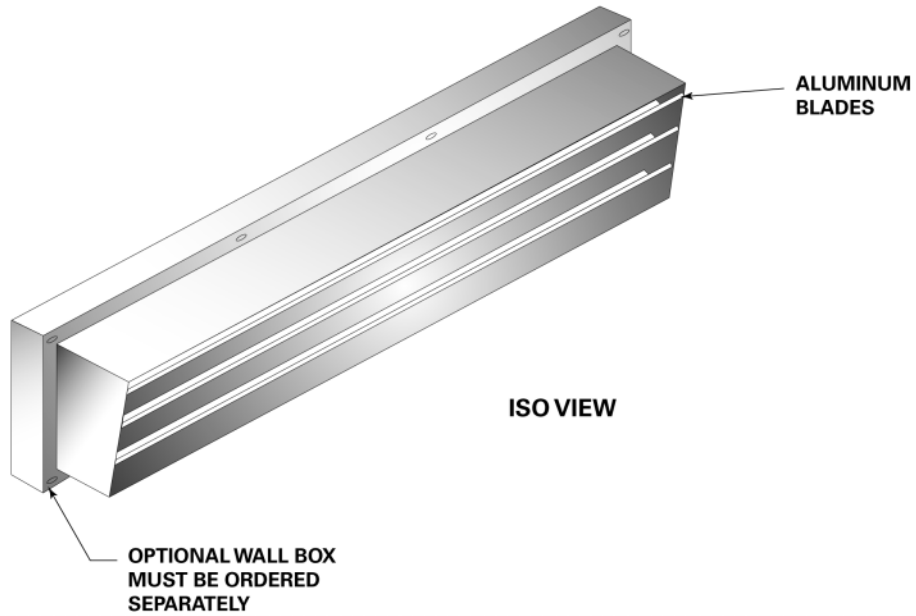
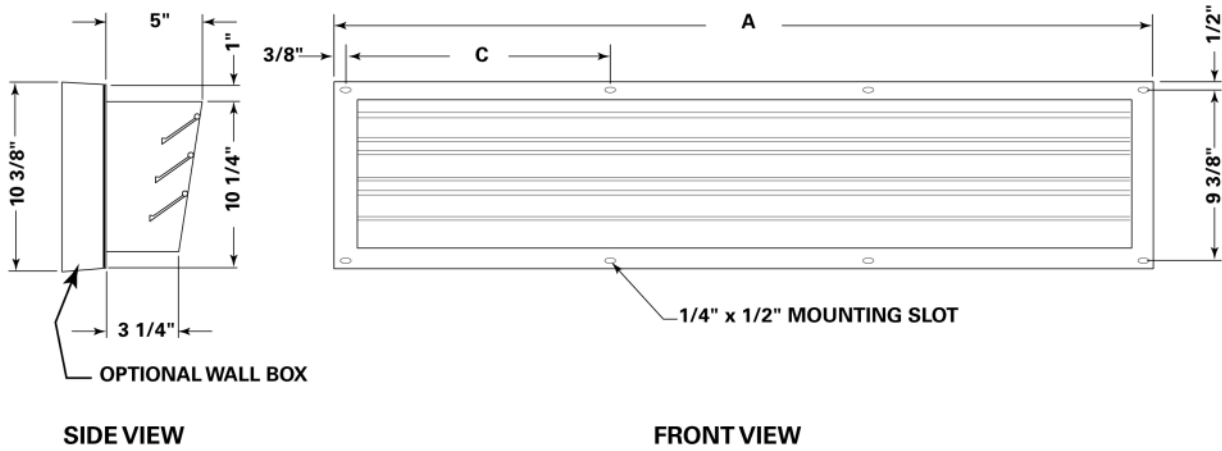

Dimensional Data

Shelving, Open or Closed

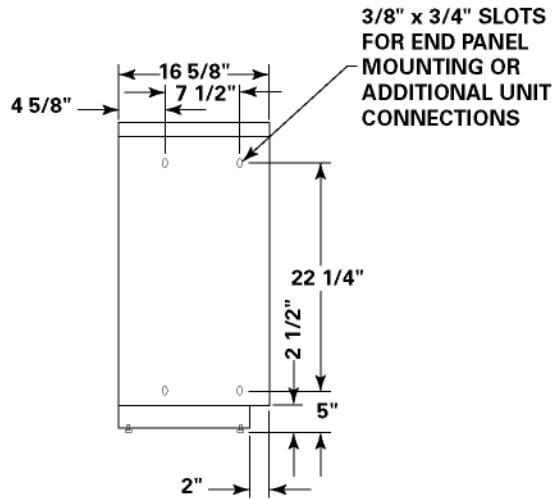

SIDE VIEW

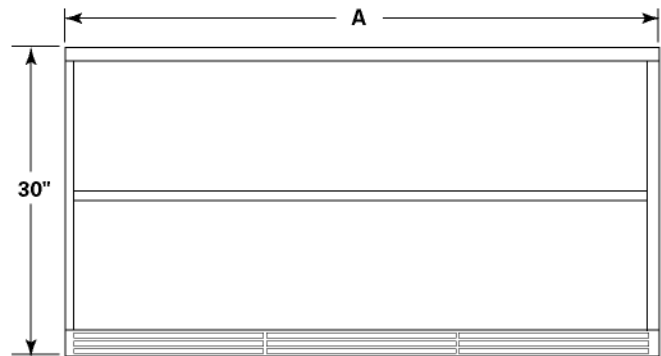

FRONT VIEW

NOTE: ADD 5/8" TO THE LENGTH FOR EACH END PANEL.

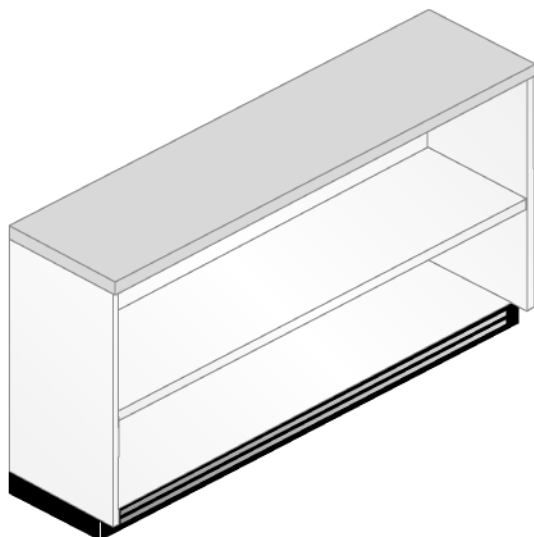

OPEN SHELVING

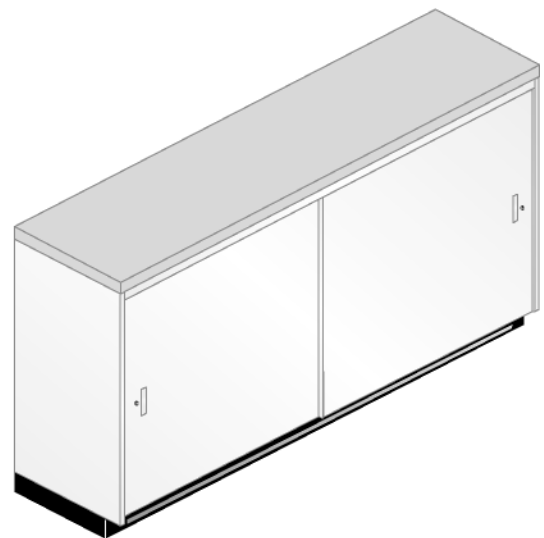

CLOSED SHELVING

Dimensional Data

Shelving with Dynamic Barrier

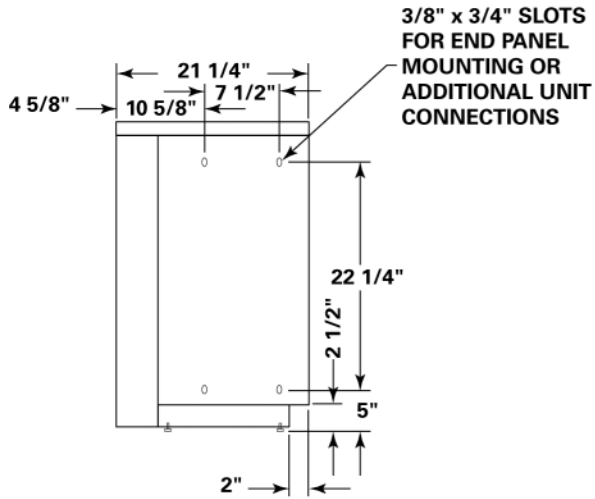

SIDE VIEW

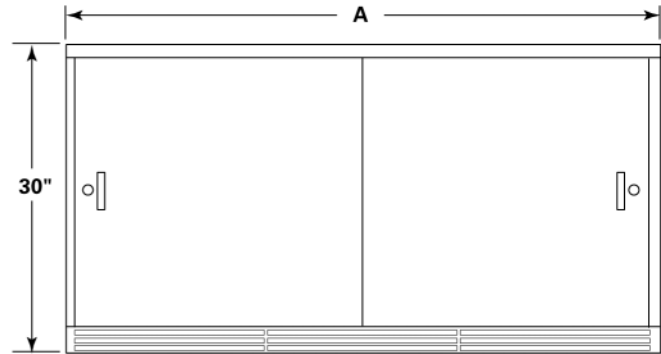

FRONT VIEW

NOTE:

A MANUAL DAMPER IS AVAILABLE WHEN ORDERING SHELVING WITH A GRILLE.

THE OPTIONAL GRILLE IS USED WITH WALL FIN OR IN A DYNAMIC AIR (DRAFT) BARRIER APPLICATION

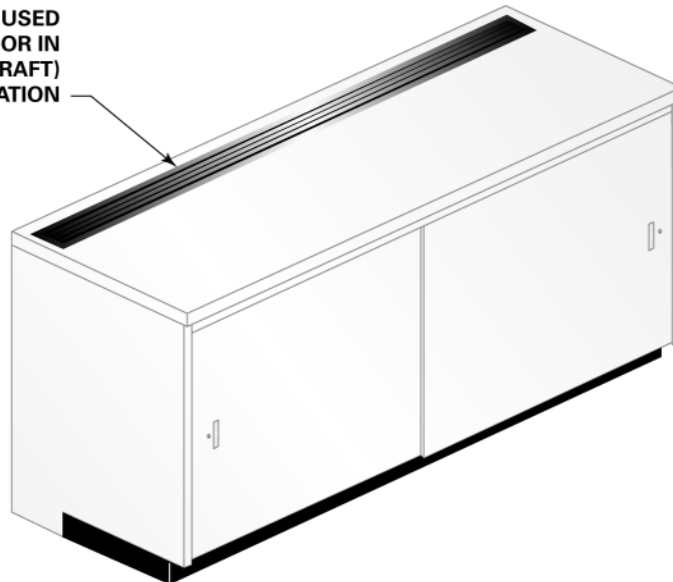

Dimensional Data

Shelving, Cut-to-Fit Filler

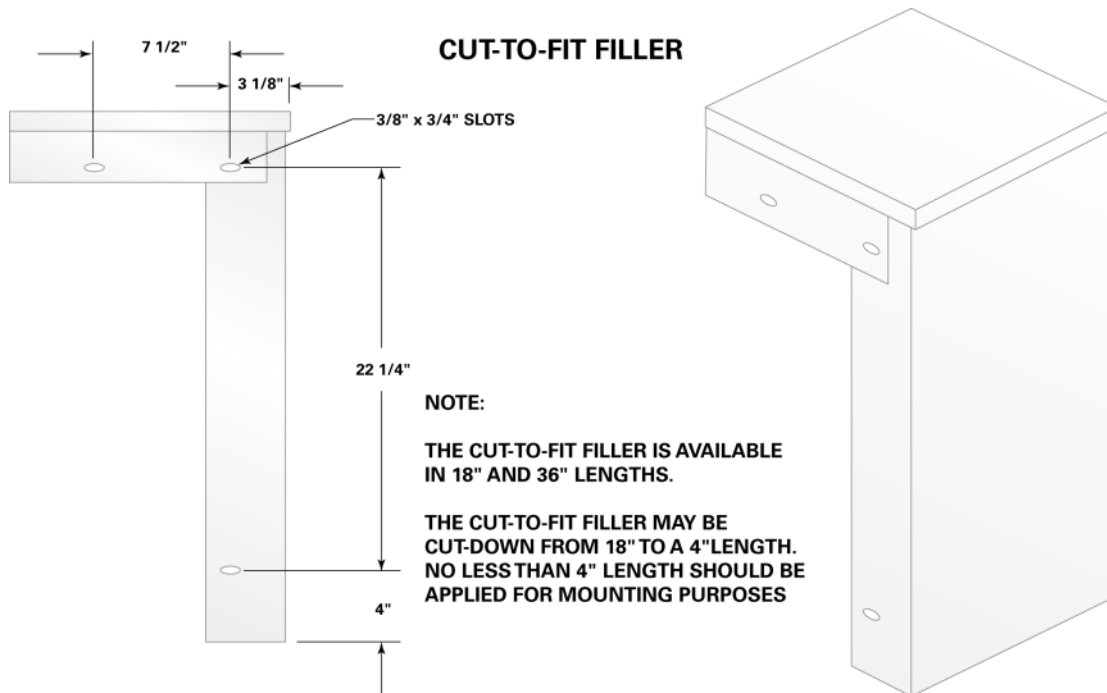

Dimensional Data

Pipe Cover

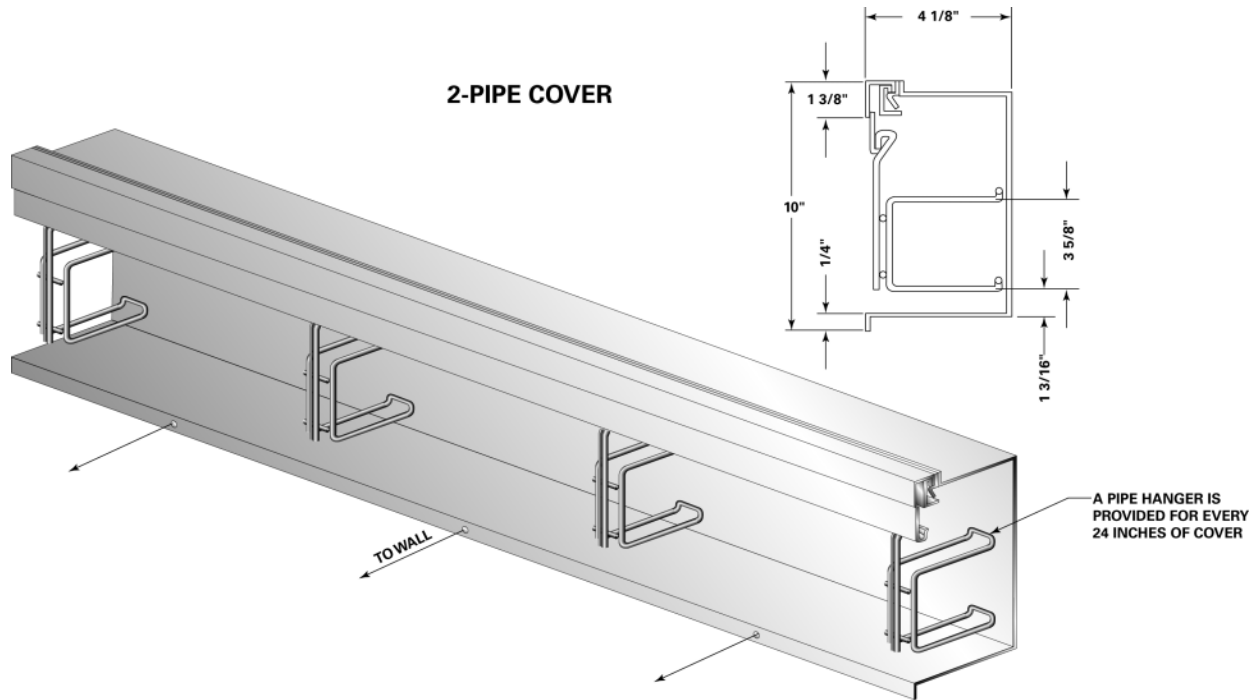

Dimensional Data

Wall Box, Horizontal Louver

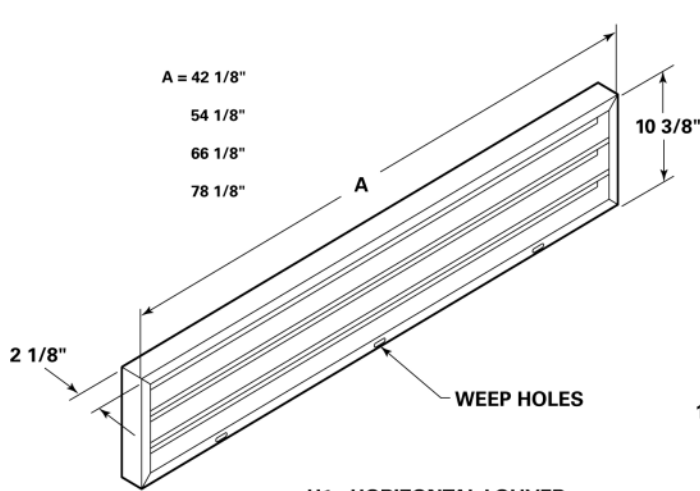

H1 - HORIZONTAL LOUVER

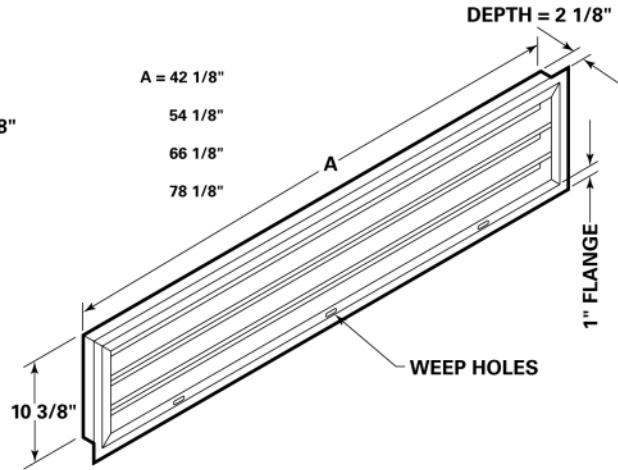

**H2 - HORIZONTAL LOUVER
with 1-inch recessing flange**

Unit Size	A	Square Feet of Free Area
075	42 1/8"	.81
100	54 1/8"	1.10
125	66 1/8"	1.39
150/200	78 1/8"	1.69

NOTE:
THE DIMENSIONS LISTED ABOVE ARE ACTUAL (NOT NOMINAL) DIMENSIONS.

THE HORIZONTAL BLADES OF THE H1 AND H2 WALL BOXES ARE SPACED 2" APART.

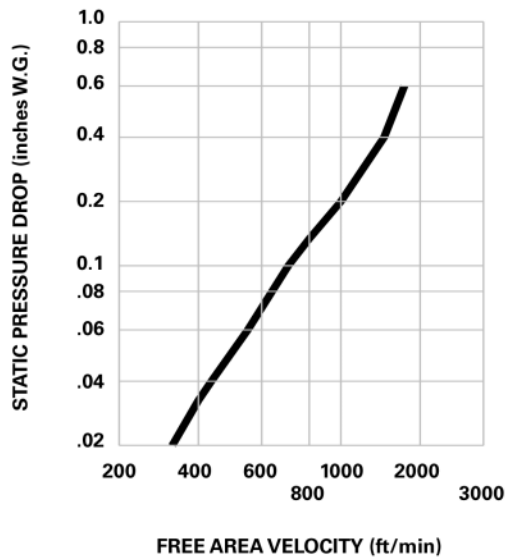

Dimensional Data

Wall Box, Vertical Louver

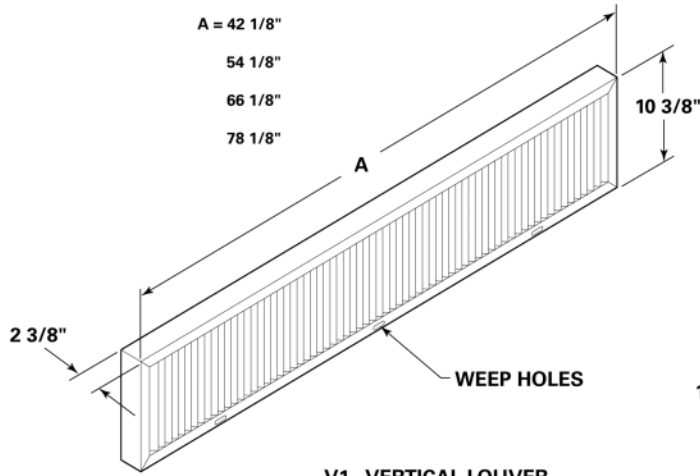

V1 - VERTICAL LOUVER

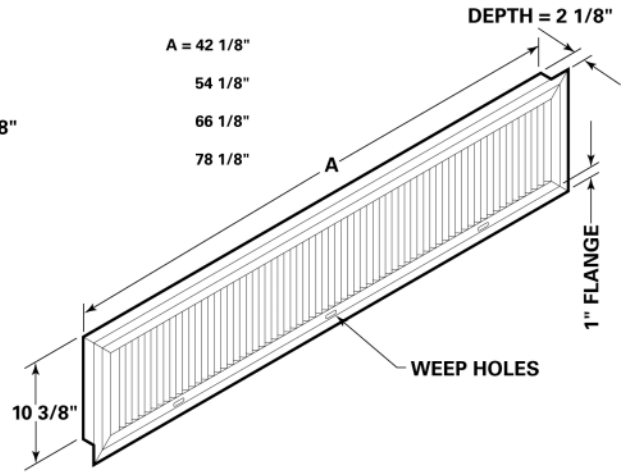

V3 - VERTICAL LOUVER
with 1-inch recessing flange

Unit Size	A	Square Feet of Free Area
075	42 1/8"	1.39
100	54 1/8"	1.88
125	66 1/8"	2.37
150/200	78 1/8"	2.87

NOTE:

THE DIMENSIONS LISTED ABOVE ARE ACTUAL (NOT NOMINAL) DIMENSIONS.

THE VERTICAL BLADES OF THE V1 AND V3 WALL BOXES ARE SPACED 3/8" APART.

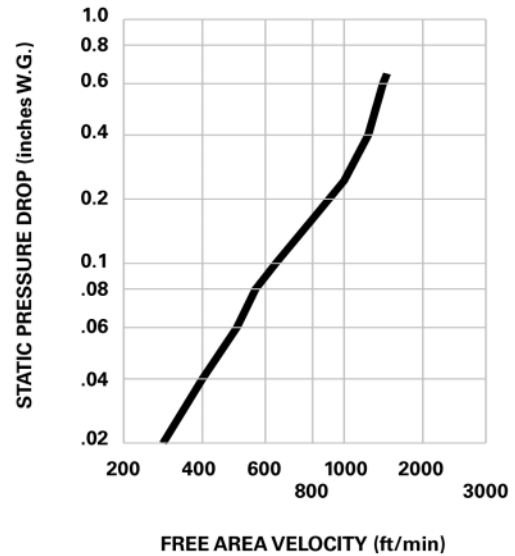

Dimensional Data

Wall Box, Vertical Louver

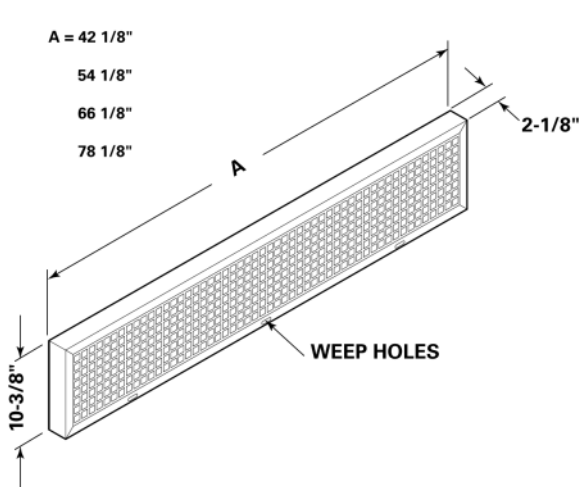

**V2 - VERTICAL LOUVER
with Lattice**

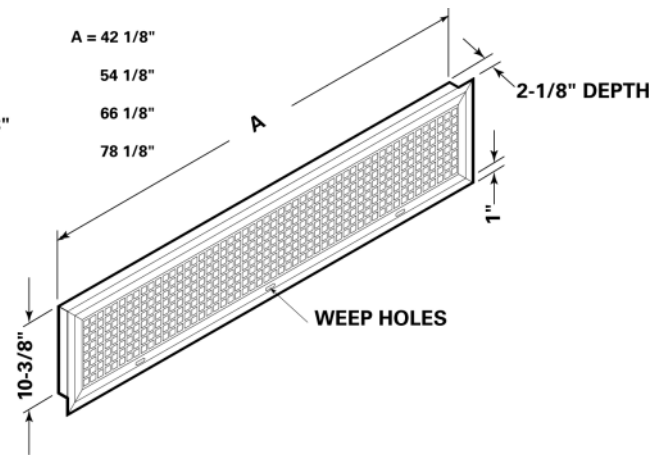

**V6 - VERTICAL LOUVER with Lattice
and 1-inch recessing flange**

Unit Size	A	Square Feet of Free Area
075	42 1/8"	1.035
100	54 1/8"	1.345
125	66 1/8"	1.681
150/200	78 1/8"	1.992

NOTE:
THE DIMENSIONS LISTED ABOVE ARE ACTUAL
(NOT NOMINAL) DIMENSIONS.

THE VERTICAL BLADES OF THE V2 AND V6 WALL
BOXES ARE SPACED 3/8" APART.

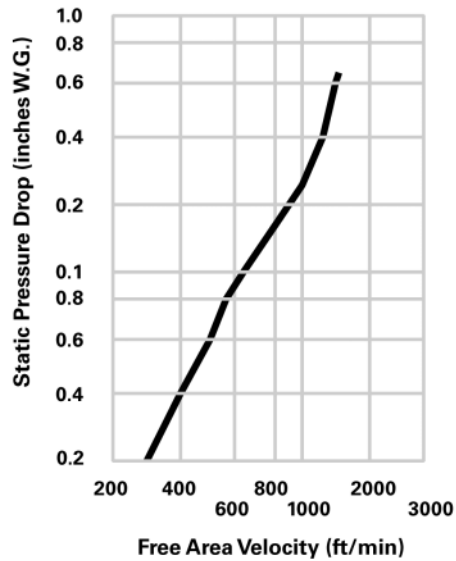



Mechanical Specifications

Energy Recovery Ventilator

Cabinet: The unit cabinet is a durable, furniture quality steel with exposed edges rounded. Quick acting, key-operated camlocks are provided for removal of the front panel.

Cabinet insulation is a foil faced, acoustically and thermally lined insulation. The exposed side is a high density erosion proof material suitable for use in airstreams up to 4500 FPM.

Fan Motor: The motor is a permanent split capacitor type, 3-speed motor, resiliently mounted with integral thermal overload protection and permanently lubricated ball bearing. The motor is factory run tested.

Fans: The fans are centrifugal forward-curved, double-width, double-inlet corrosion resistant wheels, statically and dynamically balanced, direct driven. Fans are a draw through configuration relative to energy recovery heat exchanger.

Heat Exchanger: The total energy recovery wheel is constructed of two separate air streams flowing in a counter flow configuration. The heat exchanger has a minimum effectiveness of 75-percent enthalpy energy exchange. Sensible "only" energy recovery is not acceptable.

The energy recovery wheel is maintenance free and rated for the life of the equipment. Units utilizing the rotating wheel heat exchanger contain a self-adjusting, belt drive motor with permanently lubricated bearings.

Unit Frost Prevention: Units do not require a means of frost prevention if the energy recovery wheel will not operate when the outside air temperature is below the frost threshold temperature (T_{TH}). The frost threshold temperature is dependent on the winter room relative humidity (RH) of:

- $T_{TH} = 5^{\circ}\text{F}$ at 30% RH
- $T_{TH} = 10^{\circ}\text{F}$ at 40% RH
- $T_{TH} = 15^{\circ}\text{F}$ at 50% RH

Units with electric preheat for frost prevention receive power from the space mechanical air conditioning equipment for all unit functions, including fan motor and controls. Energy recovery units with a separate power source include warning labels indicating that more than one disconnect is required to disable all power to the air conditioning units.

Filters: Exhaust and ventilation air streams are individually filtered prior to energy recovery heat exchanger. The exhaust air and ventilation air stream filter are easily removable.

Fresh Air/Exhaust Air Dampers:

The exhaust air discharge has a backdraft damper. The fresh air intake includes an ultra low-leak blade type air damper to ensure tight shut off. The damper seal is made of closed cell EPDM material. Leakage is less than one percent against 0.50 inches of external static pressure. Units provided with an outside air damper contain a factory mounted actuator.

Power Supply: Units without electric defrost receive power from space mechanical air conditioning unit for all unit functions including fan motors and controls. Energy recovery units with a separate power source include warning labels indicating that more than one disconnect is required to disable all power to the air-conditioning unit.

Controls: The units are interlocked with the space mechanical air conditioning units to ensure space ventilation during all occupied periods. Units are controlled by the adjacent unit ventilator to provide for economizer mode and allow for outside air to be used for free cooling.

Each energy recovery ventilator have a power relay in the control box to control the unit from the microprocessor based terminal board strategies: Occupied mode, fan operation, unoccupied operation, economizer control, electric defrost control and morning warm-up/cool down.

Mechanical Specifications

Shelving and Accessories

Unit ventilator shelving is manufactured from durable cabinet steel and painted in decorator colors as specified by the architect/engineer. The shelving cabinet is equipped with adjustable shelves, reinforced with a formed channel for maximum strength. Closed shelving doors are equipped with a locking device.

The unit ventilator shelving is available with a decorative and protective Formica™ top to compliment the unit cabinetry.

Shelving options include:

- Matching grilles
- Dynamic (draft) barrier shelving
- Cut-to-fit-filler
- Piping compartment
- Open/closed shelving

Shelving units contain leveling legs and hardware required to mate the shelving with the classroom unit ventilator or energy recover ventilator.

Sidewall Power Exhaust

A sidewall power exhaust is housed in a cabinet similar to the unit ventilator. The cabinet constructed of industrial grade steel with adjustable leveling legs at four corners. The front panel is constructed of heavy gauge metal and secured by three camlock fasteners. The power exhaust unit provides a nominal 500 or 750 cfm with a two speed switch. All motors are 115/60/1 voltage with direct drive fan(s).

Wall boxes

Trane wall boxes provide year-around moisture (droplet) free, outdoor air intake directly to the unit ventilator through the exterior classroom wall. Wall boxes are available in six standard arrangements to meet installation requirements on virtually any type of building construction.

All Trane wall boxes are constructed of extremely heavy gauge material and designed to last the life of the building. Internal parts are interlocked in addition to being held securely in place by the frame-within-a-frame design. This assures proper louver alignment. In addition, the strength of the vertical louver design simplifies installation by eliminating the need for a lintel. Wall boxes contain a 1/2-inch square mesh galvanized screen on the inside of the louver.

Gravity Relief Dampers

The gravity relief dampers are a barometrically operated, aluminum bladed design. The gravity relief damper is provided with optional wall boxes.



Trane
A Business of American Standard Companies
www.trane.com

For more information, contact your local district office or e-mail us at comfort@trane.com



Literature Order Number	UV-PRC005-EN
File Number	PL-TD-000-UV-PRC005-EN-0306
Supersedes	PL-TD-000-UV-PRC005-EN-1104
Stocking Location	Inland

Trane has a policy of continuous product and data improvement and reserves the right to change design and specifications without notice.