



# Installation Operation & Maintenance

---

## Vertical and Horizontal Classroom Unit Ventilators

Order No: UV-SVN02B-EN

Date: February 2005

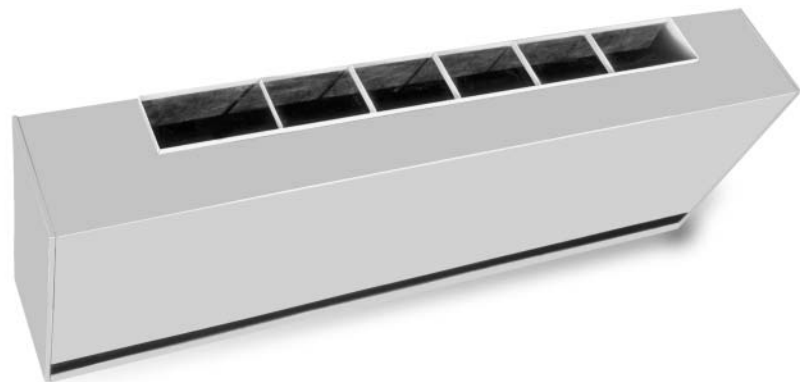

---

**UV-SVN02B-EN**

# Notice

---

## Notice

Warnings and Cautions appear at appropriate sections throughout this manual. Read these carefully.

**⚠ WARNING** - Indicates a potentially hazardous situation which, if not avoided, could result in death or serious injury

**⚠ CAUTION** - Indicates a potentially hazardous situation which, if not avoided, could result in minor or moderate injury. It may also be used to alert against unsafe practices.

**CAUTION** - Indicates a situation that may result in equipment or property damage only accidents.

# Contents

---

<b>General Information</b>	<b>4</b>
<b>Receiving and Handling</b>	<b>8</b>
<b>Installation Drawings</b>	<b>9</b>
<b>Installation</b>	<b>19</b>
Location Considerations	19
Unit Mounting	20
Piping Installation	24
Valves	27
Wiring	31
<b>Electrical Data</b>	<b>42</b>
<b>Maintenance</b>	<b>43</b>
<b>Troubleshooting</b>	<b>47</b>
<b>Accessories</b>	
Wall Boxes	49
<b>Related Literature</b>	<b>52</b>

# General Information

## Configuration

The classroom unit ventilator is configured in both a:

- horizontal (ceiling mount)
- vertical (floor mount)

configuration. The units range from 750 cfm to 2000 cfm for the horizontal configuration, and from 750 cfm to 1500 cfm for the vertical configuration.

## Cabinet

The units are constructed of 14- and 16-gauge zinc coated steel. All steel surfaces are cleaned, phosphatized, rinsed and dried before application of final finish paint. The paint is applied by an electrostatic powder spray system, minimum thickness of 1.5 mil which results in an appliance grade finish.

## Front Panels

The front panels are retained by Allen wrench operated locks which open with a 180-degree rotation. The vertical front panel is constructed of either 14 or 16 gauge material dependent upon model option selected.

## End Pockets

Unit Ventilators are equipped with end pockets to provide field installation of valves, piping, and controls. The units have a large pipe access opening in both end pockets and large knockouts for piping and electrical connections. All electrical connections are made in the left-hand end pocket, with exception of units equipped with the electric heating coil option.

## Drain Pan

The drain pan is positively sloped in all planes to assure proper drainage and help eliminate the risk of microbial growth. To help ensure indoor air quality, the drain pan is insulated on the bottom to help prevent condensate formation. The drain pan can be easily removed for cleaning purposes. A drain plug is located on each end of the drain pan on the vertical unit. The drain pan is drilled-out and pitched toward the

cooling coil connection during assembly per model number selection.

## Fanboard

The fanboard assembly is acoustically designed in a single, rigid assembly that includes the fans, fan housing, bearings, fan shaft and motor. The fan motor is mounted on the fanboard. The fanboard is made from 14 gauge galvanized steel to resist corrosion and increase strength.

## 115V Motor

The motor is a single speed permanent split capacitor with thermal overload protection. A multiple tap auto-transformer is wired to the motor to provide different speed settings. The motor speed is not affected by damper positions. Standard motors are rated up to 0.25 ESP. High static motors are rated from 0.25 ESP to 0.45 ESP.

Motor bearings are permanently lubricated. Isolation of the motor is provided internally at the union shaft.

## Sampling Chamber (Option)

A sampling chamber is provided for housing the room air sensor whenever a unit mounted sensor is specified for Tracer ZN520 controls (Figure 1). The sampling chamber is placed below the air-coil where room air is continuously drawn into the chamber before being tempered by the coil. This ensures an accurate response to temperature changes in the room.

## Filter

Standard units are equipped with a single 1-inch thick filter that is accessible without removal of the unit front panel. Filter options include throw-away and permanent renewable.

Dynamic air barrier units contain two filters (1-standard/1-return air). The return air filter requires front panel removal for filter access.

## OA/RA Damper

Trane unit ventilators are equipped with dual blade type mixing damper to ensure proper modulation and mixing of return and outdoor air designed in accordance to ARI 840. A splitter is placed between the damper blades to separate the fresh-air and return-air compartments to prevent draft blow-through.

An ultra low-leak damper seal is applied on all vertical unit configurations. The seal consist of a medium density, closed-cell neoprene material. The seal is fixed and not part of the damper assembly. The outside-air damper closes into the closed cell neoprene material, providing a positive pressure seal.



**Figure 1:** Sampling Chamber

# General Information

## OA/RA Actuator (Option)

The OA/RA actuator provides true spring return operation for positive close-off of the OA/RA damper. The spring return system of the actuator closes the outside damper if power is lost to the building. When ordered with factory mounted controls, the actuator is 3-point floating. A 2 to 10 VDC actuator is also available when other than Trane controls is required. See Table 1 for technical data of the OA/RA actuator.

## Face and Bypass (Option)

The face and bypass option consist of an actuator, damper blade and 2-position water valve (option).

During bypass mode, the damper moves to prevent air from traveling through the coil. The damper blade is tightly sealed to eliminate heat pickup while in the full bypass mode.

A two-position isolation valve control (option) further enhances this system by closing off all water flow to the coil during full bypass operation. 2-pipe main steam systems utilize the face and bypass as part of the standard operation and may incorporate the optional isolation valve.

## Face and Bypass Actuator (option)

The face and bypass damper actuator incorporates a direct couple design for both the horizontal and the vertical configurations. The actuator is provided with electronic protection against overload. It does not contain, nor require a limit switch. When reaching the damper end position, the actuator automatically stops. The gears can be manually disengaged with a button on the actuator housing. See Table 2 for technical data.

**Table 1:** Technical Data for OA/RA actuator



Power Supply	24VAC $\pm$ 20% 50/60HZ 24VAC $\pm$ 10%
Power Consumption	Running: 2.5W Holding: 1W
Transformer Sizing	5VA (class 2 power source)
Overload Protection	Electronic throughout 0 to 95-degree rotation
Control Signal	2-10 VDC 3 point floating w/ Trane controls
Rotation Angle	95-degree max. Adjustable w mechanical stop
Torque	35-inch/lb
Rotation Direction	Spring return reversible w/ CW/CCW mounting
Position Indication	Visual indicator, 0 to 95-degrees
Run Time	90-second constant
Noise Level	Running: 30dB

**Table 2:** Technical Data for face & bypass actuator



Power Supply	24VAC $\pm$ 20% 50/60HZ 24VAC $\pm$ 10%
Power Consumption	2W
Transformer Sizing	3VA (class 2 power source)
Manual Override	External push button
Control Signal	3 point floating w/ Trane controls
Rotation Angle	95-degree max. Adjustable w mechanical stop
Torque	35-inch/lb
Rotation Direction	Reversible with switch L/R
Position Indication	Clip-on indicator
Run Time	90-second constant
Noise Level	Less than 35dB

# General Information

### Modulating Water Valves (Option)

The modulating control valve option provides optimum control of hot and chilled water flow in various heating and cooling applications. They are designed to provide sinusoidal valve actuator travel and operate silently, resisting water hammer.

The actuator on the valve is a 24V, 3-point floating type. See Table 3 for more technical data.

### Isolation Valves (Option)

The isolation valves are two position 24V, spring return type. They provide added control in heating and cooling applications when used in conjunction with the face and bypass damper.

On heating coils and two-pipe change-over applications, the valve is a normally open type to prevent the coil from freezing in case of power loss.

For cooling, the valve is normally closed and opens when there is a call for cooling. See Table 4, for more technical data.

**Table 3:** Technical Data for Modulating Water Valves

	
Power Supply	24V - 50/60 Hz
Power Consumption	4W
Maximum Duty Cycle	15%
Nominal Timing	120 sec.
Operating Ambient Temperature	0 to 65 C 32 to 150 F
Min./Max Fluid Temperatures	1 to 95 C 34 to 203 F
Operating Pressure Differential	Max. - 4 bar (60 psi)
Pressure Rating	Static- 20 bar (300psi) Burst- 100 bar (1500 psi)
Flow Characteristics	Linear

**Table 4:** Technical Data for Isolation Water Valves

	
Power Supply	24V - 50/60 Hz
Power Consumption	5W
Max. Fluid Temp.	200 F / 94 C
Min. Fluid Temp.	34 F / 1 C
Max. Operating Pressure	300 psi
Max. Close-off Pressure	1/2" = 30 psi 3/4" = 20 psi 1" = 15 psi

# General Information

## Unit Ventilator Controls

Controls are provided either by Trane as a factory-mounted option or furnished by an outside vendor and mounted at the job-site.

Units constructed for field installation of controls are shipped with one of the following type of controls:

- **No Controls/Field Installation:** (Option) The unit comes equipped with an auto transformer, fan speed switch and damper blade only.
- **End Device Package (EDP):** This option pre-wires optional control components to a terminal strip for wiring field provided controller and temperature sensor.

**NOTE:** For controller operation malfunction of any non-Trane, field-installed controls, consult the literature or technical support of the controls manufacturer.

Trane offers Direct Digital Controls for the unit ventilator. The **ZN520** (See Figure 2) unit controller is designed to provide control of the classroom unit ventilator and the fan coil products and adds increased functionality to the unit ventilator.

When Trane controls are ordered for an installation, the controls are shipped already installed and factory-tested to ensure proper operation at start-up.

**NOTE:** For more details on the ZN520 unit controller option or operation and service/replacement issues, please refer to **CNT-SVX04A-EN: Tracer ZN520 Unit Controller IOP**.

## Automatic Controls

Regardless of type of controls, all systems provide a sequence of operation designed to provide rapid warm-up of the room and increase ventilation while offsetting overheating.

In addition, air conditioning installations will usually provide a means of system changeover from heating to cooling as well as provisions for drawing a pre-determined amount of outside air into the room.

## Unit Switch

The unit "On-Off" switch, provided by Trane, is typically housed in the control box mounted in the left hand end pocket immediately below the discharge grille.

When Trane ZN520 unit controllers are used, the unit switch is located on the switch module in the end pocket behind the front panel rather than below the grille.

**Figure 2:** ZN520 unit controller

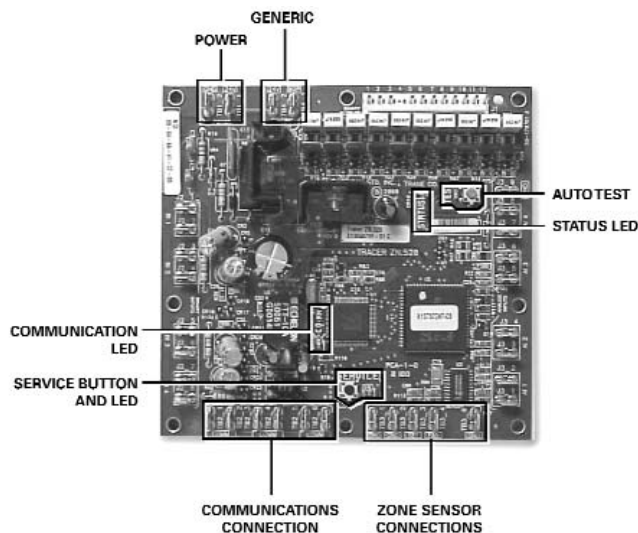

## Receiving and Handling

The unit ventilator is packaged in clear stretch wrap and protective to allow for immediate visual inspection. Vertical units are also shipped with a protective cardboard cover to help prevent scratching and other cosmetic blemishes during transport (Figure 3). Horizontal units are shipped with cardboard blocking on all edges for protection during shipping (Figure 4).

**NOTE:** Before unwrapping, make a visual inspection of the unit for any damage that may have occurred during shipping. All orders are shipped FOB (Free on Board) from the factory, therefore any claims must be made with the delivering carrier.

Following visual inspection, carefully begin the following procedures:

1. Carefully remove the stretch wrap and the top cardboard cover. *If end covers have been*



**Figure 3:** Vertical unit ventilator as shipped.

*ordered for vertical units, the panel will already be mounted to the unit.*

2. Remove remaining cardboard blocking
3. Remove the front (vertical) or bottom (horizontal) access panel with a 7/32" Allen wrench.
4. Verify nameplate sales order number is correct.
5. Remove shipping bracket from the lower rear corners of the unit and shipping skid. Access to the screws holding unit to the skid is obtained inside the unit.
6. Rotate fan wheels manually. Wheels should move freely and be in proper alignment. Visually inspect the fan area for obstructions or shipping damage.

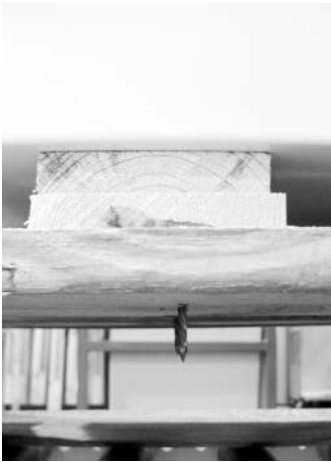

**Figure 5:** Shipping skid removal

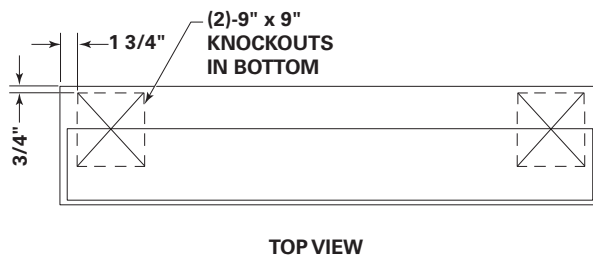
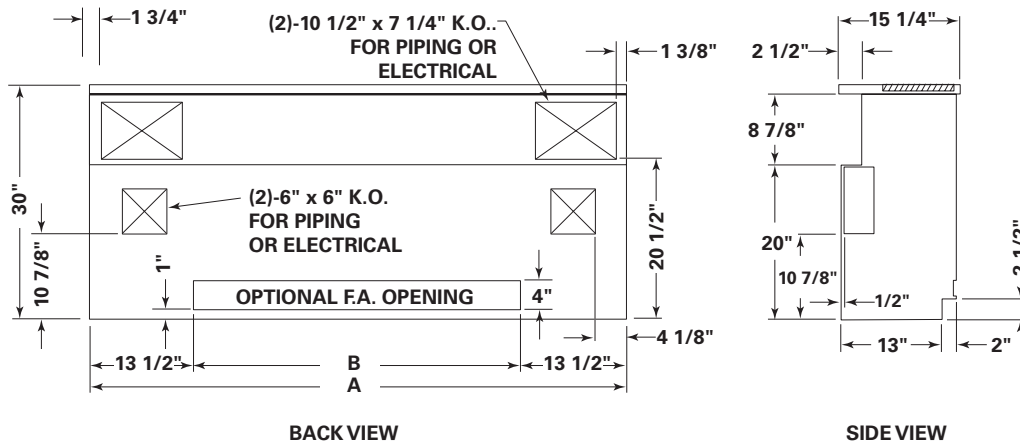

**Figure 4:** Horizontal unit ventilator as shipped.

# Installation Drawings

## VUV 15-1/4" Depth

**Figure 6:** Standard depth vertical unit ventilator dimensional data



Unit Size	# of Fans	A	B
075	2	69"	42"
100	3	81"	54"
125	4	93"	66"
150	5	105"	78"

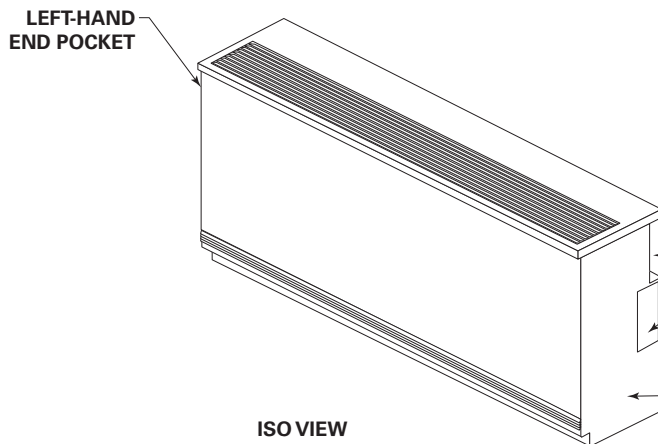

**NOTE:**

UNIT LENGTH DOES NOT INCLUDE 5/8" END COVERS.

THE POWER CONNECTION IS MADE IN THE LEFT HAND END POCKET FOR ALL OPTIONS EXCEPT ELECTRIC HEAT. THE POWER CONNECTION FOR ELECTRIC HEAT IS MADE IN THE RIGHT HAND END POCKET.

**NOTE:**

FOR UNITS EQUIPPED WITH CROSS-OVER PIPING: PIPING ENDS ARE FLUSH WITH UNIT END AND ARE RECESSED IN CUTOUT SPACE PROVIDED AS SHOWN.

CROSSOVER PIPING IS EITHER 1-3/8" OD OR 2-1/8" OD.

# Installation Drawings

## VUV 16-1/4" Depth

**Figure 7:** 1-inch falseback vertical unit ventilator dimensional data

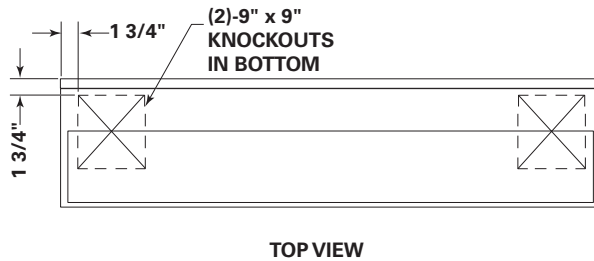
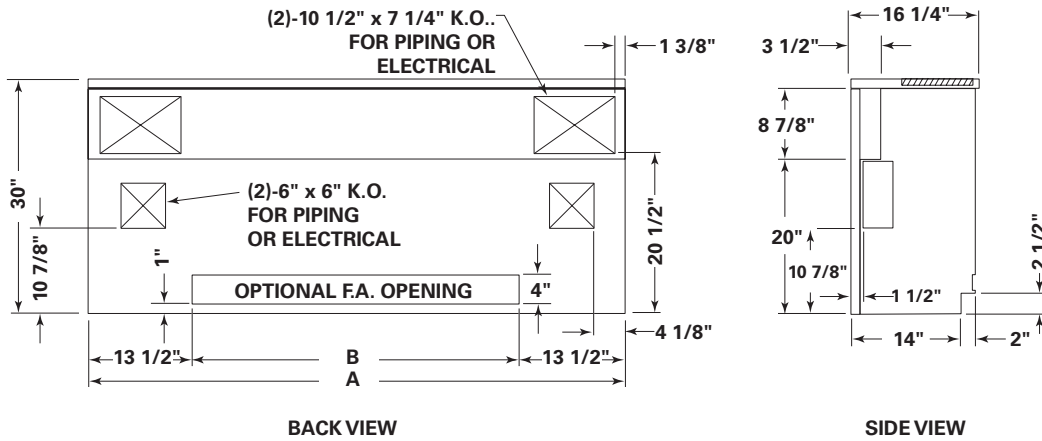

Unit Size	# of Fans	A	B
075	2	69"	42"
100	3	81"	54"
125	4	93"	66"
150	5	105"	78"

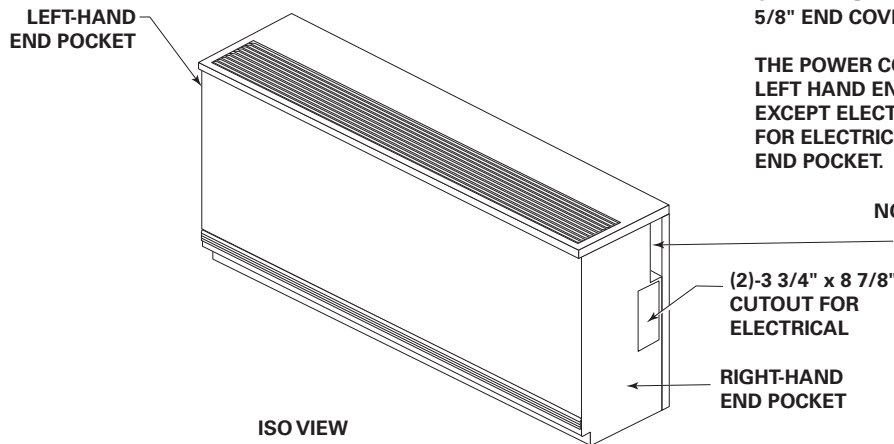

**NOTE:**

UNIT LENGTH DOES NOT INCLUDE 5/8" END COVERS

THE POWER CONNECTION IS MADE IN THE LEFT HAND END POCKET FOR ALL OPTIONS EXCEPT ELECTRIC HEAT. THE POWER CONNECTION FOR ELECTRIC HEAT IS MADE IN THE RIGHT HAND END POCKET.

**NOTE:**

FOR UNITS EQUIPPED WITH CROSS-OVER PIPING: PIPING ENDS ARE FLUSH WITH UNIT END AND ARE RECESSED IN CUTOUT SPACE PROVIDED AS SHOWN.

CROSSOVER PIPING IS EITHER 1-3/8" OD OR 2-1/8" OD.

# Installation Drawings

## VUV 21-1/4" Depth

**Figure 8:** 6-inch falseback vertical unit ventilator dimensional data

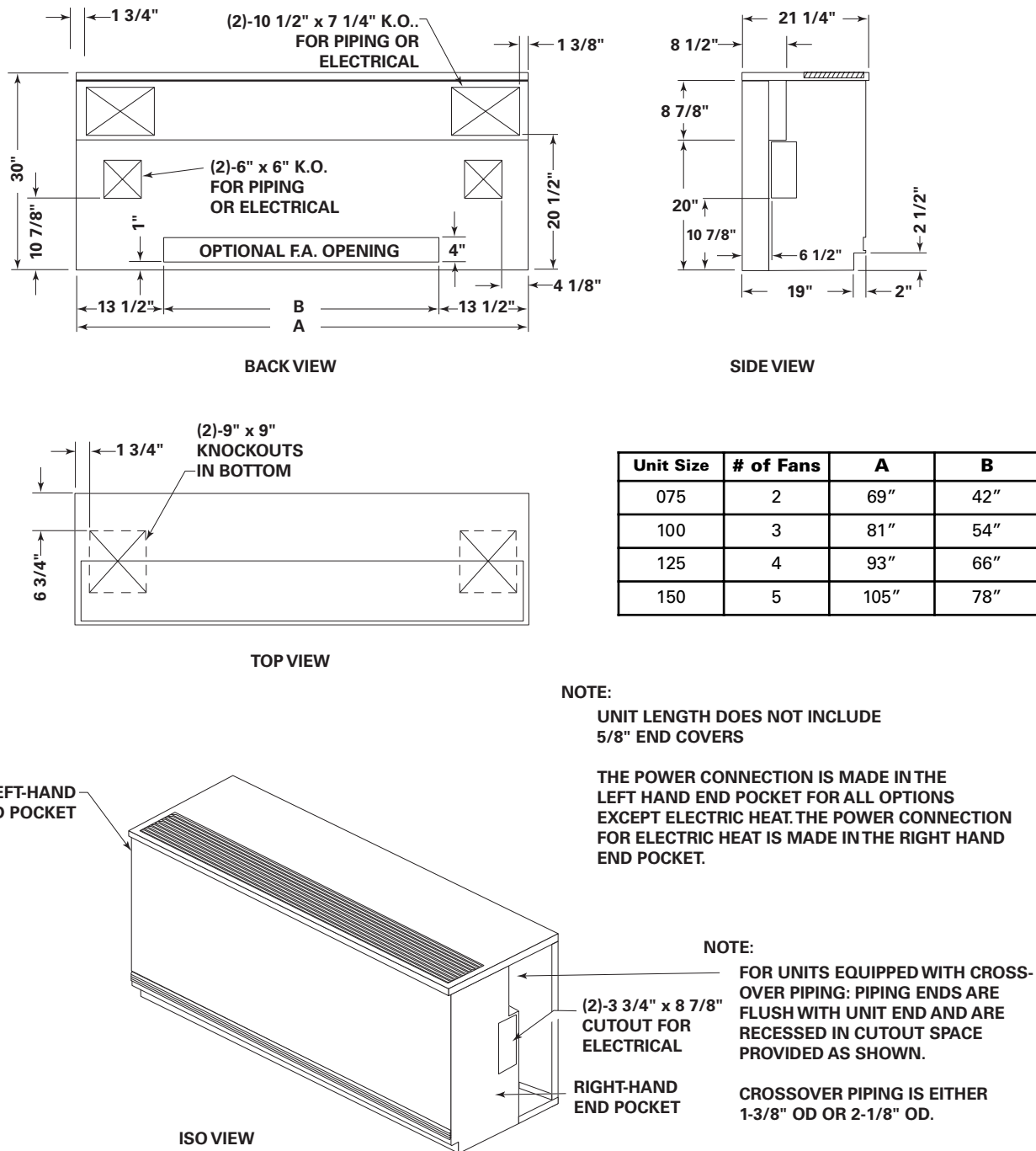

# Installation Drawings

## VUV Ducted Inlet

**Figure 9:** 6-inch falseback vertical unit ventilator with ducted inlet dimensional data

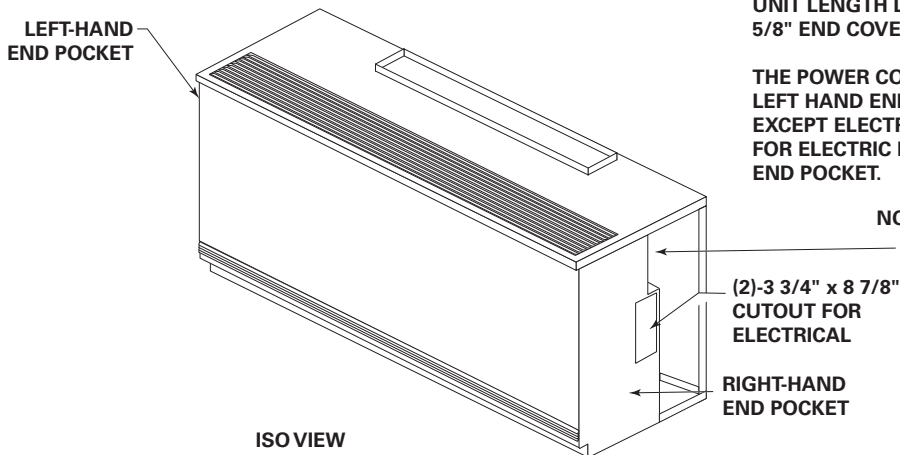
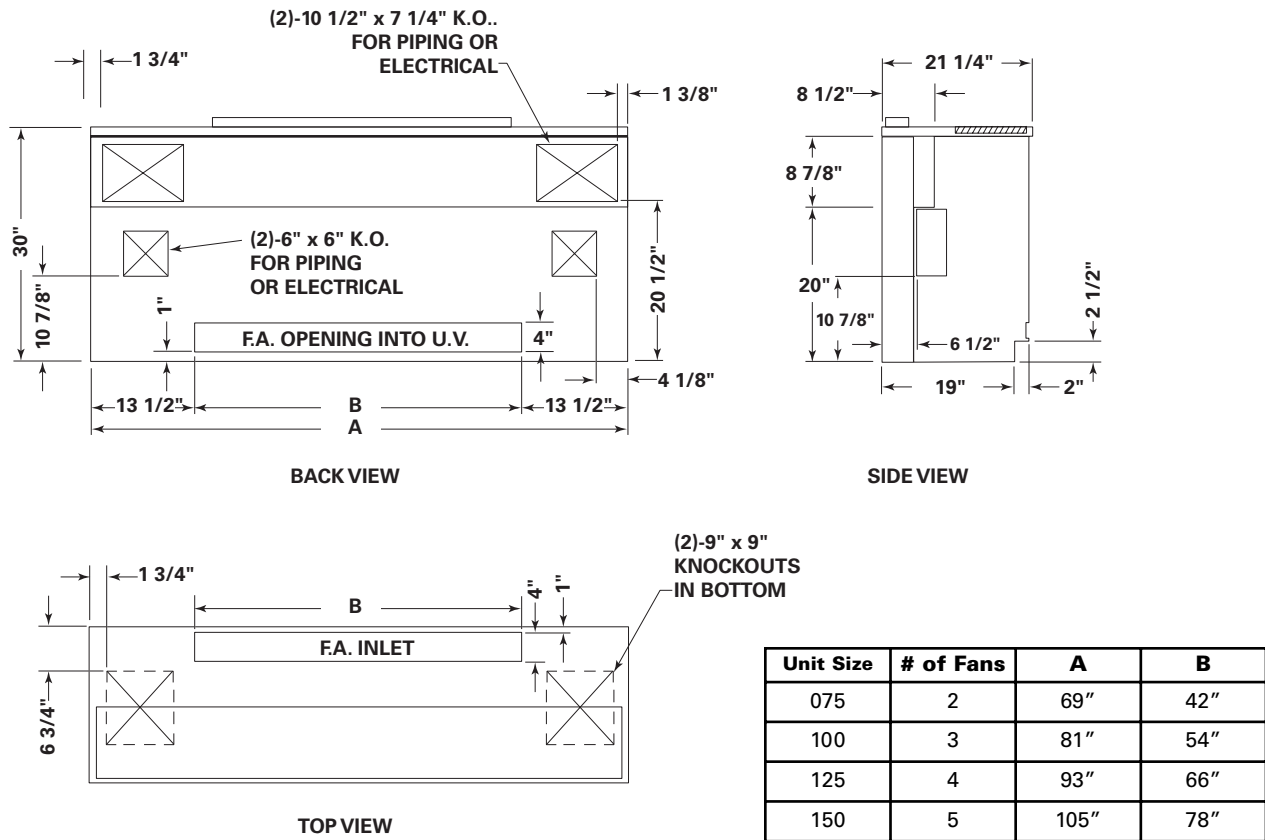

**NOTE:**

UNIT LENGTH DOES NOT INCLUDE 5/8" END COVERS

THE POWER CONNECTION IS MADE IN THE LEFT HAND END POCKET FOR ALL OPTIONS EXCEPT ELECTRIC HEAT. THE POWER CONNECTION FOR ELECTRIC HEAT IS MADE IN THE RIGHT HAND END POCKET.

**NOTE:**

FOR UNITS EQUIPPED WITH CROSS-OVER PIPING: PIPING ENDS ARE FLUSH WITH UNIT END AND ARE RECESSED IN CUTOUT SPACE PROVIDED AS SHOWN.

CROSSOVER PIPING IS EITHER 1-3/8" OD OR 2-1/8" OD.

# Installation Drawings

## VUV Ducted Inlet/Discharge

**Figure 10:** 6-inch falseback vertical unit ventilator with ducted inlet and return air discharge dimensional data

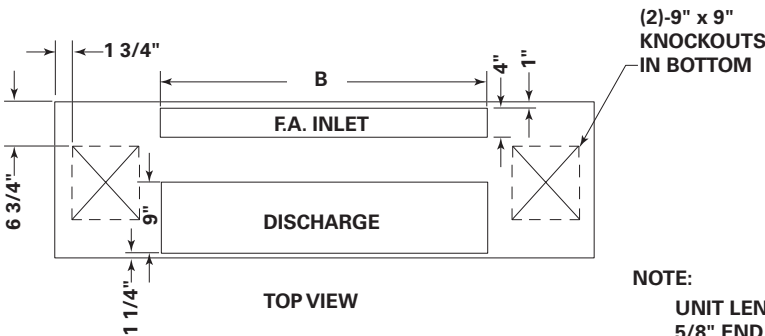
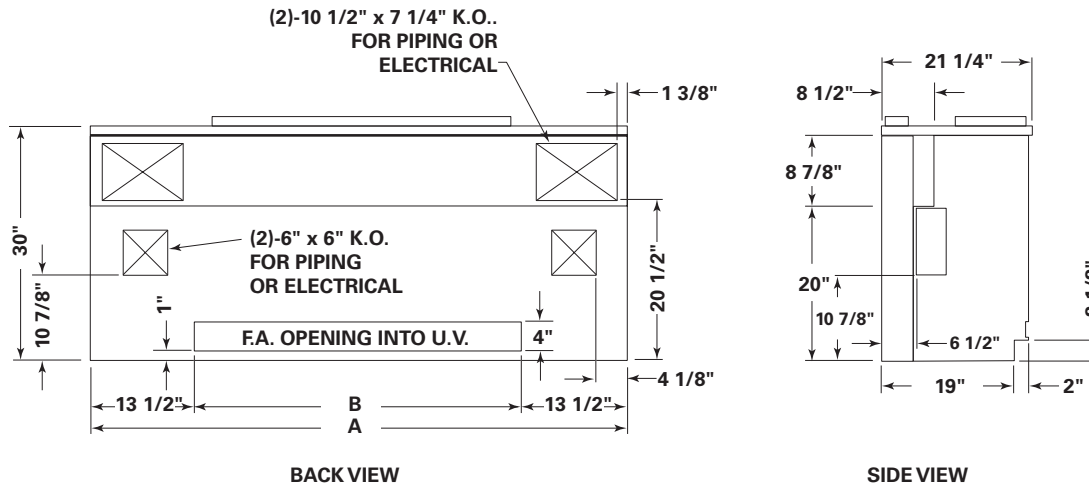

Unit Size	# of Fans	A	B
075	2	69"	42"
100	3	81"	54"
125	4	93"	66"
150	5	105"	78"

**NOTE:**

UNIT LENGTH DOES NOT INCLUDE 5/8" END COVERS

THE POWER CONNECTION IS MADE IN THE LEFT HAND END POCKET FOR ALL OPTIONS EXCEPT ELECTRIC HEAT. THE POWER CONNECTION FOR ELECTRIC HEAT IS MADE IN THE RIGHT HAND END POCKET.

UNIT MOUNTED FAN SPEED SWITCH IS ROTATED AND ACCESSED THROUGH THE FRONT PANEL WHEN UNIT AIR DISCHARGE IS DUCTED.

**NOTE:**

FOR UNITS EQUIPPED WITH CROSS-OVER PIPING: PIPING ENDS ARE FLUSH WITH UNIT END AND ARE RECESSED IN CUTOUT SPACE PROVIDED AS SHOWN.

CROSSOVER PIPING IS EITHER 1-3/8" OD OR 2-1/8" OD.

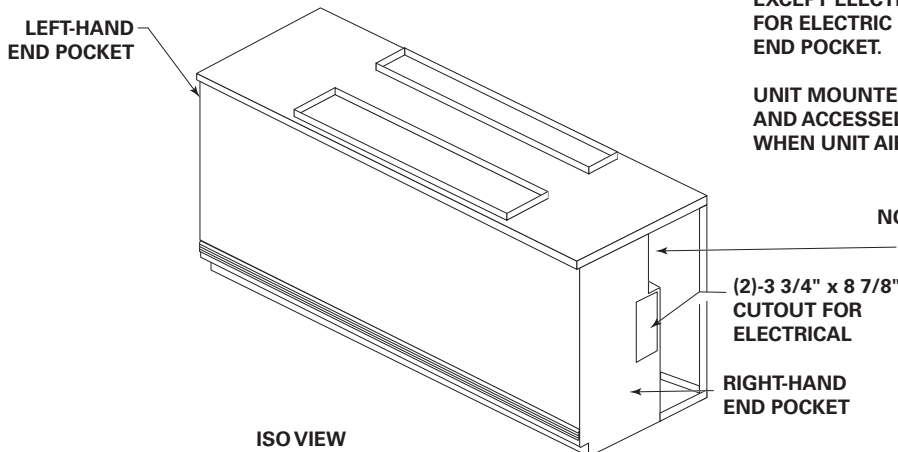

# Installation Drawings

## HUV Ducted Front Discharge

**Figure 11:** Horizontal unit ventilator with ducted front discharge dimensional data. Sizes 075-150

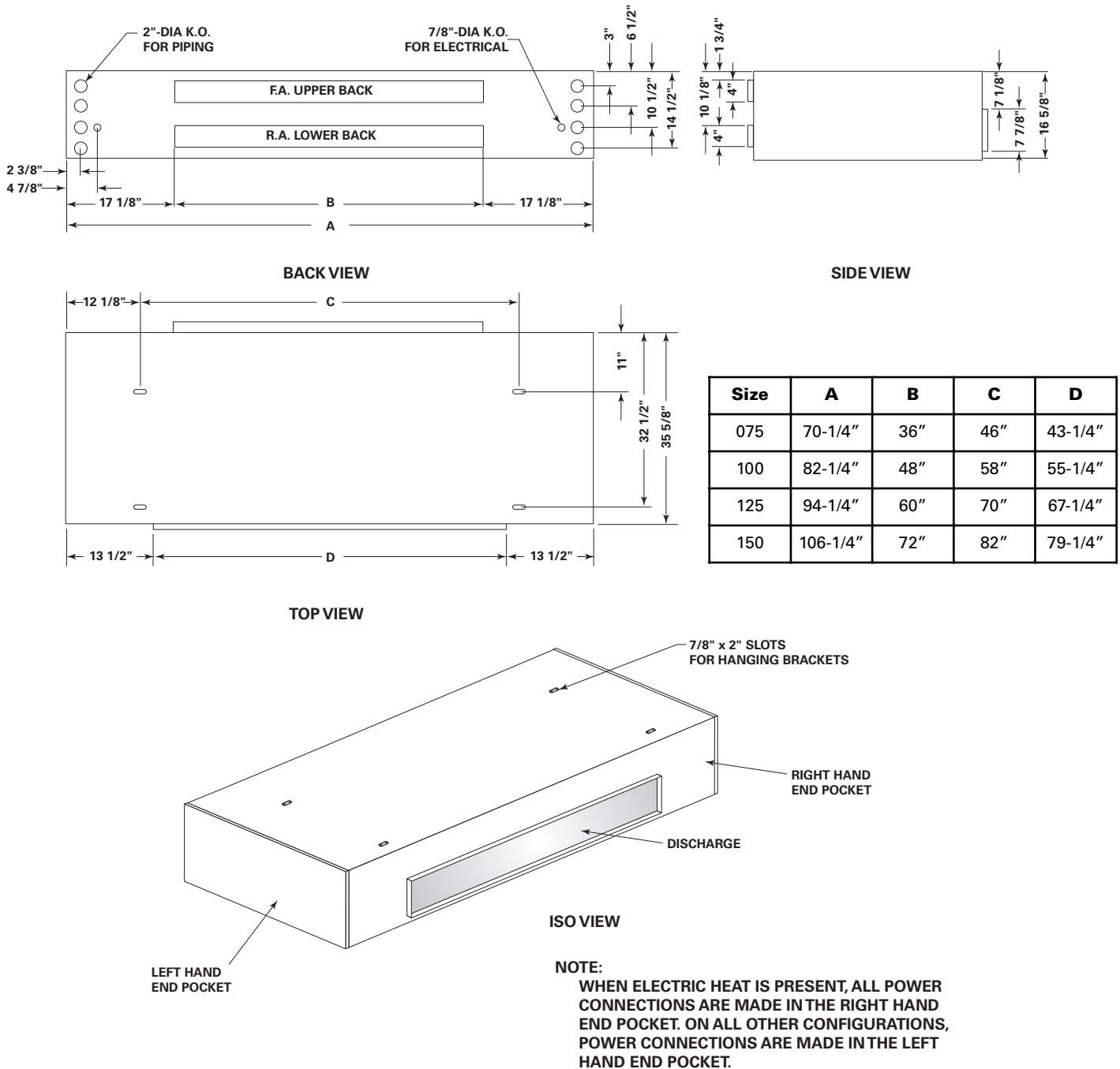

# Installation Drawings

## HUV Ducted Front Discharge

**Figure 12:** Size 200 horizontal unit ventilator with ducted front discharge dimensional data

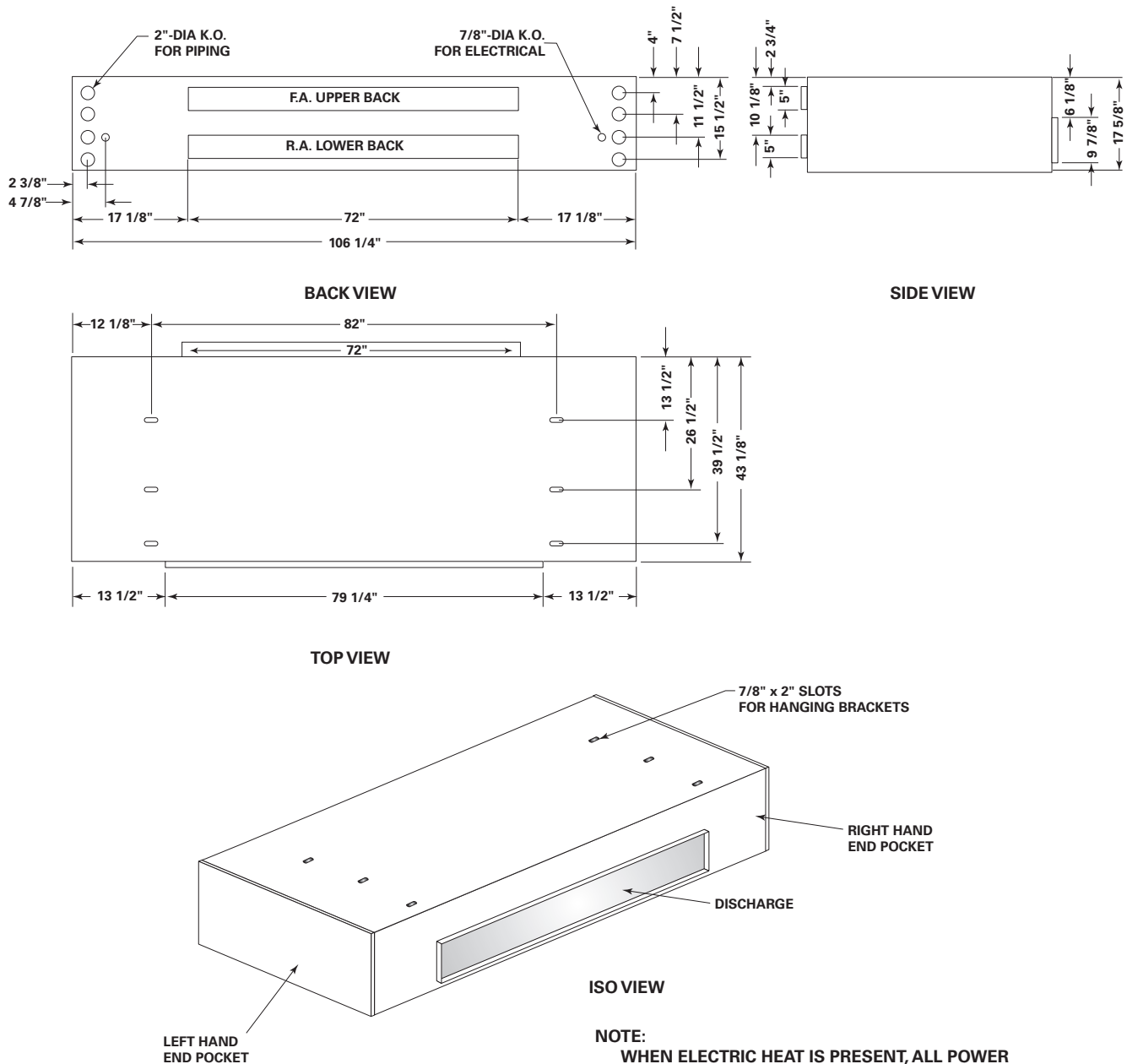

**NOTE:**  
 WHEN ELECTRIC HEAT IS PRESENT, ALL POWER CONNECTIONS ARE MADE IN THE RIGHT HAND END POCKET. ON ALL OTHER CONFIGURATIONS, POWER CONNECTIONS ARE MADE IN THE LEFT HAND END POCKET.

# Installation Drawings

## HUV Bottom Double Deflection Discharge

**Figure 13:** Double deflection discharge horizontal unit ventilator dimensional data. Sizes 075 - 150

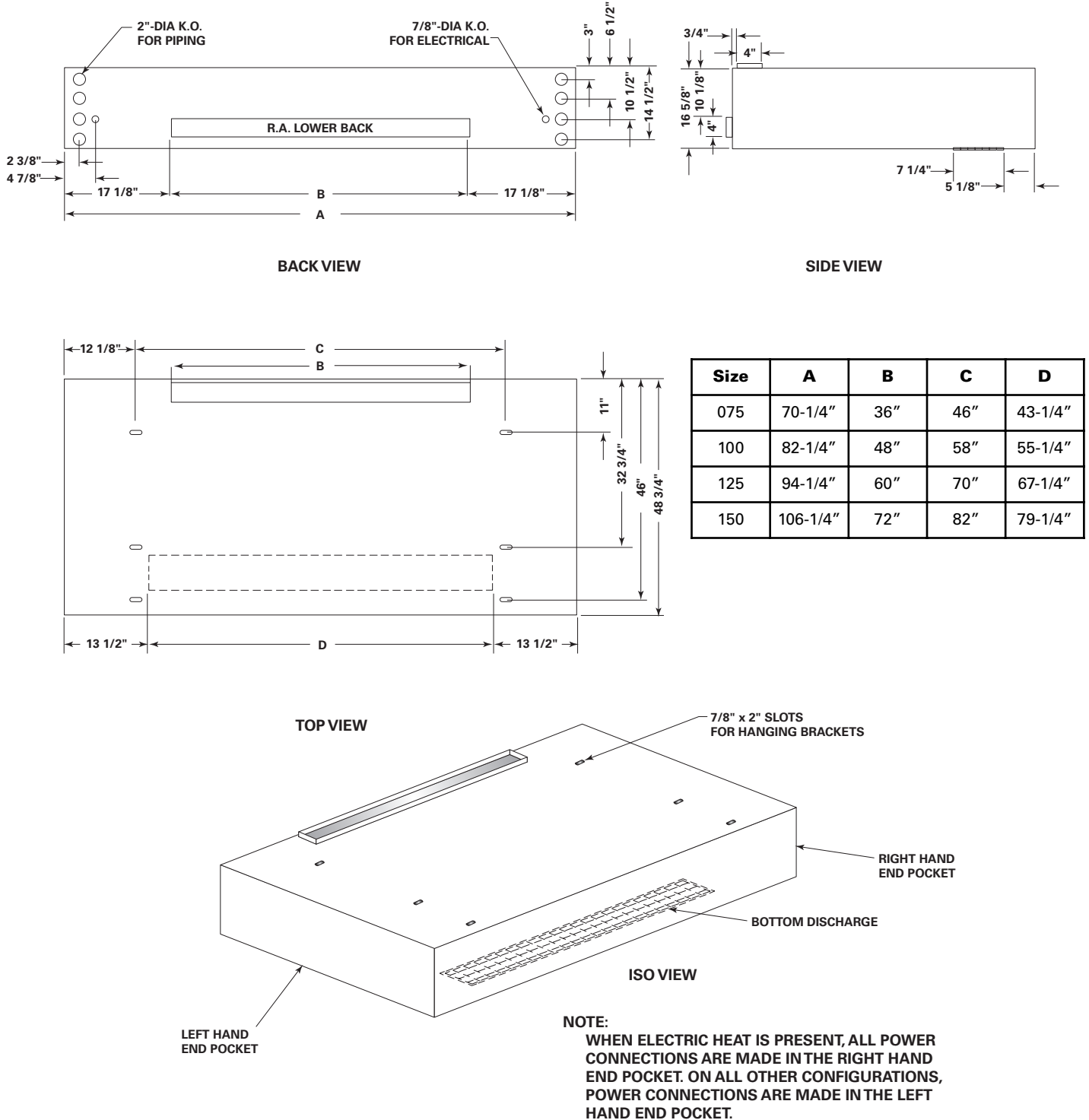

# Installation Drawings

## HUV Bottom Double Deflection Discharge

**Figure 14:** Double deflection discharge horizontal unit ventilator dimensional data. Size 200

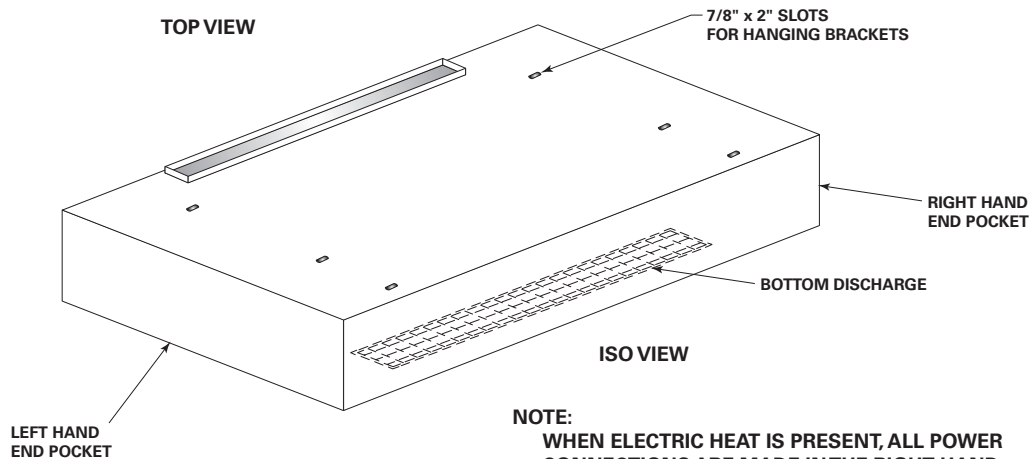
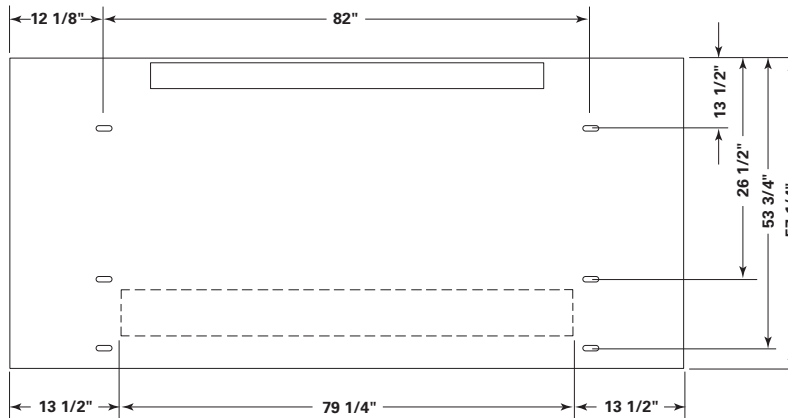
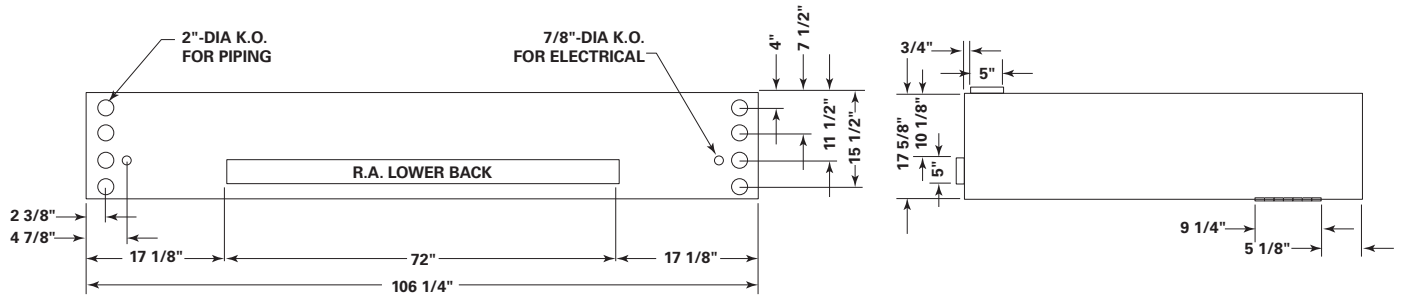

**NOTE:**  
 WHEN ELECTRIC HEAT IS PRESENT, ALL POWER CONNECTIONS ARE MADE IN THE RIGHT HAND END POCKET. ON ALL OTHER CONFIGURATIONS, POWER CONNECTIONS ARE MADE IN THE LEFT HAND END POCKET.

# Installation Drawings

## HUV Inlet Arrangements

**Figure 15:** Supply/return air arrangements for the HUV

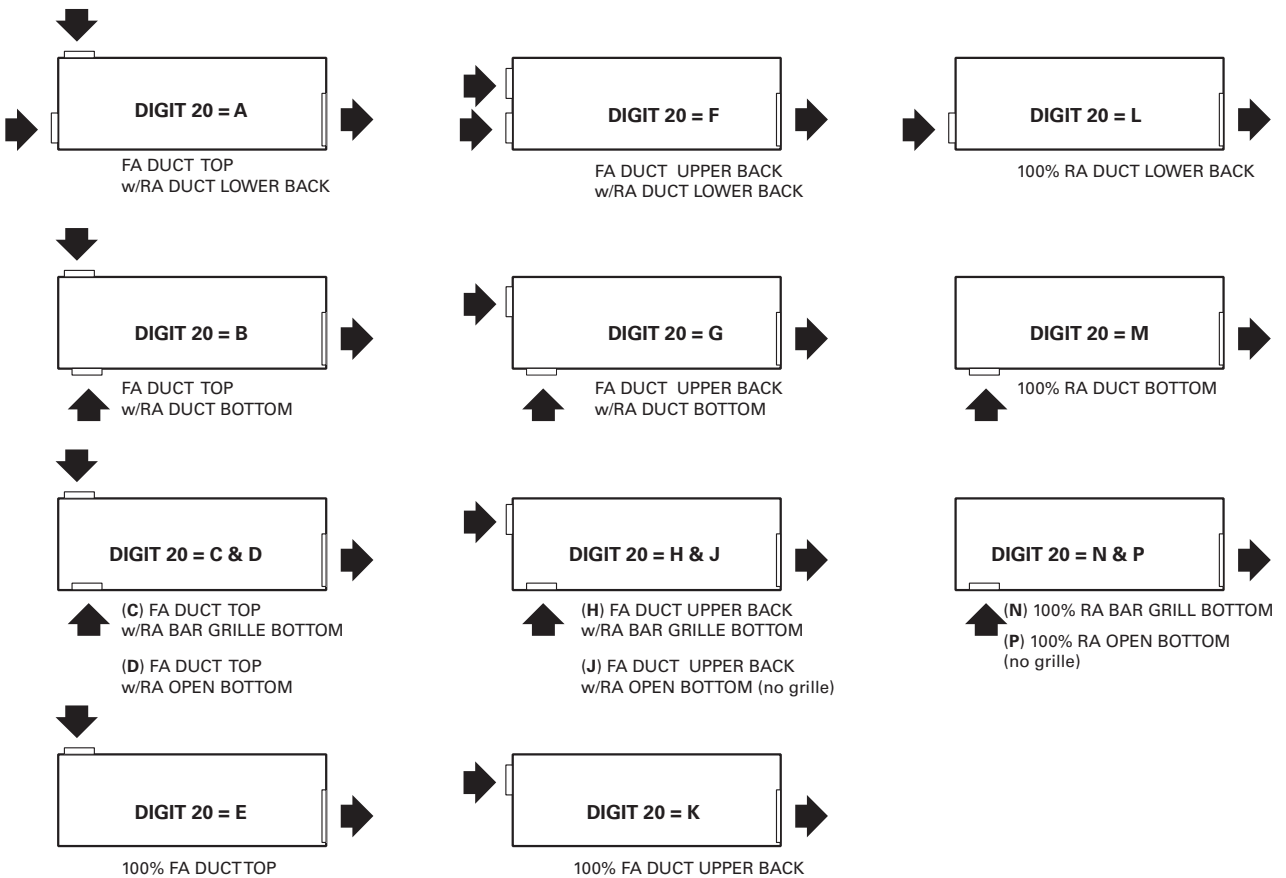
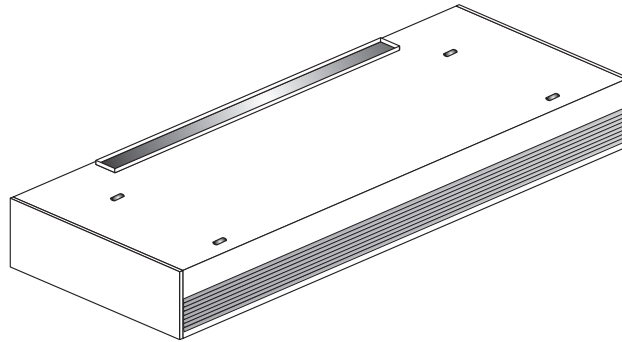

# Installation

## Location Considerations

Selecting the appropriate location for installing a unit is very important. The following factors should be considered:

### Vertical Unit Ventilators

1. Floor design must have sufficient structure to withstand the weight of the unit while allowing for openings in the floor for a Return Air duct, electrical and piping supply lines fed through the floor. See Figures 6-10 for unit dimensions and Table 5 for unit weights.

**Table 5:** Typical unit weights\*

Unit Size	Vertical Unit lbs (kg)	Horizontal Unit lbs (kg)
070	320 (145)	340 (154)
100	405 (184)	375 (170)
120	450 (204)	435 (197)
150	470 (213)	500 (227)
200	NA	600 (272)

\* Weight at time of shipping. Subtract approx. 10% for actual hanging weight.

2. Wall space design should allow the unit to be mounted to the wall securely. The wall surface behind the unit should be smooth and level. A wall slightly out of level may cause problems with unconditioned air leaking into the room. Remove any object projecting more than 1/8" (.3175cm) from the wall surface. **NOTE:** Additional gasketing may be installed to accommodate for uneven wall.

3. There are two removable knock-outs in the rear of the unit, on either end, for piping and electrical supply lines. A pipe chase is located in the upper back portion of the unit for crossover piping (See Figures 6-10). The Fresh Air opening is located in the lower back of the unit and the path to the wallbox on the outside wall should be

unobstructed.

- The physical layout of the room should accommodate any accessories ordered with the unit. Conditioned air is distributed through the grille on top of the unit and returned through the return air grille on the bottom of the unit. Avoid placing any objects that may obstruct either grille or interfere with airflow.
  - Internal access to the unit is provided by the removable front panel. Sufficient space should be allowed to lift the panel for maintenance purposes.
  - Make sure the unit is placed on a level surface. The unit leveling legs can also be adjusted to accommodate slight out-of-level installation surfaces.
- ### Horizontal Unit Ventilators
- Ceiling hung design must be of sufficient structure to support the weight of the unit. See Table 5 for weight data. Figures 11-14 show hanging rod location and placement. **NOTE:** Isolator and suspension rods are to be provided by the installer. Trane recommends 3/8" rods for hanging suspension.
  - Service access is gained through the access panels on the bottom of the unit. Sufficient space should be allowed for panel removal. If the hinged panel option is ordered, allow for a swing radius of 14".

### Vertical and Horizontal Units

- Sufficient free area around both the discharge and wall box should be maintained to ensure proper ventilation. If any part of the discharge is blocked off, unit performance may be effected. If the wall box is too small on the inlet, water or debris could be

pulled into the unit. See Table 6 for minimum wall box free area requirements.

**Table 6:** Wall box free area requirements

Unit Size	Discharge sq. in.		Inlet sq. in. Vert./Hor.
	Vert./Hor.	Vert./Hor.	
070	290	232	169
100	370	296	217
120	450	364	265
150	530	430	313
200	NA	576	391(Hor.)

- Use the shortest and most efficient ductwork possible when ducting the discharge and/or return air grille. Units ordered with a duct collar discharge arrangement are equipped with a 1" duct flange. **NOTE:** Ductwork for ducted units will be provided by the installer.
- If installing a split system, refer to the condenser installation instructions provided with that unit for special location considerations. **NOTE:** Measurements in Figures 6-10 do not include adjusted leveling legs. Adjustment of Leveling legs should be done first. New measurements from the floor should be retaken before installation.

# Installation

## Vertical Unit Ventilator

### Subbase

A subbase may be used to increase the unit height and aid in leveling the unit. The subbase is shipped separately for field installation. Slots and leveling screws are provided on the subbase.

1. Remove the leveling legs provided with the unit. See Figure 16.
2. Set the unit on the subbase and fasten with 4-3/8" x 16' x 1-1/2" hex head cap screws. **NOTE:** Hex screws provided by installer. Pre-drilled slots in the subbase flange will line up with the weld nuts in the bottom of the unit.
3. The bottom of the subbase has weld nuts in four slots. Place the leveling legs in those slots and level the unit.

### Unit Mounting

**NOTE:** All wall intake boxes should be installed prior to mounting the unit ventilator. Refer to Page 49 for wall box installation instructions.

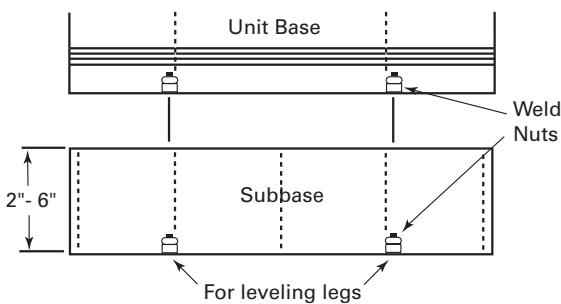

**Figure 16:** Subbase installation with leveling legs

### Vertical Unit Ventilator

The 1/2" mounting or anchoring holes are located on the back of the unit on each end. See Figures 17 and 18.

**NOTE:** All mounting fastener are to be provided by the installer.

1. Take care not to bend the front return air grille while handling the unit
2. Check the gasket on the rear of the unit and around the fresh air opening. Gaps around the openings can lead to outside air leaks into the room.
3. Remove all electrical and piping knockouts where required for installation.
4. Set the unit in its selected location and adjust leveling legs if necessary to ensure level fit. See Figure 16.

**Note:** Unit must remain level. Coils and drain pans inside the unit are pitched properly for draining before shipment.

5. Push the unit tightly against the wall to compress the seal on the back edge of the unit and intake opening. Anchor the unit by using the 1/2" mounting holes in both end pockets. See Figures 17 & 18.
6. Make sure the unit rests tightly against the wall. Check for proper seal and that air does not leak underneath the unit.
7. Replace all covers, panels and filters before starting the unit.

**Figure 17:** Mounting holes for standard 15-1/4" & 16-1/4" depth unit ventilator

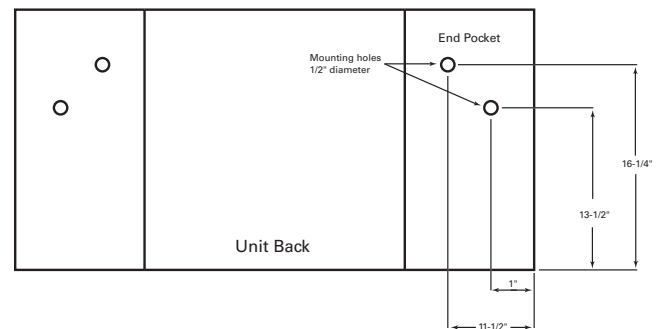

**Figure 18:** Mounting bracket with 1/2" mounting holes for 21-1/4" depth unit ventilator.

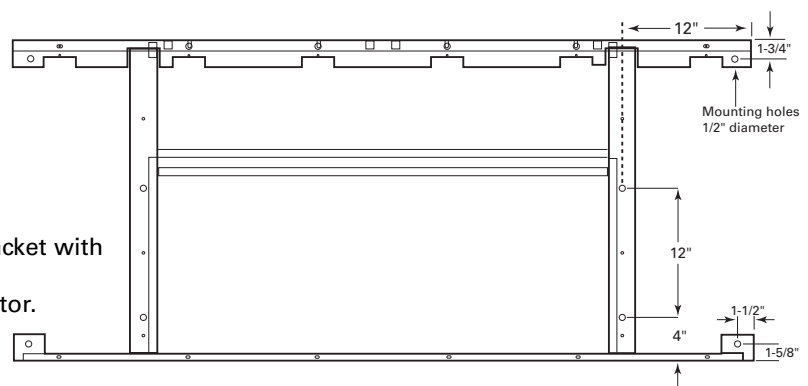

# Installation

## Recessed vertical units (Option)

The optional recessing flange assembly includes pre-cut flanges, corner transition pieces, mounting screws, filler pieces and pressure sensitive gaskets. Refer to **Figure 19** for a typical vertical installation. To install the recessing flange, complete the following procedures:

1. Make certain both end covers are secured to the unit.
2. Measure and cut the pressure sensitive gaskets to the correct lengths and attach to the flanges.
3. Starting at a corner, attach the top flange with the metal cutting screws provided.
4. Press the corner transition pieces onto the end of the flange and attach the adjoining flanges and filler pieces at the bottom of the unit. Work around the unit in this manner until all flanges and corners are installed.
5. Mounting holes are pre-drilled in the flanges. Use the assembled flanges as a template to drill all 7/32" mounting holes in the cabinet.
6. Attach the flange section to the unit cabinet with the mounting screws provided.
7. Open and remove the front access panel.
8. Set the unit in place and push it tightly against the back support and flush with the wall surface. Anchor the unit to back supports, using the 1/2" mounting holes described in the **Unit Mounting** section.
9. Tighten the mounting fastener, making sure that the unit is level.

**Figure 19:** Recess flange installation for vertical unit ventilators

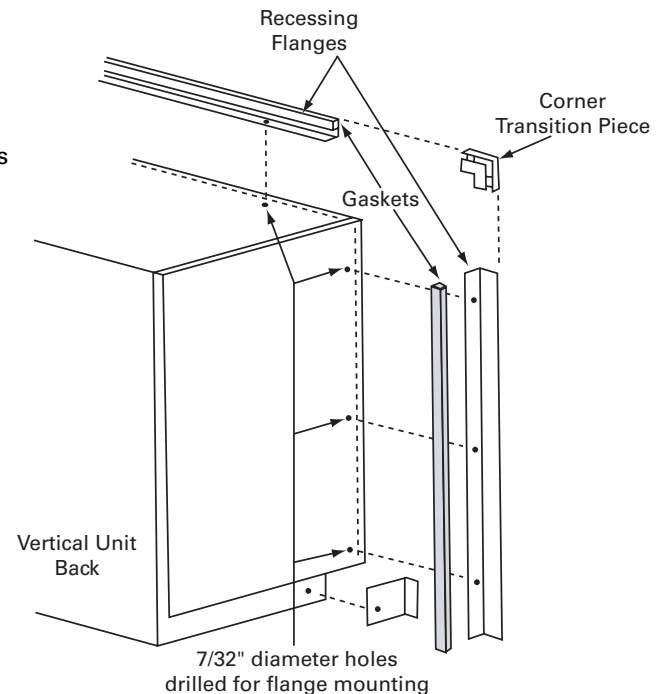

**NOTE:** Unit must be mounted level. Coils and drain pans inside the unit are pitched properly for drainage before shipment.

### End Covers

When ordered as an option, end covers ship already attached to the vertical unit ventilator. The following section is for installing end covers purchased as an add-on.

It is recommended end panels be installed on the unit ventilator after all piping, wiring and accessory installation is completed.

To install the end panel:

1. Insert the four factory provided metal studs into the four pre-mounted nuts on the inside of the panel.

2. Align each stud with the four pre-drilled holes on the side of the unit.
3. Secure the panel to the unit by fastening with the four factory provided nuts.
4. Do not over-tighten screws.

### CAUTION

#### Equipment Damage

Do not run units for any length of time without all panels and filters properly installed. Failure to do so may result in equipment failure.

# Installation

## Horizontal Unit Ventilator

The horizontal unit ventilator may be attached directly to the ceiling or suspended from the ceiling by hangers. Hanger rods should be at least 3/8" diameter steel to support unit weight, as given in **Table 5**.

### **WARNING** **Heavy Objects!**

*Always lift unit with fork trucks or other special lifting device following the recommended procedures. Failure to properly lift the unit as instructed, could result in death or serious injury.*

Install the hanging devices before hoisting the unit. A fork lift or other special lifting device is required to hoist the unit into mounting position.

Protect the unit finish by covering the lifting platform.

To hoist the unit into place, follow the instructions below:

1. Secure 2 x 4's to the lift forks as shown in Figure 19. These two supports must be long enough and spaced properly on the forks to support the unit while it is being lifted and clear the duct flanges on the unit.
2. Tip the unit onto the supports and slide it toward the lift until the unit weight balances.
3. Lift the unit. Once in position, temporarily secure the unit to the hanger rods or mounting studs with nuts and washers.
4. Align the unit with the duct work. When in proper alignment, tighten the mounting nuts securely.
5. Recheck the unit alignment and make sure the unit is level.
6. Replace all covers, panels and filters before starting the unit.

**Figure 20:** Preparing the horizontal classroom ventilator for lifting and installation.

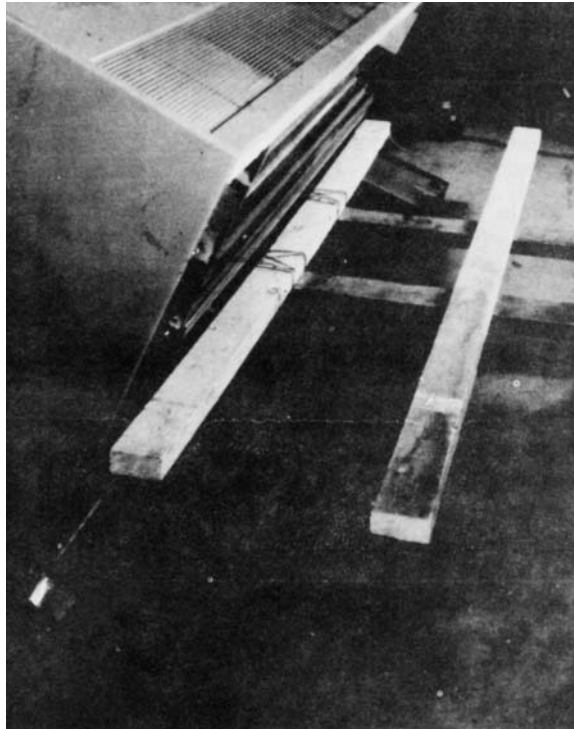

# Installation

## Horizontal Recessed Mounting

The recessing flange assembly includes pre-cut flanges, corner transition pieces, mounting screws, filler pieces and pressure sensitive gaskets. Refer to **Figures 21 & 22** for typical horizontal installation

1. Measure and cut the pressure sensitive gaskets to the correct lengths and attach to the flanges.
2. Starting at a corner, attach the top flange with the metal cutting screws provided.
3. Press the corner transition pieces onto the end of the flange and attach the adjoining flanges and filler pieces at the bottom of the unit. Work around the unit in this manner until all flanges and corners are installed.
4. Mounting holes are pre-drilled in the flanges. Use the assembled flanges as a template to drill all 7/32" mounting holes in the cabinet.
5. Attach the flange section to the unit cabinet with the mounting screws provided.
6. Open and remove the front access panel.
7. Tighten the mounting fastener, making sure that the unit is level.
8. Open the unit access panel and remove the bottom front panel. See Figure 23.
9. Hoist the unit onto a forklift and mount in place as described in the **Unit Mounting** section, ensuring the unit is secured and aligned in place, and that the mounting nuts are tightly fastened.  
**NOTE:** Unit must be mounted level. Coils and drain pans inside the unit are pitched internally for proper drainage.
10. Replace all covers, panels and filters before starting the unit.

**Figure 21:** Recess flange installation around horizontal unit ventilator access panel and inlet

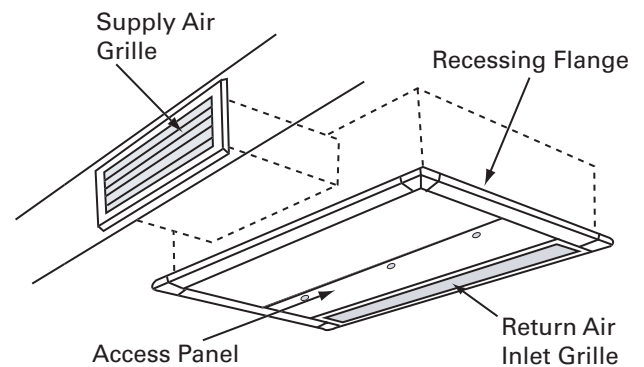

**Figure 22:** Recess flange installation around bottom and front of horizontal unit.

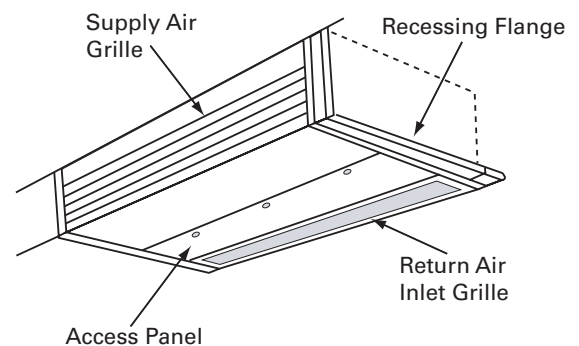

**Figure 23:** Horizontal unit ventilator with front panel removed

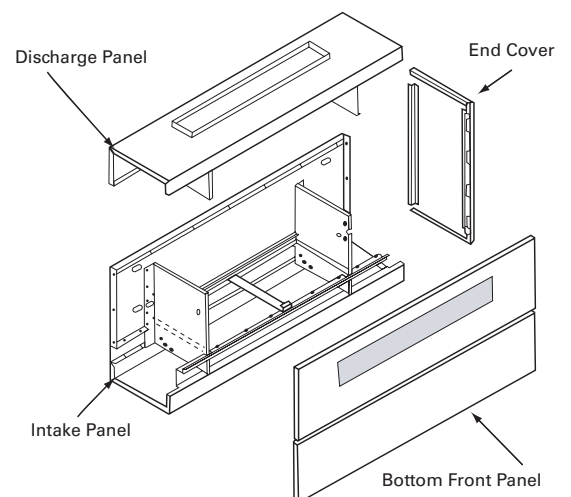

# Installation

## Piping Installation

**NOTE:** Before installation of piping package, the shipping bracket holding the piping in place, must be removed.

Proper installation of piping is necessary to provide efficient coil operation and to prevent damage during operation. Follow standard piping practices and include all accessories as necessary.

Piping connection knockouts are shown in Figures 6 through 14. Field connection types and sizes for units without piping packages are listed in **Table 7**.

A 3/4" OD condensate drain connection is provided on the chilled water supply end of the unit. **Figure 24** shows the vertical unit connection. Attach a flexible condensate drain hose over the drain pan connection and secure with a hose clamp.

The drain pan on the vertical is vacuum molded with a drain connection at each end. The cooling side connection is cut at the factory.

To field reverse the slope of a vertical

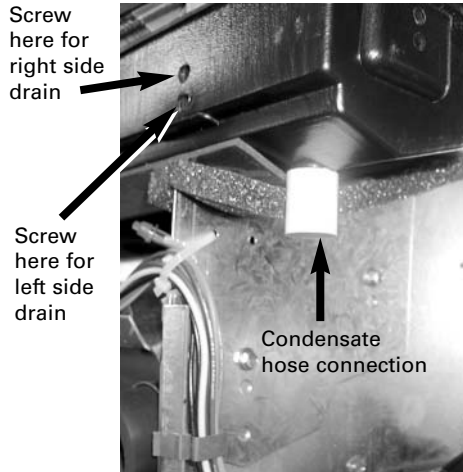

**Figure 24:** Drain pan connection. Field install a flexible hose for condensate drainage.

unit drain pan, plug the factory cut connection on the other side. Then reverse the screws on each corner of the drain pan. *Example:* To drain to the right, put the right-hand drain screw in the top hole and the left-hand screw in the bottom hole. (See Figure 24).

The drain pan on the horizontal unit is internally pitched. To field reverse,

remove the screws and drain pan, rotate the pan and reinstall.

After the condensate drain piping has been completed, check water flow to be sure the system properly carries and away all condensate accumulation.

A P-trap is recommended for installations that drain directly into a sewer system. A P-trap is not necessary for operation but will eliminate sewer gas odor.

## Trane Piping Packages (Option)

Trane Standard Piping Package includes a 2-way or 3-way valve with bypass balance valve, ball valves, Pete's plugs and unions. A strainer and circuit balancing valve are optional.

All union connections should be tightened in the field. Units are shipped with union connections hand tightened only in the factory.

**NOTE:** All connections made in the field should be sweat connections.

**NOTE:** Piping packages are not shipped insulated. Any insulation should be provided in the field by the installing contractor.

**Table 7:** Coil Data

Coil	Description	Connection Location	Field Coil Connection
A	2-pipe chilled water/Hot water	Left or Right	7/8" OD male sweat
H	Hot water only	Left or Right	7/8" OD male sweat
D	4-pipe chilled water/Hot water	Left or Right (opposite ends)	7/8" or 5/8" OD male sweat
X	Chilled water/Electric heat	Left hand cooling/Right hand heat	7/8" OD male sweat
K1, 2	Steam	Left or Right	1" MPT
DK	Chilled water/Steam	Left or Right	7/8" OD/ 1" MPT
R	2-pipe chilled water/Reheat hot water	Left or Right	7/8" or 5/8" OD male sweat
E	Electric heat only	Right hand heat	NA
F0	DX only	Left hand cooling	7/8" suction, 3/8" discharge
FA	DX/hot water	Left hand cooling/Right hand heat	7/8" suction, 3/8" discharge/ 5/8" OD Male sweat
FK	DX/Steam	Left hand cooling/Right hand heat	7/8" suction, 3/8" discharge/ 1" MPT
F3, 4, 6	DX/Electric heat	Left hand cooling/Right hand heat	7/8" suction, 3/8" discharge/NA

**Notes:**

1. Supply and return connections are located on the same end of each coil.
2. All Trane piping packages have union connections; all units with piping packages by others have sweat connections.
3. Coil connections are sweat except steam coils, which are threaded

# Installation

## Installation Crossover Piping

Crossover piping is available for A, D and H coils. It is either 1 3/8" [34.9] or 2 1/8" [54] in diameter (O.D.) as specified by the customer. Crossover piping can be found in either the left or right hand end pocket. See Figure 26.

On D style coils, crossover piping connects to the main cooling coil.

Factory insulation is provided on all crossovers.

When a Trane piping package is ordered, it is installed with the connections made to the supply and return of both the coil and the crossover piping. However, supply and return connections must be made in the field when a piping package is furnished by the installer.

The crossover piping is located at the back of the unit along the wall and the ends of the piping are flush with the end of the unit.

Expansion compensation between the piping package and the crossover piping is achieved using flex hoses rated at 250 psi working pressure. Expansion compensation for the crossover piping must be handled external to the unit ventilator.

**Figure 25:** Condensate drain pan dimensions and screw location.

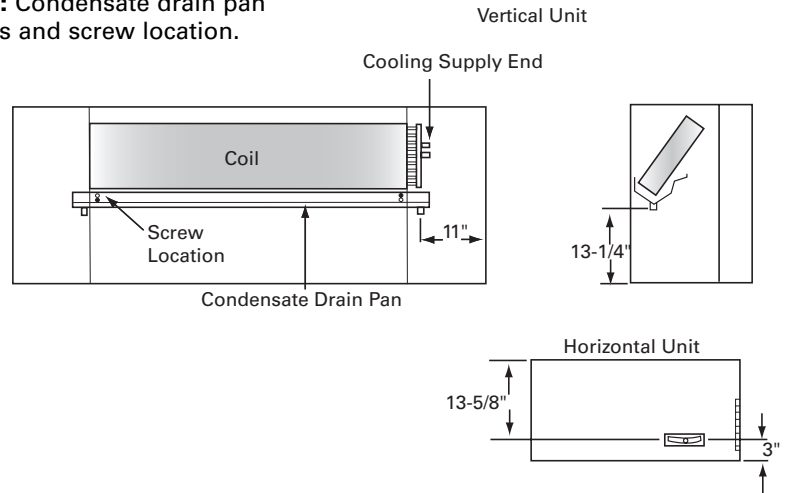

**Figure 26:** Typical crossover piping

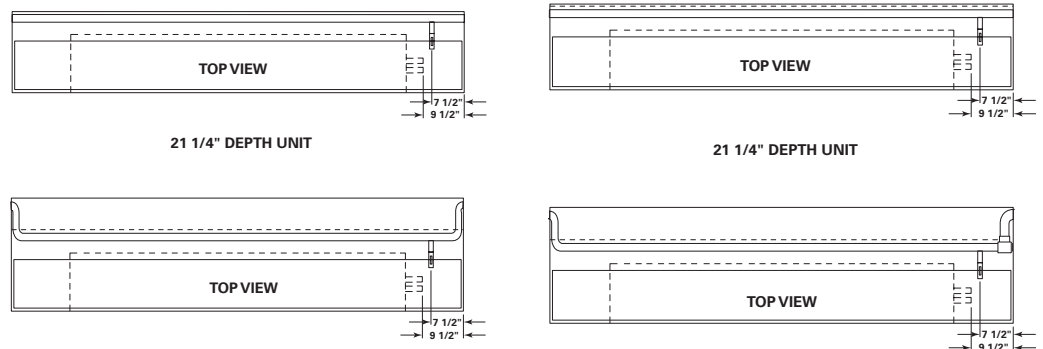
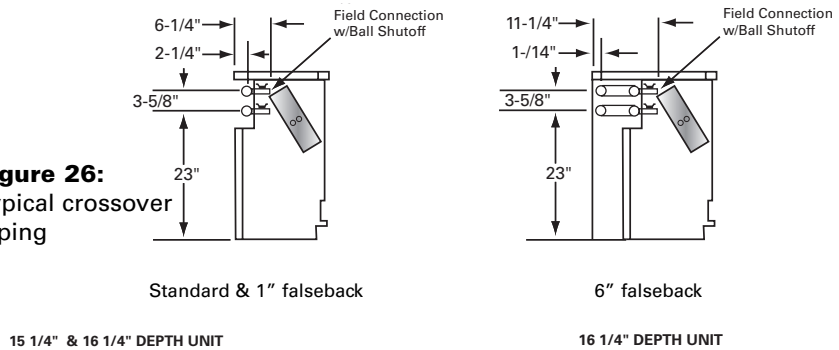

CROSSOVER PIPING IS AVAILABLE FOR A, H AND D COILS. FOR ALL D (4-PIPE) COILS, TRANE PROVIDES THE CROSSOVER FOR THE COLD WATER ONLY. THE CROSSOVER PIPE IS FACTORY INSULATED WITH 3/8" THICK INSULATION.

EXPANSION COMPENSATION BETWEEN THE FACTORY PIPING PACKAGE AND THE CROSSOVER PIPING IS ACHIEVED USING A FLEX HOSE RATED AT 250 PSI WORKING PRESSURE. FLEX HOSE IS ONLY AVAILABLE WITH FACTORY MOUNTED PIPING PACKAGES.

EXPANSION COMPENSATION FOR THE CROSSOVER PIPING MUST BE HANDLED EXTERNAL TO THE UNIT VENTILATOR.

CROSSOVER CONNECTIONS TERMINATE IN THE SAME END POCKET AS THE MAIN COIL CONNECTION. THE MAIN COIL CONNECTION FOR 2-PIPE SYSTEMS IS THE HEATING COIL. THE MAIN COIL CONNECTION



# Installation

## Split System Units

The following refrigerant piping and interconnecting wiring instructions apply to unit ventilators with direct expansion type cooling coils used in conjunction with air-cooled condensing units. Reference must also be made to the condensing unit installation and wiring manuals which are shipped with the condensing unit.

**NOTE:** A UL listing mark applied to a unit ventilator does not apply to any associated refrigerant condensing unit.

## Refrigerant Piping

Unit ventilators with direct expansion cooling contain a nitrogen holding charge in the evaporator coils. Connections are “pinched off” at the factory.

To connect the condensing unit lines, cut off the stubouts and swage. The condensing unit lines can then be brought into the swage and brazed. Trane recommends the use of nitrogen purge when brazing refrigerant lines to prevent formation of oxides in the lines.

Install the refrigerant suction and liquid lines as described in the condensing

unit installation instructions. The TXV is factory installed on the Unit Ventilator. Piping should be run straight out through the back of the unit. Access piping knockouts are located in the rear panels of the unit, as shown in **Figures 6 through 14.**

Recommended refrigerant line connections for various unit combinations are given in **Table 10.** Typical Superheat Charging Charts are shown in the Trane Service Facts found in the condensing unit section manual. Refrigerant charge weights can also be determined with your local Trane sales engineer using a valid Trane Selection Program.

**Table 10:** Refrigerant Line Sizes (TTB, TTA, 2TTA & TTP Condensing Units)

Unit Size	Condensing Unit	UV Connection Size	Condensing Unit Connection Size	Liquid Line Size	Suction Line Size
075	TTB, TTP	Liquid - 3/8" Suction - 7/8"	Liquid - 3/8" Suction - 7/8"	3/8" OD	7/8" OD
100	TTP, TTB, TTA, 2TTA	Liquid - 3/8" Suction - 7/8"	Liquid - 3/8" Suction - 7/8"	3/8" OD	7/8" OD
125	TTB, TTA, 2TTA	Liquid - 3/8" Suction - 7/8"	Liquid - 3/8" Suction - 7/8"	3/8" OD	7/8" OD
150	2TTA, TTB, TTA	Liquid - 3/8" Suction - 7/8"	Liquid - 3/8" Suction - 7/8"	3/8" OD	7/8" OD
200	TTA, 2TTA	Liquid - 3/8" Suction - 7/8"	Liquid - 3/8" Suction - 7/8"	3/8" OD	7/8" OD

**Notes:**

1. Refrigerant connections sweat and “pinched-off” at the factory
2. All DX Unit Ventilators are shipped with a Nitrogen holding charge.

# Installation

## Steam Piping

When air, water or another product is heated, the temperature or heat transfer rate can be regulated by a modulating steam pressure control valve. Since pressure and temperature do not vary at the same rate as load, the steam trap capacity, which is determined by the pressure differential between the trap inlet and outlet, may be adequate at full load, but not some lesser load.

There are detailed methods for determining condensate load under various operating conditions. However, in most cases this is not necessary if the coils are piped as shown in **Figure 27**. Follow the procedure documented in the ASHRAE Systems Handbook, Steam Systems.

**Figure 27:** Steam Piping

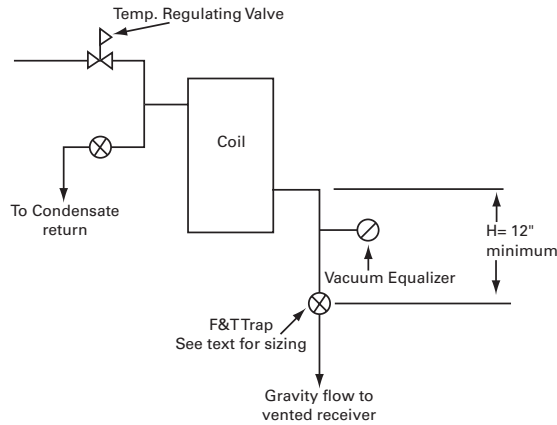

## Modulating Water Valves

(Option) The actuator on the valve is a 24V, 3-point floating valve. The actuator can be easily removed from the valve body by pressing in on the locking tab and rotating the actuator 45° counterclockwise (See Figure 28a). The 2-way valves are bi-directional flow. The 3-way valves can be mixing or diverting (See Figure 28b).

**NOTE:** The actuator must be removed if soldering is being conducted near the valve. High heat may cause damage to the actuator's plastic body/mechanisms.

On applications without factory installed piping packages (Option), it is important to remove the cartridge assembly from the valve body with the provided tool (Figure 29).

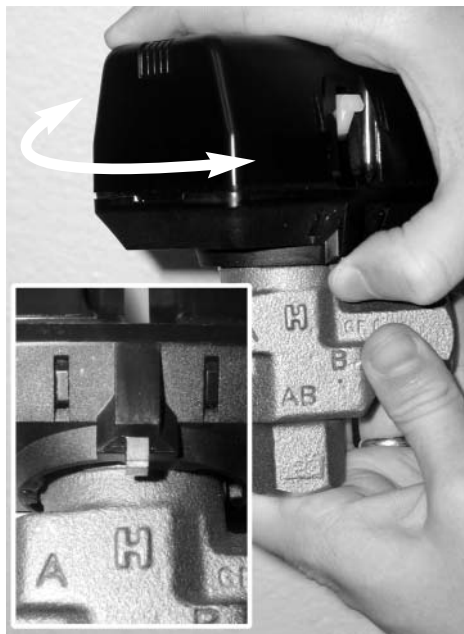

**Figure 28a:** Remove modulating valve actuator by pressing in tab (inset) and turning actuator 45° counterclockwise.

**Figure 28b:** Steam Piping

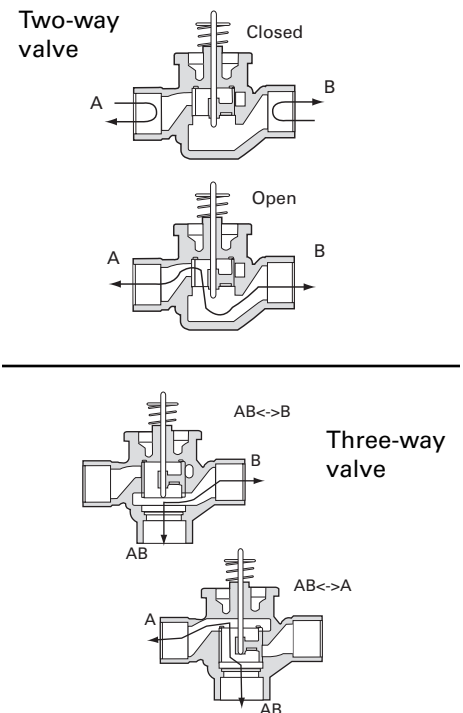

# Installation

**Figure 29:** Cartridge removal tool

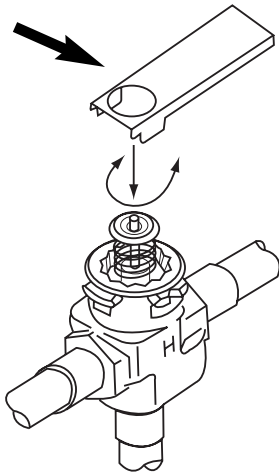

Use the following steps to complete cartridge assembly removal:

1. Remove valve actuator.
2. Remove the cartridge assembly from the valve body with the enclosed tool.
3. Solder the valve in accordance with normal soldering practices.
4. Re-install the cartridge after soldering by tightening until it bottoms out. The top surface of the cartridge will be flush with the top edge of the body casting. **NOTE: Do not over-tighten. Maximum torque is 40 in-lb.**
5. Replace valve actuator and wire in accordance with instructions.

## Plumbing

The valve may be plumbed in any angle but preferably not with the actuator below horizontal level of the body. Make sure there is enough room around the actuator for servicing or replacement.

For use in diverting applications, the valve is installed with the flow water entering through the bottom AB port

and diverting through end ports A or B. In mixing applications the valve is installed with inlet to A or B and outlet through AB.

Mount directly to the tube or pipe. Do not grip the actuator while making or tightening plumbing connections. Either hold valve body by hand or attach an adjustable spanner (38mm/1-1/2") across the hexagonal or flat faces on the valve body (See Figure 30).

**Figure 30:** Proper plumbing technique for modulating valves.

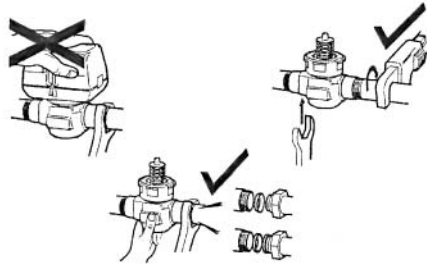

## Manual Opener

The manual opener can be manipulated only when in the up position. The A port can be manually opened by firmly pushing the white manual lever down to the midway position and pushing the lever in. In this position, both A and B ports are open. This "manual open" position may be used for filling, venting and draining the system or opening the valve during power failure.

The valve can be closed by depressing the white lever lightly and then pulling the lever outward. The valve and actuator will return to the automatic position when power is restored. **NOTE: If the valve is powered open, it cannot be manually closed, unless the actuator is removed.**

## Wiring

A controller and a separate transformer is required to operate each valve (See Figures 31 & 32). Port A "open" and "closed" denote valve open and closed positions.

**Figure 31:** Wiring for modulating valve actuator

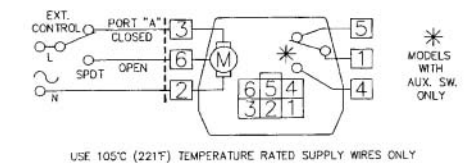

**Figure 32:** Wiring for modulating valve actuator

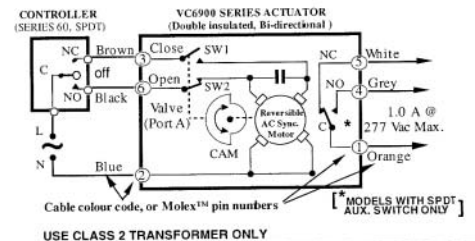

The typical floating controller is an SPDT controller with a center-off position. On a change in temperature from the set point, the controller will close the NO or NC contacts, driving the valve to an intermediate position until a further change at the controller.

The valve is set between the limits of the controller to satisfy various load requirements. In the event of power failure, the valve will stay in the position it was in before loss of power. When power is restored, the valve will again respond to controller demand.

# Installation

## Isolation Valves Installation

The valve can be mounted in any position on a vertical line. If the valve is mounted horizontally, the actuator must be even with or above the center line. Make sure there is enough room to remove actuator cover for servicing. Mount the valve on the tube or pipe. **NOTE:** Make sure the flow through the valve is in the direction indicated by the arrow stamped on the valve body.

**Figure 33:** Proper mounting for isolation valves

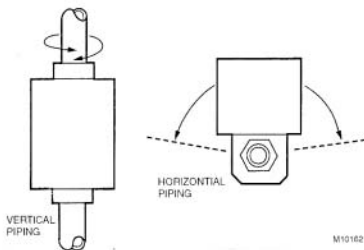

## Servicing/Removal of valves

The actuator can be removed from the valve body. Removing the actuator is recommended of soldering is being conducted near the valve. To remove the actuator:

1. Place the manual operating lever to the Open position (See Figure 34)
2. Depress the locking button and lift actuator until it separates from the valve body.

**Figure 34:** Removing isolation valve actuator

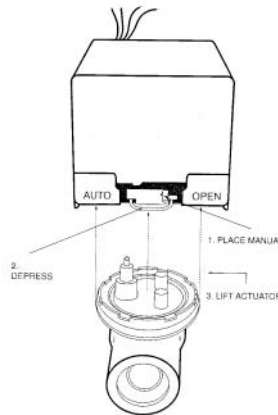

To install the actuator to the valve body:

1. Align the slot on the shaft of the valve with the valve body notch on side of body (See Figure 35)

**Figure 35:** Installing isolation valve actuator

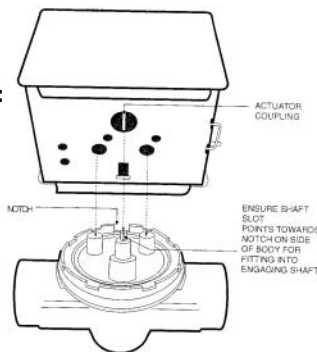

2. Install body valve into pipe.
3. Wiring connections may be made either before or after actuator is stalled on body.
4. Place the manual operating lever on the actuator in the OPEN position.
5. Align actuator coupling to slot on the shaft of the valve body and fit the head onto the valve body to ensure the shaft seats correctly (Figure 35).

6. Press the actuator and valve body until it secures together.

Soldering procedures are as follows:

1. Remove actuator as stated earlier
2. Place valves on the pipe. Rotate valve stem so the shaft slot points at the notch in the side of the body (90° to flow direction). This protects the plug inside the valve by removing it from the seat. (See Figure 36)
3. Sweat the joints, keeping outer surface free from solder. **NOTE:** Do not use silver solder due to high temperature requirements.

**Figure 36:** Preparation for soldering

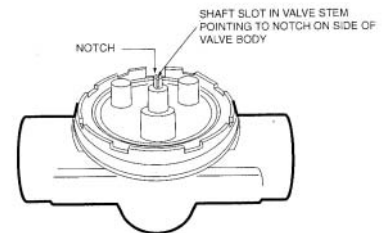

# Installation

## Heating Coils with Direct Expansion Cooling

Heating options for direct expansion cooling in the unit ventilator are hot water, steam or electric heat.

These coils facilitate direct expansion cooling with standard capacities. The supply and return connections are located in the right hand end pocket. Hot water field connections are made with a 5/8" \[15.9\] OD male sweated joint, while steam coils have a 1" \[25.4\] male pipe thread (MPT) connection (**Table 5**).

Electric heat coils provide a third way to supply heating to the direct expansion cooling. The coil utilizes three to six preheat elements which are factory wired.

## Wiring

### **WARNING** **Hazardous Voltage!**

*Disconnect all electric power, including remote disconnects before servicing. Follow proper lockout/tagout procedures to ensure the power can not be inadvertently energized. Failure to disconnect power before servicing could result in death or serious injury.*

A typical unit ventilator with DX coil includes an outside air thermostat, a frost prevention thermostat and a 24V transformer for condensing unit control.

Wire sizing is the same as given for the thermostat wiring in the condensing unit installation instructions, or may be obtained from the nameplate. The condensing unit must be controlled by the same room thermostat that also controls the Unit Ventilator.

## Split System Start-Up

After all piping and wiring has been completed, follow the instructions provided with the condensing unit for control testing and system start-up. If sweat type field-piped systems are being used, then pressure testing, evacuation and refrigerant charging will be required.

Two bulbs will also be shipped with a split system unit:

1. Frost stat bulb
2. TXV valve.

Both components are to be field installed using the installation kit shipped with the unit. For complete installation instructions and locations, refer to the tag attached to the installation kit within the unit. See Figure 37 for an example of the installation tag.

**NOTE:** *Depending on the controls package ordered with the unit, not all installations will require mounting the frost stat bulb.*

**Figure 37:** Frost stat/TXV valve installation tag

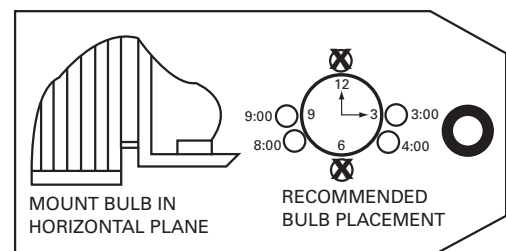
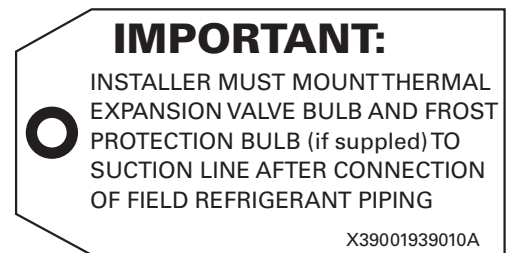

# Installation

## Wiring

All classroom unit ventilators have 115V motor power. Motor data can be found in **Tables 9 and 10**:

**Table 9:** UV Standard Motor Data\*

Unit Size	Volts	RPM	CFM	Amps	Watts	HP
075	115/60/1	1075	750	2.3	222	1/6
100	115/60/1	1075	1000	2.3	222	1/6
125	115/60/1	1075	1250	2.6	287	1/4
150	115/60/1	1075	1500	2.6	287	1/4
200	115/60/1	940	2000	5.7	639	1/3

\* Data typical for AA Coil

**Table 10:** Hi-ESP Motor Data\*

Unit Size	Volts	RPM	CFM	Amps	Watts	HP
075	115/60/1	1360	750	4.8	597	1/3
100	115/60/1	1360	1000	4.8	597	1/3
125	115/60/1	1410	1250	7.0	844	1/2
150	115/60/1	1410	1500	7.0	844	1/2
200	115/60/1	1140	2000	8.1	936	3/4

\* Data typical for AA Coil

## Control Power

### CAUTION

#### Control Power Wiring

*Wiring diagrams given in this manual are typical. Actual wiring for particular units may differ. To prevent damage to the unit, refer to the diagram provided on the unit for specific wiring information.*

Unit ventilator controls and control wiring can be factory mounted or field installed.

Wiring diagrams (**Figures 38 and 41**) illustrate the standard unit motors with one and two speed control. Terminal wiring is provided by Trane and the actual components used for a particular installation may differ. Control and line diagrams for the exact control system used are provided with each unit.

**CAUTION:** *When installing field provided controls, do not alter or remove any built-in unit safeties. Tampering with unit safeties may cause unit overheating and possible fire hazard.*

**CAUTION:** *Do not remove or alter the wiring of the Time Delay Relay (DL). Doing so may result in premature motor failures.*

## Supply Power

### CAUTION

#### Use Copper Conductors Only!

*Unit terminals are not designed to accept other types of conductors. Failure to use copper conductors may result in equipment damage.*

Power supply wiring is to be connected to terminals 1 and 2 at the junction box in the left end pocket, below the discharge air grille.

## Electric Heat

### Supply Power

Supply power wiring is to be connected to the following line terminals in the right hand end pocket:

- 208V or 240V, 3-phase, 3 wire system: L1, L2 and L3. (See **Figure 42**)
- 480V, 3-phase, 4 wire system: L1, L2, L3 and N (neutral)  
See **Figure 43**.
- See Figure 44 for a typical unit line and interconnecting wiring diagram for Electric Heat Coils.  
**NOTE:** *480 V/3-Wire is NOT compatible with Trane Classroom Unit Ventilator equipment. There must be a 4-Wire system with a separate ground.*

**NOTE:** *The supply neutral wire must be connected to the neutral terminal block.*

Operational controls and electric heating safety devices are factory mounted. These devices are: high temp cut outs and panel interlock, both of which de-energize electric heating elements through the K1 safety contactor.

# Wiring Diagrams

**Figure 38:** Field Installed Controls, 120V, 1 Speed Unit Mounted Fan Switch

<b>⚠ WARNING</b>	<b>⚠ AVERTISSEMENT</b>
HAZARDOUS VOLTAGE DISCONNECT ALL ELECTRIC POWER INCLUDING REMOTE DISCONNECTS BEFORE SERVICING. FAILURE TO DISCONNECT POWER BEFORE SERVICING CAN CAUSE SEVERE PERSONAL INJURY OR DEATH.	VOLTAGE DANGEREUX DECONNECTEZ TOUTES LES SOURCES ELECTRIQUES INCLUANT LES DISCONNECTS RELOUES A DISTANCE AVANT D'EXECUTER LE TRAVAIL ELECTRIQUE AVANT D'EXECUTER LE TRAVAIL ELECTRIQUE PEUT ENRANGER DES BLESSURES CORPORELLES SEVERES OU LA MORT.
<b>IMPORTANT</b>	
USE COPPER CONDUCTORS ONLY TO PREVENT EQUIPMENT DAMAGE. UNIT TERMINALS ARE NOT DESIGNED TO ACCEPT ANY OTHER WIRING.	

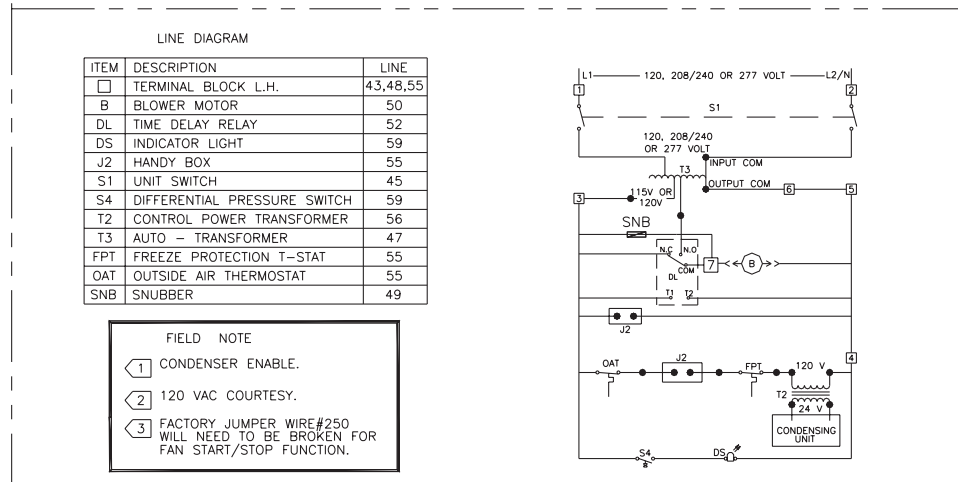
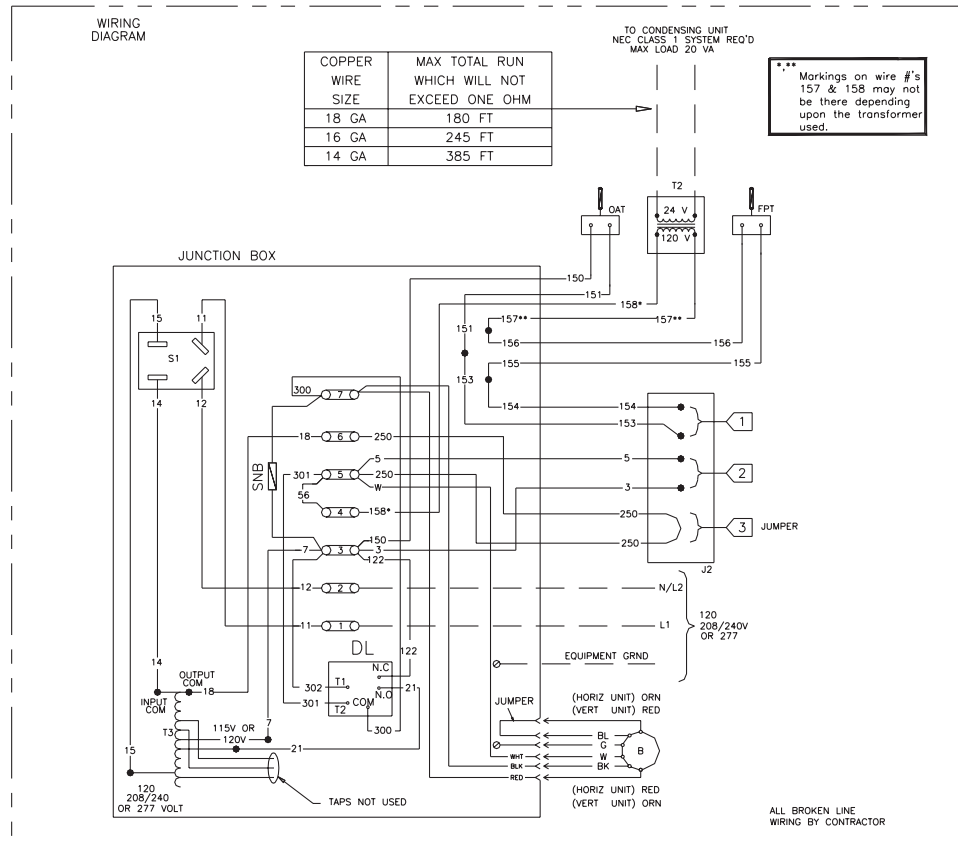



# Wiring Diagram

**Figure 40:** Field Installed Controls, Horizontal UV, 120V, 1 Speed Wall Mounted Fan Switch

**⚠ WARNING** HAZARDOUS VOLTAGE. DISCONNECT ALL ELECTRIC POWER INCLUDING REMOTE DISCONNECTS BEFORE SERVICING. FAILURE TO DISCONNECT POWER BEFORE SERVICING CAN CAUSE SEVERE PERSONAL INJURY OR DEATH.

**⚠ AVERTISSEMENT** VOLTAGE, HAZARDEUX. DÉCONNECTEZ TOUTES LES SOURCES ÉLECTRIQUES INCLUANT LES DISCONNECTEURS SITES À DISTANCE AVANT D'EFFECTUER L'ENTRETIEN ÉLECTRIQUE. ÉCHEC À EFFECTUER LA SOURCE ÉLECTRIQUE AVANT D'EFFECTUER L'ENTRETIEN PEUT ENTRAÎNER DES BLESSURES CORPORELLES SÈVÈRES OU LA MORT.

**IMPORTANT**  
USE COPPER CONDUCTORS ONLY TO PREVENT EQUIPMENT DAMAGE. UNIT TERMINALS ARE NOT DESIGNED TO ACCEPT ANY OTHER WIRING.

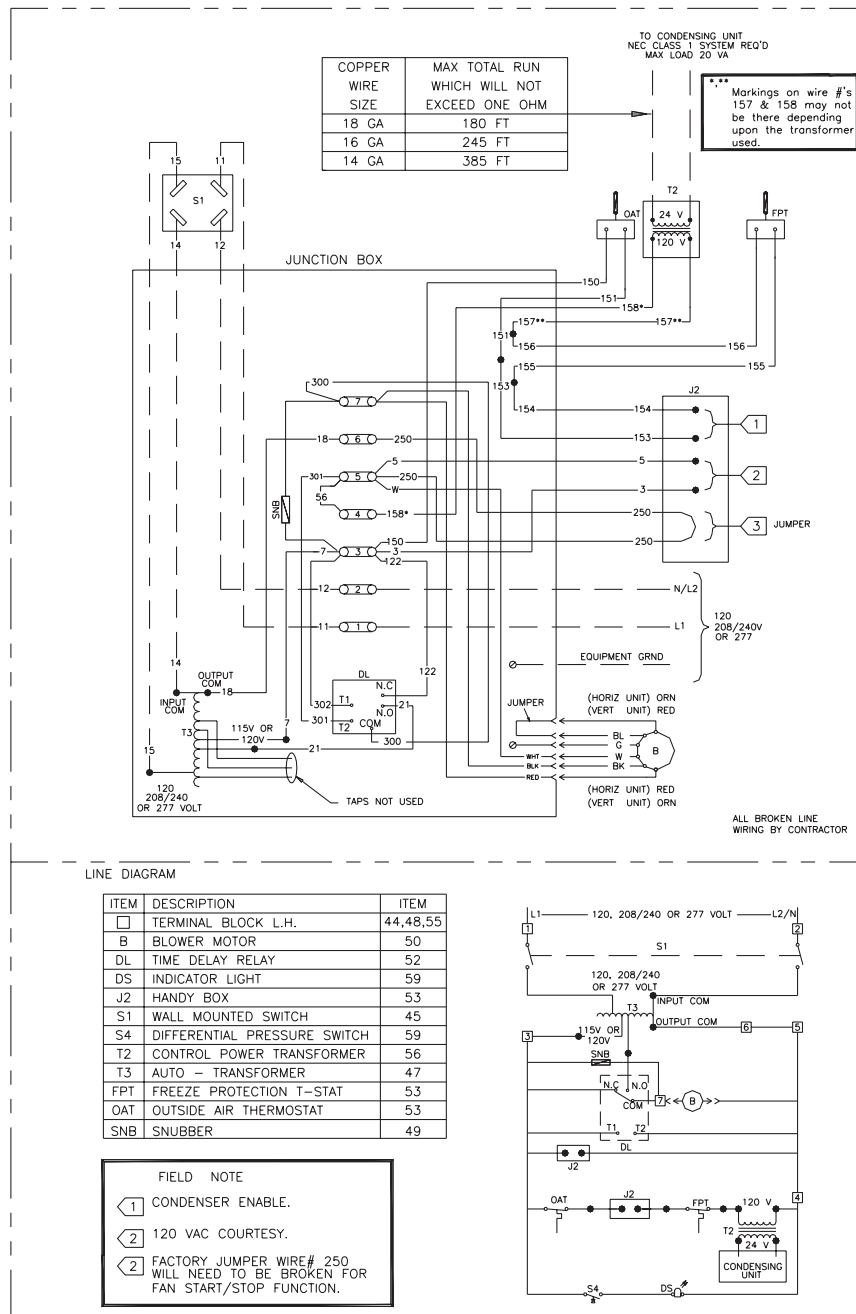

**LINE DIAGRAM**

ITEM	DESCRIPTION	ITEM
□	TERMINAL BLOCK L.H.	44,48,55
B	BLOWER MOTOR	50
DL	TIME DELAY RELAY	52
DS	INDICATOR LIGHT	59
J2	HANDY BOX	53
S1	WALL MOUNTED SWITCH	45
S4	DIFFERENTIAL PRESSURE SWITCH	59
T2	CONTROL POWER TRANSFORMER	56
T3	AUTO - TRANSFORMER	47
FPT	FREEZE PROTECTION T-STAT	53
OAT	OUTSIDE AIR THERMOSTAT	53
SNB	SNUBBER	49

**FIELD NOTE**

① CONDENSER ENABLE.

② 120 VAC COURTESY.

③ FACTORY JUMPER WIRE# 250 WILL NEED TO BE BROKEN FOR FAN START/STOP FUNCTION.

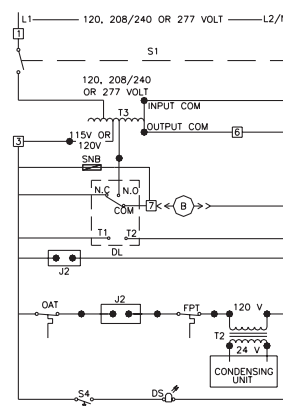

# Wiring Diagram

**Figure 41:** Field Installed Controls, Horizontal UV, 120V, 2 Speed Wall Mounted Fan Switch

**⚠ WARNING** **⚠ AVERTISSEMENT**  
 HAZARDOUS VOLTAGE VOLTAGE HAZARDEUSE  
 DISCONNECT ALL ELECTRIC POWER INCLUDING REMOTE DISCONNECTS BEFORE SERVICING. DÉCONNECTEZ TOUTES LES SOURCES ÉLECTRIQUES INCLUANT LES DISJONCTEURS SÉPARÉS À DISTANCE AVANT D'EFFECTUER L'ENTRETIEN.  
 FAILURE TO DISCONNECT POWER BEFORE SERVICING CAN CAUSE SEVERE PERSONAL INJURY OR DEATH. ÉCHÉC À DÉCONNECTER LA SOURCE ÉLECTRIQUE AVANT D'EFFECTUER L'ENTRETIEN PEUT ENTRAÎNER DES BLESSURES CORPORELLES SÉVÈRES OU LA MORT.

**IMPORTANT**  
 USE COPPER CONDUCTORS ONLY TO PREVENT EQUIPMENT DAMAGE. UNIT TERMINALS ARE NOT DESIGNED TO ACCEPT ANY OTHER WIRING.

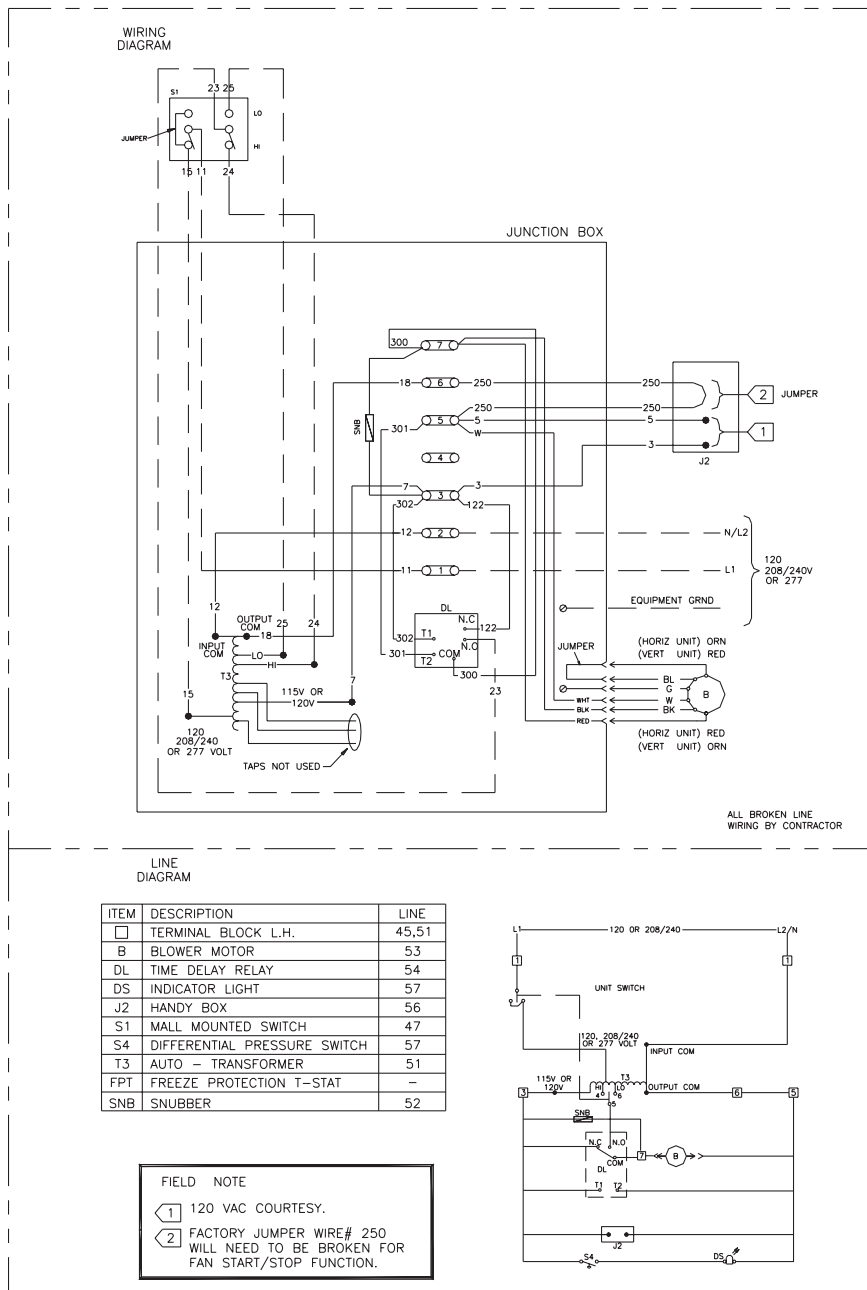

# Wiring Diagrams

**Figure 42:** Power Diagram For 208V or 240V, 3-Phase, 3-Wire Electric Heat

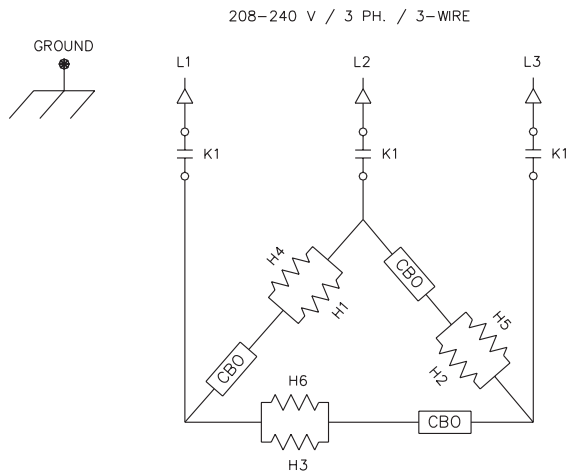
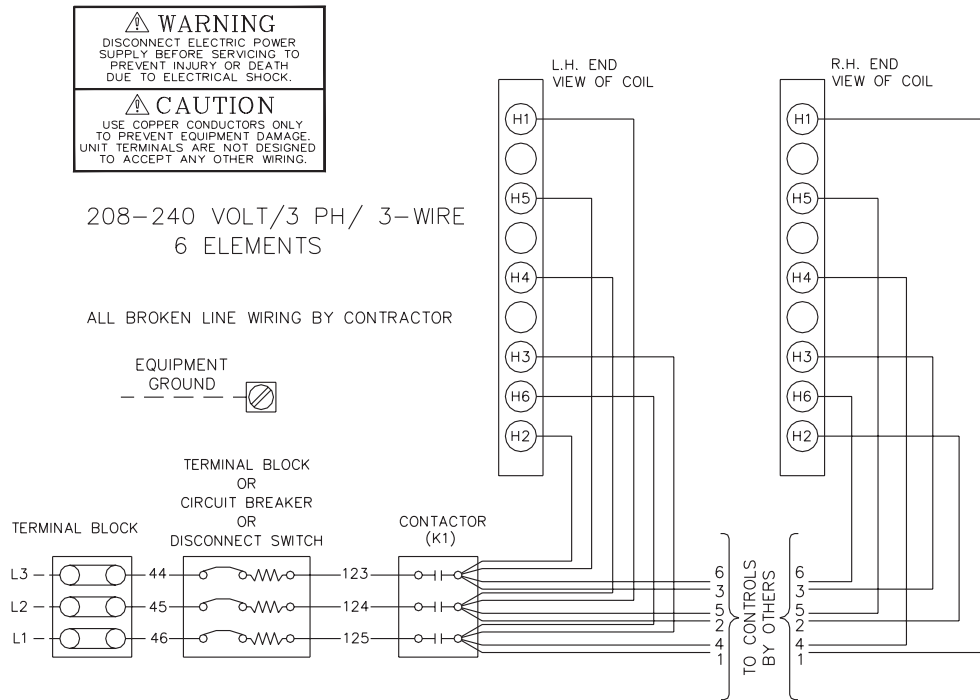

# Wiring Diagram

**Figure 43:** Power Diagram For 480V, 3-Phase, 4-Wire Electric Heat

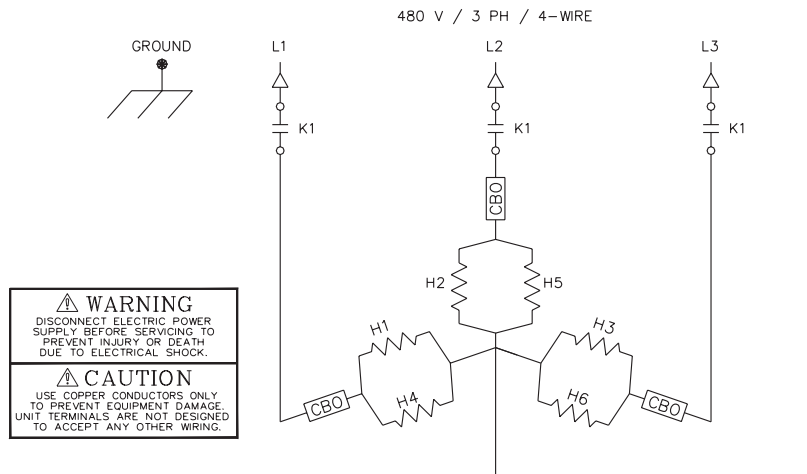
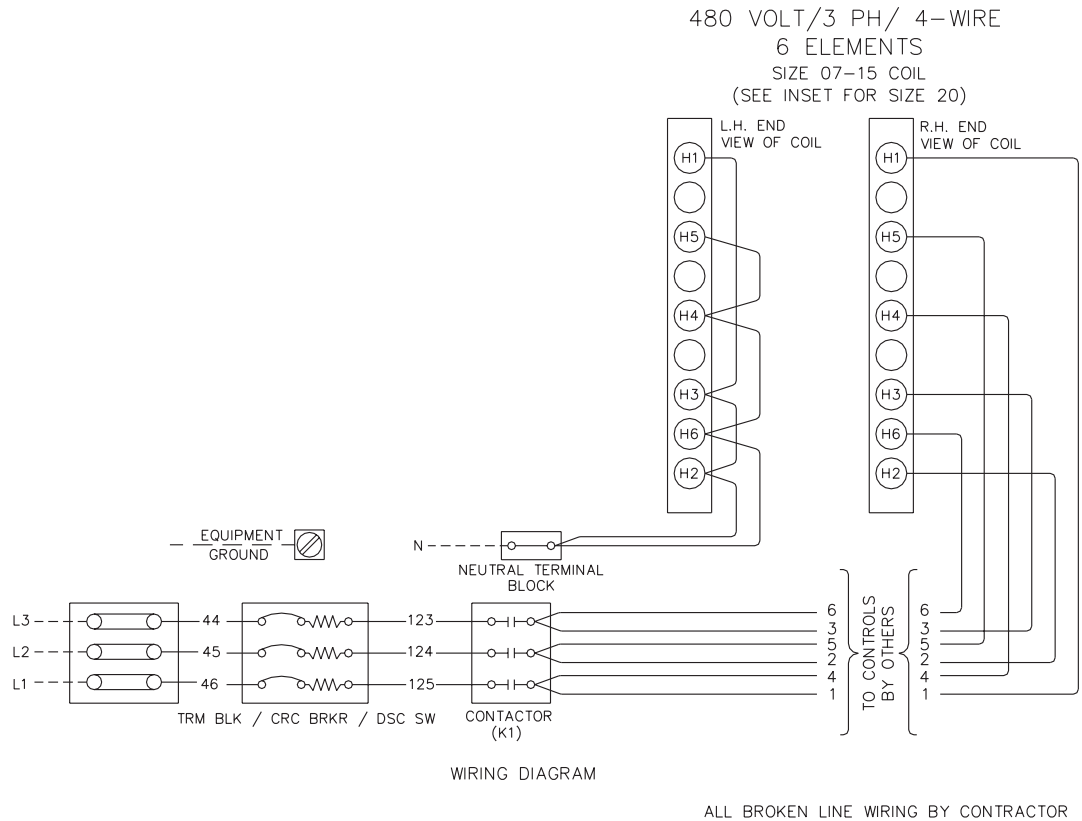

**NOTE:** Important! Incoming power to the unit ventilator is 3-phase, 4-wire for a 480-volt system. The system contains 5 conductors: 3-hot, 1-neutral and 1-equipment ground. The neutral line **can not** be used as the equipment ground.

# Wiring Diagrams

**Figure 44: Power Diagram For 480V, 3-Phase, 4-Wire Electric Heat**

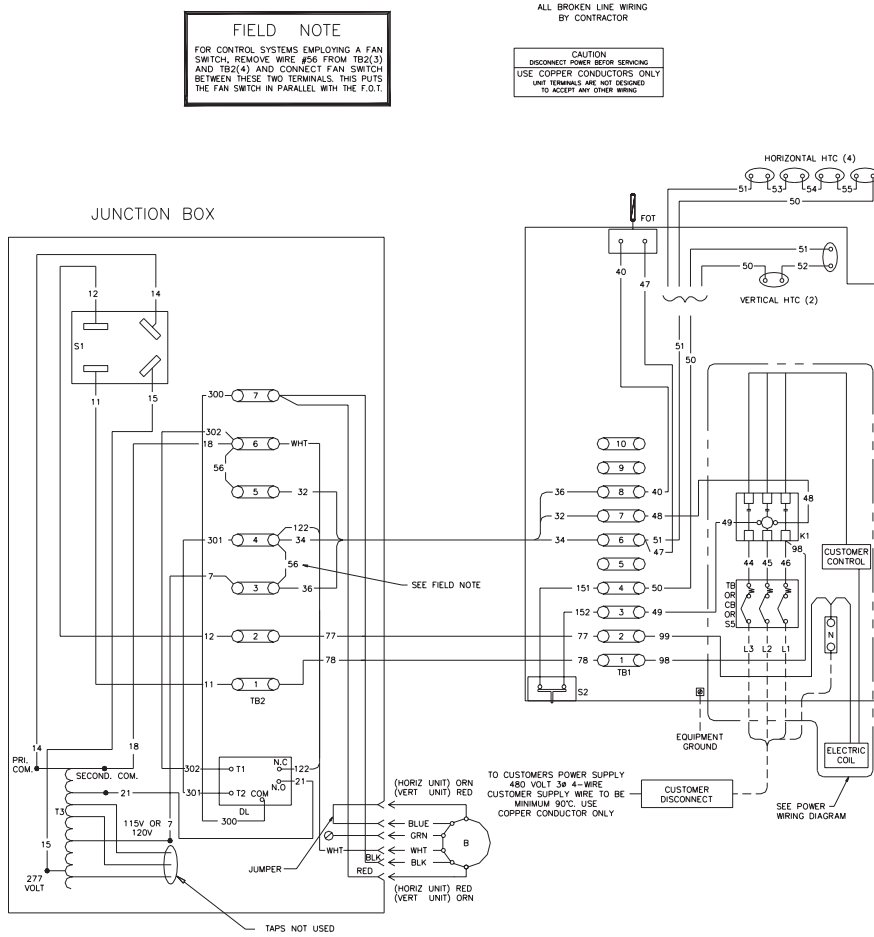

ITEM	DESCRIPTION
○	TERMINAL BLOCK R.H. (TB1)
□	TERMINAL BLOCK L.H. (TB2)
B	BLOWER MOTOR
DL	TIME DELAY RELAY
T3	AUTO - TRANSFORMER
FOT	FAN OVERRIDE THERMOSTAT
HTC	HI-TEMP CUTOUT
K1	CONTACTOR
S1	UNIT SWITCH
S2	PANEL INTERLOCK
SNB	SNUBBER

**LINE DIAGRAM**

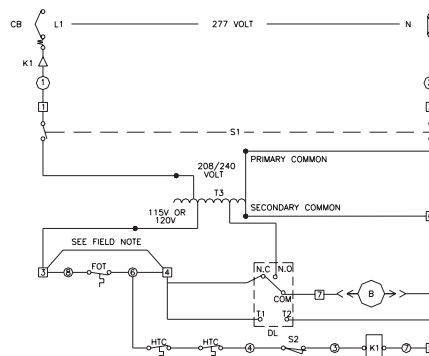

# Wiring Diagrams

**Figure 45:** End Device Package 120V, 4 Pipe Hot Water - Chilled Water

**NOTES:**

1. UNIT IS FIELD CONVERTIBLE TO A MEDIUM SPEED SETTING. TO ACCOMPLISH THIS, REMOVE HI SPEED WIRE FROM SWITCH TERMINAL NUMBER 4 AND REPLACE WITH WIRE MARKED "MED" IN CONTROL BOX.

2. ALL BROKEN LINES WIRED BY CONTRACTOR.

3. WHEN LLT IS NOT PRESENT OMIT WIRE #47 AND CONNECT WIRE #46 TO TB2-10.

<b>⚠ WARNING</b>	<b>⚠ AVERTISSEMENT</b>
HAZARDOUS VOLTAGE! DISCONNECT ALL ELECTRIC POWER INCLUDING REMOTE DISCONNECTS BEFORE SERVICING. FAILURE TO DISCONNECT POWER BEFORE SERVICING CAN CAUSE SEVERE PERSONAL INJURY OR DEATH.	VOLTAGE HASARDUEUX! DÉCONNECTEZ TOUTES LES SOURCES ÉLECTRIQUES INCLUANT LES DÉCONNECTEURS SÉPARÉS À DISTANCE AVANT D'EFFECTUER L'ENTRETIEN. FAUTE DE DÉCONNECTER LA SOURCE ÉLECTRIQUE AVANT D'INTERVENIR PEUT ENTRAÎNER DES BLESSURES CORPORELLES SÈVÈRES OU LA MORT.
<b>IMPORTANT</b>	
USE COPPER CONDUCTORS ONLY TO PREVENT EQUIPMENT DAMAGE. UNIT TERMINALS ARE NOT DESIGNED TO ACCEPT ANY OTHER WIRING.	

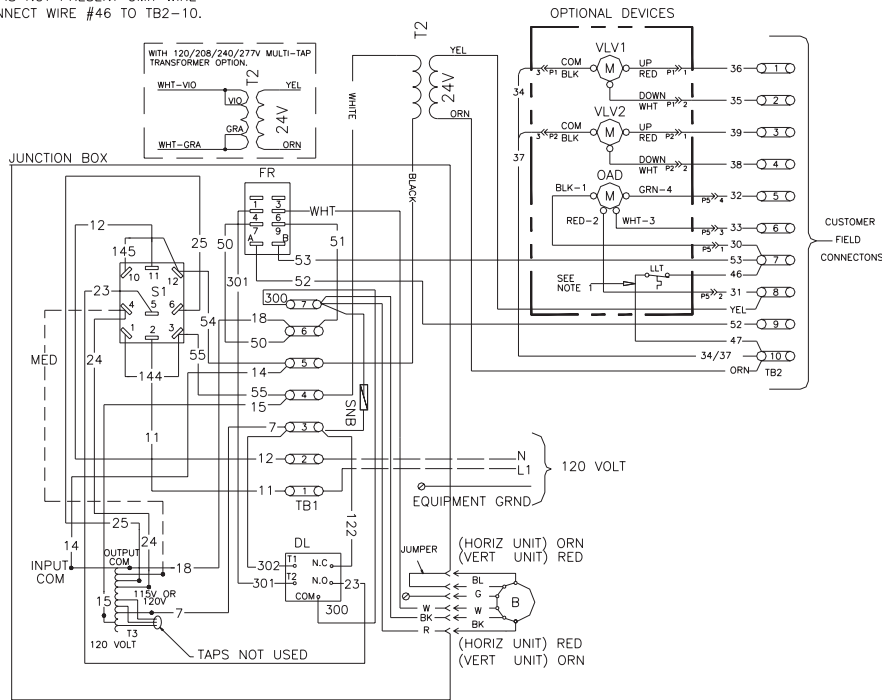

LINE DIAGRAM

ITEM	DESCRIPTION
□	TERMINAL BLOCK L.H. TB1
B	BLOWER MOTOR
DL	TIME DELAY RELAY
△	CONTROL TERM. BLOCK L.H. TB2
FR	FAN START STOP RELAY
OAD	OUTSIDE AIR DAMPER ACTUATOR
VLV	OPT. CONTROL VALVE
S1	UNIT SWITCH
T2	CONTROL POWER TRANSFORMER
T3	AUTO - TRANSFORMER
CBOP	CUSTOMER BINARY OUTPUT
CAOP	CUSTOMER ANALOG OUTPUT
LLT	LOW LIMIT THERMOSTAT
SNB	SNUBBER

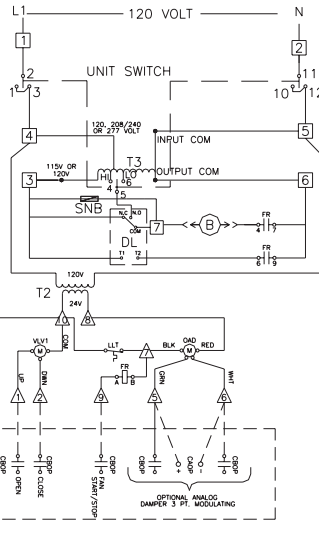

# Wiring Diagrams

**Figure 46:** End Device Package 120V, Hot Water - DX Cooling

<b>WARNING</b>	<b>AVERTISSEMENT</b>
HAZARDOUS VOLTAGE: DISCONNECT ALL ELECTRIC POWER INCLUDING REMOTE DISCONNECTS BEFORE SERVICING. FAILURE TO DISCONNECT POWER BEFORE SERVICING CAN CAUSE SEVERE PERSONAL INJURY OR DEATH.	VOLTAGE HAZARDEUX! DECONNECTEZ TOUTES LES SOURCES ELECTRIQUES INCLUANT LES DISCONNECTS REMOTE A DISTANCE AVANT D'EXECUTER L'ENTRETIEN. FAUTE DE DISCONNECTER LA SOURCE ELECTRIQUE AVANT D'EXECUTER L'ENTRETIEN PEUT ENTRAINER DES BLESSURES CORPORELLES SEVERES OU LA MORT.
<b>IMPORTANT</b>	
USE COPPER CONDUCTORS ONLY TO PREVENT EQUIPMENT DAMAGE. UNIT TERMINALS ARE NOT DESIGNED TO ACCEPT ANY OTHER WIRING.	

NOTE:

WHEN LLT IS NOT PRESENT  
OMIT WIRE #47 AND CONNECT  
WIRE #46 TO TB2-8.

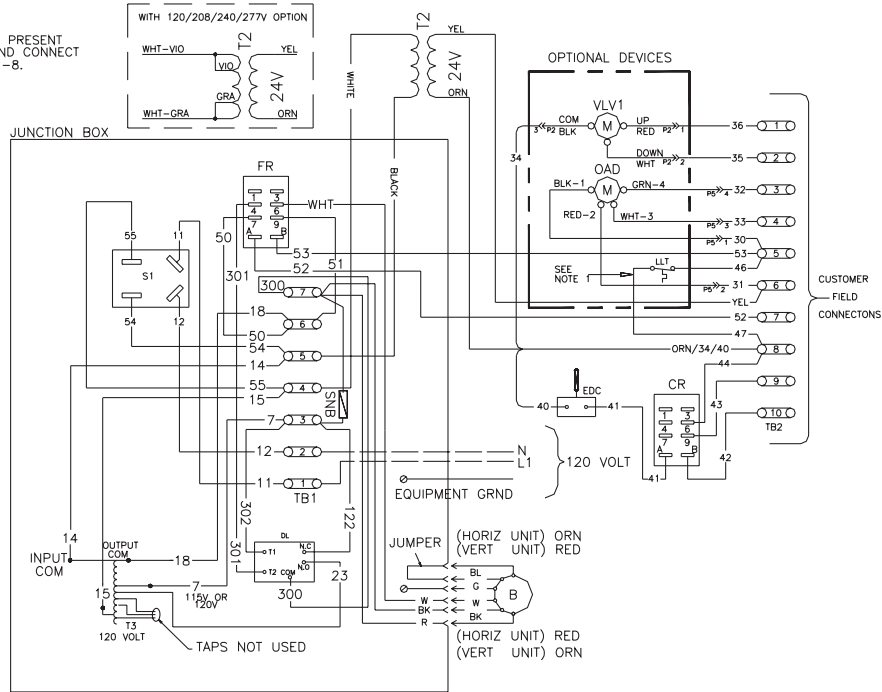

LINE DIAGRAM

ITEM	DESCRIPTION
□	TERMINAL BLOCK L.H. TB1
B	BLOWER MOTOR
DL	TIME DELAY RELAY
△	CONTROL TERM. BLOCK L.H. TB2
FR	FAN START STOP RELAY
OAD	OUTSIDE AIR DAMPER ACTUATOR
VLV	OPT. CONTROL VALVE
S1	UNIT SWITCH
T2	CONTROL POWER TRANSFORMER
T3	AUTO - TRANSFORMER
CBOP	CUSTOMER BINARY OUTPUT
CAOP	CUSTOMER ANALOG OUTPUT
LLT	LOW LIMIT THERMOSTAT
CR	COOLING RELAY
SNB	SNUBBER

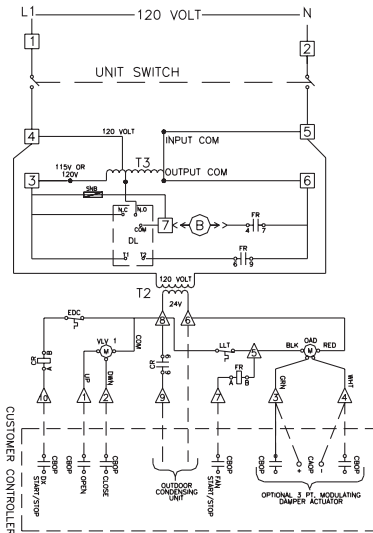

# Wiring Diagrams

**Figure 47:** 208V or 240V, 3-Phase, 3 Wire Electric Heat - DX Cooling

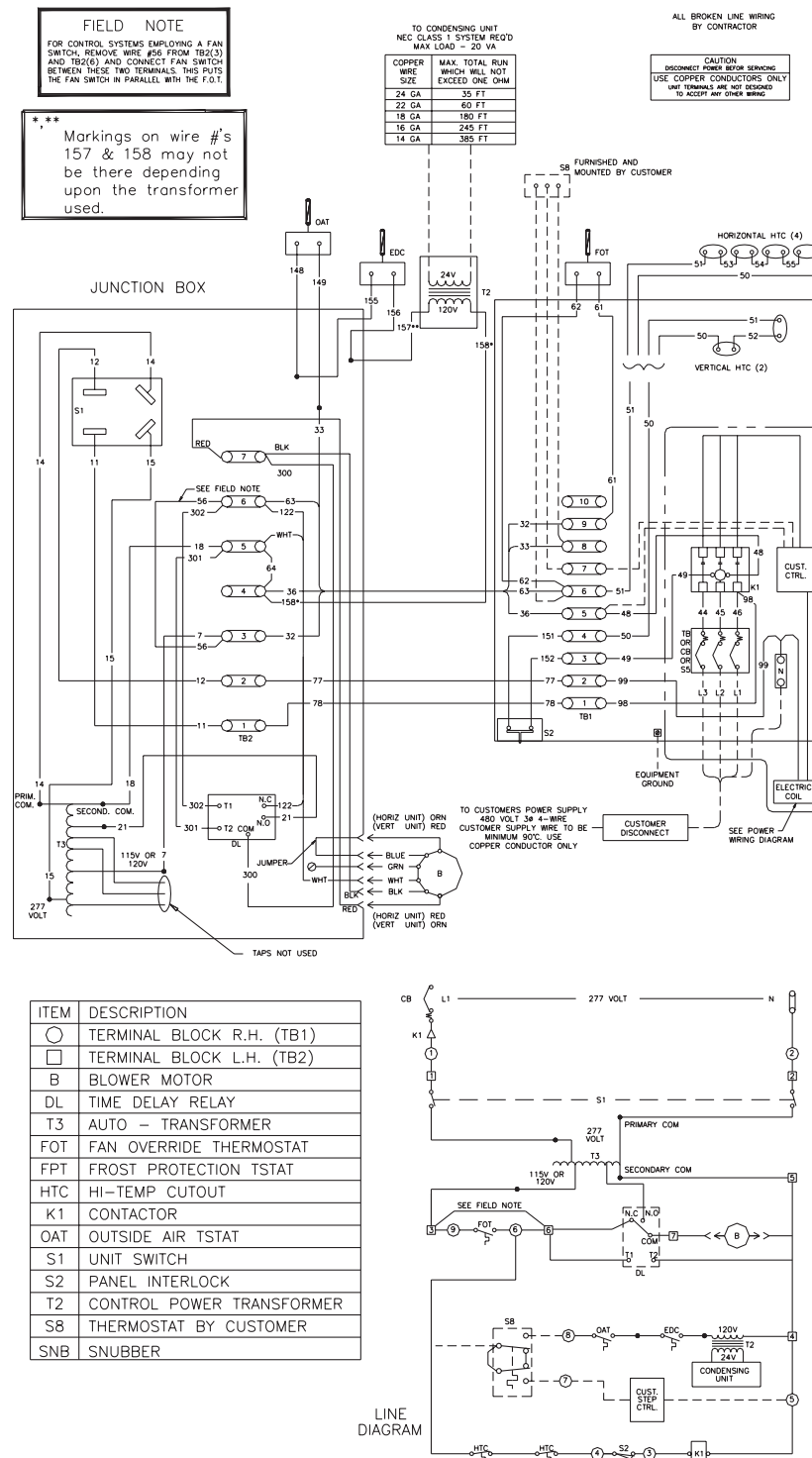



# Electrical Data

## Minimum Circuit Capacity

**Table 11** describes the typical MCA levels of a standard unit ventilator with the necessary voltage and amp add-ons for unit mounted controls.

**Table 11:** MCA levels for standard and hi-static motor unit ventilators

### Standard UV

Unit Size	HP	Amps
075	1/6 (.17)	2.5
100	1/6 (.17)	2.5
125	1/4 (.25)	2.7
150	1/4 (.25)	2.7
200	1/3 (.75)	5.7

### Hi-Static Motor UV

Unit Size	HP	Amps
075	1/3 (.33)	4.8
100	1/3 (.33)	4.8
125	1/2 (.50)	7.0
150	1/2 (.50)	7.0
200	3/4 (.75)	8.1

### UV with Controls

*For Trane Controls, add the following values to determine TOTAL MCA*

Volts	Amps
120	0.94
208	0.55
240	0.48
277	0.41
480	0.41

# Maintenance

## **⚠ WARNING** **Hazardous Service Procedures!**

The maintenance and troubleshooting procedures recommended in this section of the manual could result in exposure to electrical, mechanical or other potential safety hazards. Always refer to the safety warnings provided throughout this manual concerning these procedures. When possible, disconnect all electrical power including remote disconnects before servicing. Follow proper lockout/tagout procedures to ensure the power can not be inadvertently energized. When necessary to work with live electrical components, have a qualified licensed electrician or other individual who has been trained in handling live electrical components perform these tasks. Failure to follow all of the recommended safety warnings provided, could result in death or serious injury.

### **Service Access**

To access the unit for water balancing, motor access or other start-up and maintenance functions, use one of the following methods:

1. Remove the entire front panel and put a blockoff over the air chamber in

the front.

2. Remove the return air grille by releasing the mounting screws.
3. If there is no shelving or other obstructions, removing the end panel may allow more access..

### **Periodic Maintenance**

The following maintenance suggestions apply to all types of unit ventilators, chilled water, hot water, split systems and electric. Additional information for controls not supplied by The Trane Company should be obtained from the controls manufacturer.

Split system unit ventilators include a condensing unit and the instructions provided with the condensing unit will apply to the entire refrigerant system.

### **Filters**

The air filters supplied with Trane UV's are specially designed for high lint content. Depending upon room conditions, these filters will normally need to be replaced every 4 to 8 weeks. To assure proper unit operation, inspect the filters monthly and clean or replace as required.

Overloaded filters will reduce unit air handling capacity, which may result in insufficient heating during the morning warm-up period and loss of natural cooling capacity during mild weather.

### **Filter Replacement**

The air filter on the vertical unit is located near the bottom of the unit (Figures 48 & 49).

1. To remove the filter, begin by unscrewing the four screws holding the unit's return air grille in place.
2. Remove air grille and slide the filter out of the filter rack on the bottom of the unit.
3. Replace old filter with new one and re-attach return air grille

### **CAUTION**

#### **Equipment Damage**

*Do not operate unit without filters or grille in place. Failure to do so may cause equipment failure*

For horizontal units, lower the back access panel and lift the filter out of its channel and out of the unit.



**Figure 48:** For filter replacement, remove the screws holding the front air grille and remove the grille.



**Figure 49:** Slide out old filter and replace with new filter. Reattach return air grille.

# Maintenance

## Filters - continued

There are a number of filters available for use with the Trane Classroom Unit Ventilators. The following section explains maintenance and replacement of these filters.

Each filter is replaced in the manner previously discussed.

## Throwaway Filters

Throwaway filters contain adhesive coated glass fibers which are enclosed in a cardboard frame. Remove old filters from the unit and dispose of the entire filter. Replace with a new filter making sure the air flow direction arrows are pointing toward the discharge end of the unit.

## Permanent/Renewable Polyurethane Filters

Permanent/renewable filters consist of a polyurethane filter pad enclosed in a rigid frame. The frame is hinged at the back with dimple fastener at the front.

With the filter removed, open the frame, remove the pad and wash in a mild detergent solution. Allow the pad to dry and replace in the frame. Reinstall the filter. Over time, the filter

may wear out. Replacement pads may be ordered through Trane.

## Removal of the Drain Pan

The unit ventilators drain pan is removable for periodic cleaning or easy access for maintenance/drainage issues. Use the following **Figures 50-52**, and the below steps for removing the drain pan.

1. Turn off power to the unit and remove the front panel by turning camlocks .
2. Disconnect the condensate drain line.
3. Remove the support plates on each end by taking out the fastening screws.
4. Remove the 2 screws on the front face of the pan to release it.  
**NOTE:** *The drain pan is installed at an angle to allow drainage. For each end of the drain pan, remember the position (top or bottom slot) from which the fastener was removed.*
5. When reinstalling, use the same



**Figure 50:** Removal of screws in support plate of drain pan.



**Figure 51:** Removal of screws holding drain pan in place.



**Figure 52:** Slide drain pan out of unit for inspection/cleaning.

# Maintenance

steps in reverse order, remembering the pitch of the drain pan.

## Removal of the Fanboard & Coil Cleaning

The unit ventilator fan board can be removed for service to the blower motor and fan wheels. The fan board must also be removed for easier access to the unit coils for cleaning and maintenance. Utilize the following steps for proper removal of the fanboard.

1. Turn off power to the unit and remove the front panel.
2. Remove the front air grille and filter from the unit (As seen in **Figures 48-49**).
3. Unplug the fan motor from the controls package and remove crossover wiring from the clips on the fanboard. Some sensor wiring or tubes may also have to be removed

to allow fanboard removal. Take note of where these sensors are located and replace them when reinstalling the fanboard.

4. **For Units with Face & Bypass options only:** Before removing the fanboard, the drain pan must be removed (Figures 50-52). After the drain pan has been removed, proceed to Step 5.
5. Remove the 2 screws at the lower corners of the fan deck to release it. (**Figure 53**)
6. Slide the fan board forward to remove from the unit (**Figure 54**). **CAUTION:** *The fan board may need to be supported to prevent it from sliding forward and falling out of the unit.*
7. When reinstalling, use the same

steps in reverse order.

## Lubrication: Fan Shaft

One fan shaft bearing is mounted on the right end of the fan board. This sleeve-type bearing has an inner surface of sintered bronze which allows oil to flow from the built-in reservoir to the bearing surface without the use of grooves or holes in the inner bearing surface. Do not alter the inner bearing in any way.

Fill the bearing reservoir every six months with a No. 10 SAE, non-detergent, automotive type oil. Use a pressure oiler. Add oil until seepage is noted between the bearing and fan shaft.

## Lubrication: Motor Bearings

Motors are permanently lubricated and do not require any further oiling.



**Figure 53:** Loosen the four bolts (2 & 2) at either end of the fan board to begin board removal.



**Figure 54:** Slide fan board forward to remove.

# Maintenance

## Motor

The fan motor is a permanent split capacitor type motor with 115V power (Tables 7 and 8). If a replacement motor is required, it should be ordered from The Trane Company.

To replace the fan motor, complete the following steps:

1. Turn off power to the unit and remove the front cover.
2. Complete steps for return air grille and filter removal.
3. Complete steps for removal of drain pan if Face & Bypass option is installed.
4. Complete steps for removal of fan board.
5. Disconnect the motor ground wire
6. Using a 7/16" Allen wrench, loosen the coupling on the fan shaft.
7. Loosen the screw on the motor clamp until it allow the motor to be lifted off the base. (**Figure 56**)
8. Lift the motor and pull forward until fan shaft separates from the motor. (**Figure 57**).
9. Attach new motor to fan shaft and reverse steps to complete installation.

## Modulating Valves

The valve should be serviced by a trained, experienced technician. For detailed installation and removal steps, refer to Pages 28 & 29 in this manual). For general servicing or malfunction, follow one of the appropriate steps:

1. If the valve is leaking, drain system OR isolate valve from the system. DO

NOT remove valve body from plumbing.

2. Check to see if the cartridge needs to be replaced. If so, follow appropriate steps explained for cartridge assembly removal.
3. If the motor or other internal parts of the actuator is damaged, replace the entire actuator assembly.  
**NOTE:** *These hydronic valves are designed and tested for silent operation. However, water noise may occur as a result of high water velocity. Piping noises may also occur in high temperature (over 212 F) systems with insufficient water pressure.*

**NOTE:** *Do not use petroleum-based or mineral oil type boiler additives. Compounds with a 50% water dilution that can be used are diethylene glycol, ethylene glycol and propylene glycol.*

## Preventive Maintenance

A comprehensive preventive maintenance program should be established

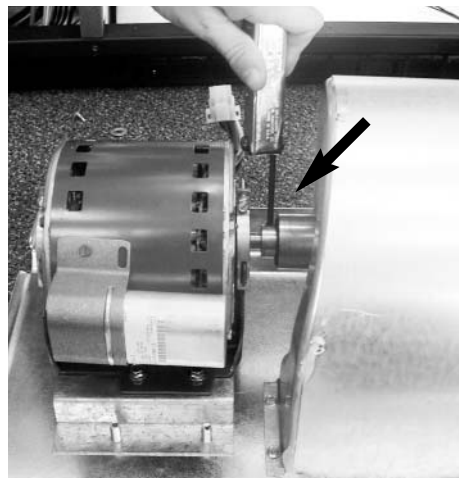
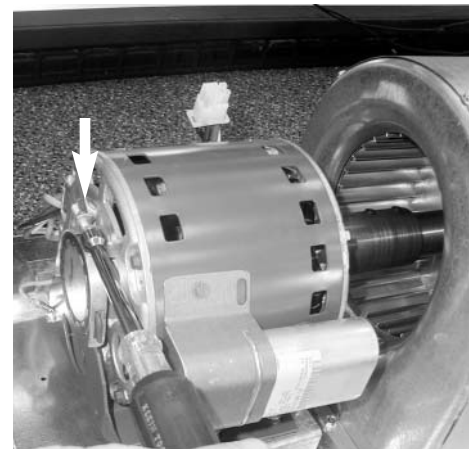

**Figure 55:** Loosening coupling on the fan shaft.

**Figure 57:** Remove the fan motor by lifting up and pulling forward.

for a unit ventilator system. The following are several key elements:

- Inspect the filters monthly. .
- Inspect and clean the drain pans every three months.
- Check the coils for "dirt" accumulation every three to six months.
- Clean the coils at least once each year.
- Inspect the unit ventilator insulation every three months; thoroughly clean as needed.



**Figure 56:** Loosening the clamp of fan motor.



# Troubleshooting

## Trouble Shooting Analysis

### **WARNING:**

#### **Hazardous Service Procedures!**

*The maintenance and troubleshooting procedures recommended in this section of the manual could result in exposure to electrical, mechanical or other potential safety hazards. Always refer to the safety warnings provided throughout this manual concerning these procedures. When possible, disconnect all electrical power including remote disconnects before servicing. Follow proper lockout/tagout procedures to ensure the power can not be inadvertently energized. When necessary to work with live electrical components, have a qualified licensed electrician or other individual who has been trained in handling live electrical components perform these tasks. Failure to follow all of the recommended safety warnings provided, could result in death or serious injury.*

If operating difficulties are encountered, refer to the following for probable causes and corrective measures. If suggested corrective measures have been taken, and the trouble still persists, contact the control supplier or the local Trane Sales Office.

### **Heating**

#### **A. Room Too Warm** --- Outside Temperature Below 35 F.

1. Check the room thermostat to make sure it is properly set.
2. If this occurs during the early part of the day, it may be due to the room thermostat giving a false reading caused by room walls still being cold from the night temperature setting. To correct, start the warm-up cycle earlier in the morning to give the wall a chance to come up to room temperature before the

room is occupied.

3. If the thermostat is mounted on a cinder block wall, the hole in the cinder block could cause cool air through the hole to affect the thermostat. In this case, the thermostat may need to be relocated.
4. Check for proper operation of the face and bypass damper or coil control valve. If the damper or valve appears to be functioning improperly, contact the control contractor or, if Trane controls, see **CNT-SVX04A-EN** (Tracer™ ZN520 Unit Controller IOP) for details on DDC controls.

#### **B. Room Too Warm** --- Outside Temperature Above 35 F.

1. Check the room thermostat to make sure it is properly set.
2. Check for proper operation of the face and bypass damper or coil control valve. If the damper or valve appears to be functioning improperly, contact the control contractor or, if Trane controls, see **CNT-SVX04A-EN** (Tracer™ ZN520 Unit Controller IOP) for DDC controls details.
3. Check the outside air damper. The outside air damper should be in the open position.
4. Check for a clogged filter. If the filter is clogged, the restriction of air flow may seriously reduce the ventilation capacity of the unit. Clean or replace the filter.
5. *If the installation utilizes Wall-Fin auxiliary radiation:*
  - a. *Hot Water* --- if control of water flow is provided, check the control valve for proper functioning.
  - b. *Boiler* --- Check the boiler reset schedule to determine if the loop temperature can be decreased.

c. *Steam* --- Check the operation of the control valves.

6. *Check the outside air temperature* --- is it above 60-65 F? The economics of the Unit Ventilator selection dictate that, in most cases, the unit will be sized to provide adequate natural (ventilation) cooling with outside temperatures up to 60-65 F. Above this point, a changeover should be made to the mechanical cooling cycle.

#### **C. Room Too Cool**

1. Check the room thermostat to make sure it is properly set.
2. Check the air filter. If clogged, renew or replace.
3. Check for proper operation of the face and bypass damper or coil control valve. If the damper or valve appears to be functioning improperly, contact the control contractor or, if Trane controls, see **CNT-SVX04A-EN** (Tracer™ ZN520 Unit Controller IOP) for details on DDC controls.
4. Check the outside air damper. It should be closed or at a minimum outside air setting.
5. On the hot water or steam type units, check the boiler pressure or temperature to make sure that design requirements are being met.
6. *If the installation utilizes Wall-Fin auxiliary radiation:* Check the radiation controls for proper operation.



# Troubleshooting

---

## Cooling

### A. Room Too Hot

1. Check the room thermostat to make sure it is properly set and that the thermostat is in the cooling cycle.
2. Check the outside air damper. The damper should be at a minimum outside air position.
3. Check for a clogged filter. This will reduce air flow and unit cooling capacity. If a clogged filter is found, clean or replace it.
4. *For chilled water cooling:*
  - a. Check for proper operation of the face and bypass damper or coil control valve. If the damper or valve appears to be functioning improperly, contact the control contractor or, if Trane controls, see **CNT-SVX04A-EN** (Tracer™ ZN520 Unit Controller IOP) for details on DDC controls.
  - b. Check the temperature of the water leaving the chiller to insure that it meets design requirements.

## Motor

If the motor fails to start and other motors on the same circuit are functioning:

- A. Check the unit switch to make sure it is in the "ON" position.
- B. Check for loose switch or motor connections.

Have a qualified electrician check the motor anytime it is operating improperly.

# Accessories - Wall Boxes

## General Information

The following instructions are general recommendations for installing wall intake boxes. Consult the architectural plans for specific requirements.

Additional materials required to complete any specific installations (such as duct connections, metal mounting plates, or flanges) *are not furnished* by Trane.

For best results, all air intake boxes should be removable from outside of the building. Weep holes must be at the bottom to permit free drainage. A positive air and moisture seal should be provided around all edges.

## General Instructions

Trane wallboxes are illustrated in **Figures 58 & 59** and each lists the wall openings required for wallboxes.

Vertical louvers in the wall intake box provide extra strength for a high load bearing capacity. The lintel may be omitted on masonry wall installations.

Weep holes are provided in the outside face of the bottom channel in the wall-box frame. Install all wall boxes to permit free drainage through the weep holes to the outside of the building.

All wallboxes are furnished with diamond pattern expanded aluminum bird screen.

**Note:** H1 (horizontal), V1 and V2 (vertical) wall models are all unflanged. H2, V3 and V6 are flanged.

**Figure 58:** Horizontal wallbox (H1 & H2) dimensions

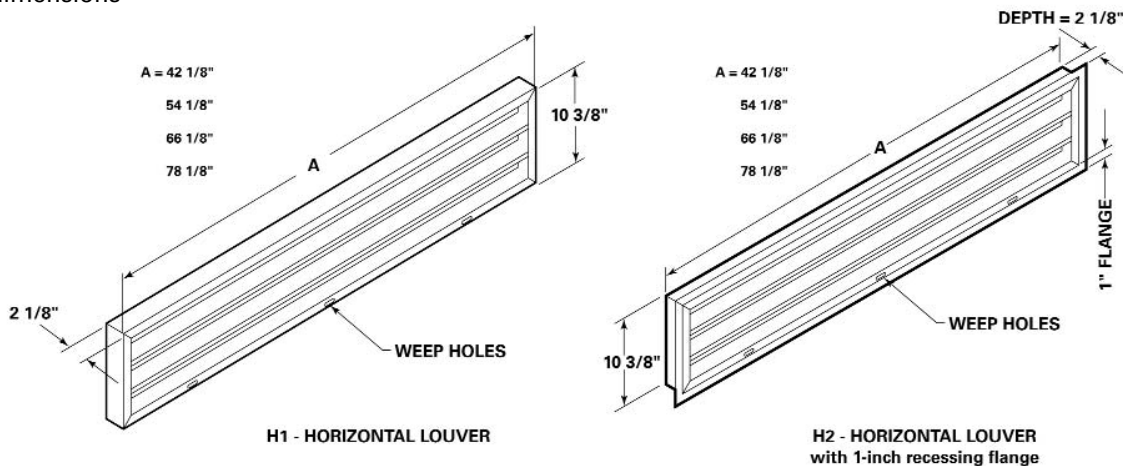

Unit Size	A	Square Feet of Free Area
075	42 1/8"	.81
100	54 1/8"	1.10
125	66 1/8"	1.39
150/200	78 1/8"	1.69

**NOTE:**  
THE DIMENSIONS LISTED ABOVE ARE ACTUAL (NOT NOMINAL) DIMENSIONS.

THE HORIZONTAL BLADES OF THE H1 AND H2 WALL BOXES ARE SPACED 2" APART.

# Accessories - Wall Boxes

**Figure 59:** Vertical wallbox (V1, V3, V2 & V6) dimensions

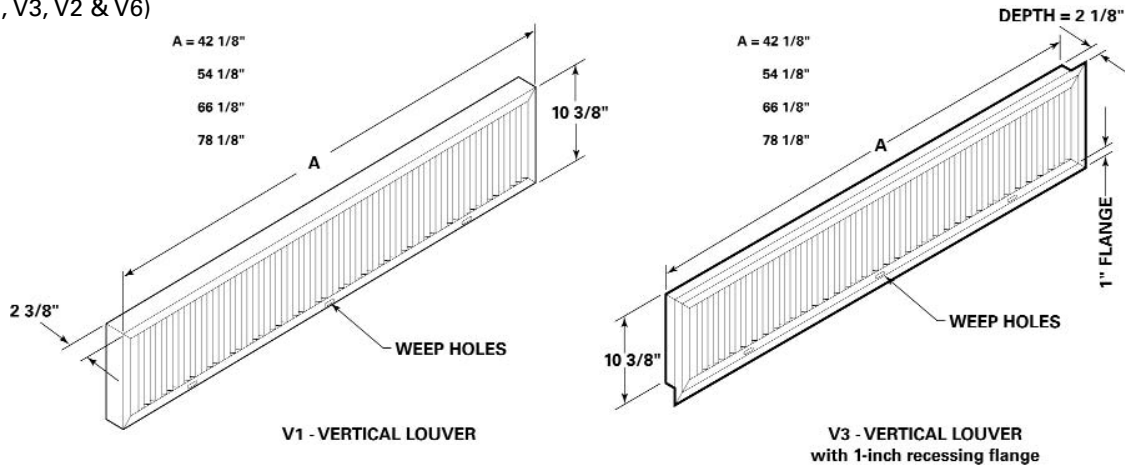

Unit Size	A	Square Feet of Free Area
075	42 1/8"	1.39
100	54 1/8"	1.88
125	66 1/8"	2.37
150/200	78 1/8"	2.87

**NOTE:**  
THE DIMENSIONS LISTED ABOVE ARE ACTUAL (NOT NOMINAL) DIMENSIONS.  
THE VERTICAL BLADES OF THE V1 AND V3 WALL BOXES ARE SPACED 3/8" APART.

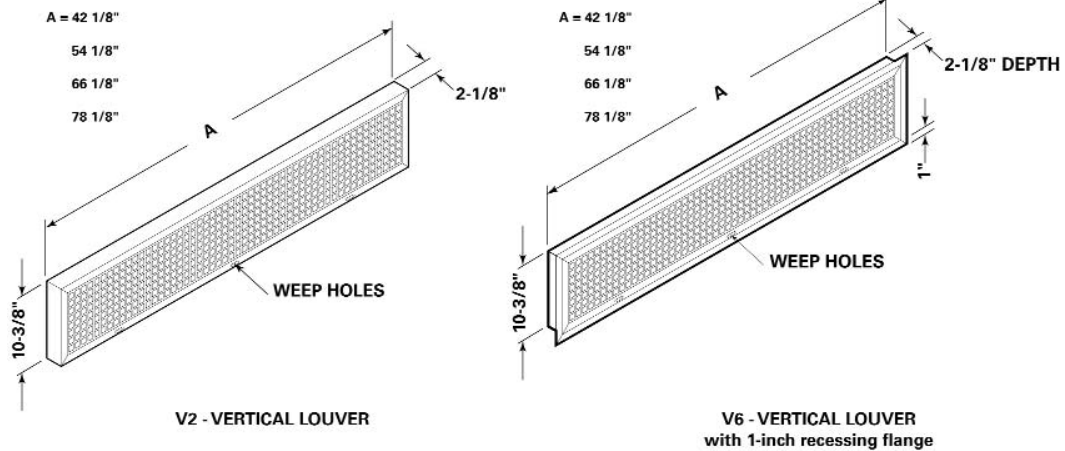

Unit Size	A	Square Feet of Free Area
075	42 1/8"	1.035
100	54 1/8"	1.345
125	66 1/8"	1.681
150/200	78 1/8"	1.992

**NOTE:**  
THE DIMENSIONS LISTED ABOVE ARE ACTUAL (NOT NOMINAL) DIMENSIONS.  
THE VERTICAL BLADES OF THE V2 AND V6 WALL BOXES ARE SPACED 3/8" APART.

# Accessories - Wall Boxes

## Installation in Masonry Walls

A typical method of installing the wall box in a masonry wall opening is illustrated in **Figure 60**.

Grout the top and bottom of the wall box frame as noted. A sloped water dam located in the space between the unit and wall facilitates moisture drainage. Grouting at the ends of the intake box will complete the seal between the wall box frame and the masonry opening.

## Installation in Curtain Walls

In all cases, the wall intake box should be caulked to provide a tight, weather-proof seal. See **Figure 61**.

Note: A minimum of 2-1/8" of clearance must be maintained between the exterior wall and back of the unit. Failure to provide this gap will not allow the wall box to fit properly.

**Figure 60:** Wallbox installation in masonry wall

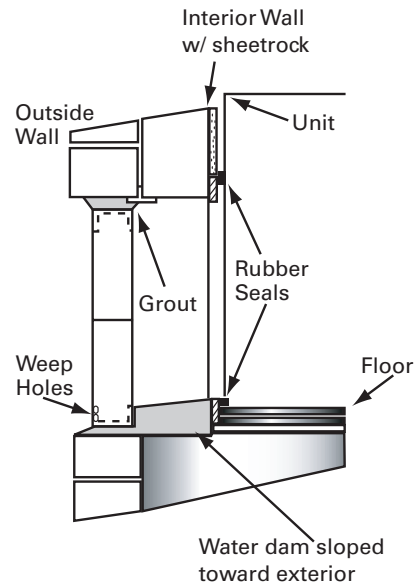

**Figure 61:** Flanged wallbox installation - 2" wall.

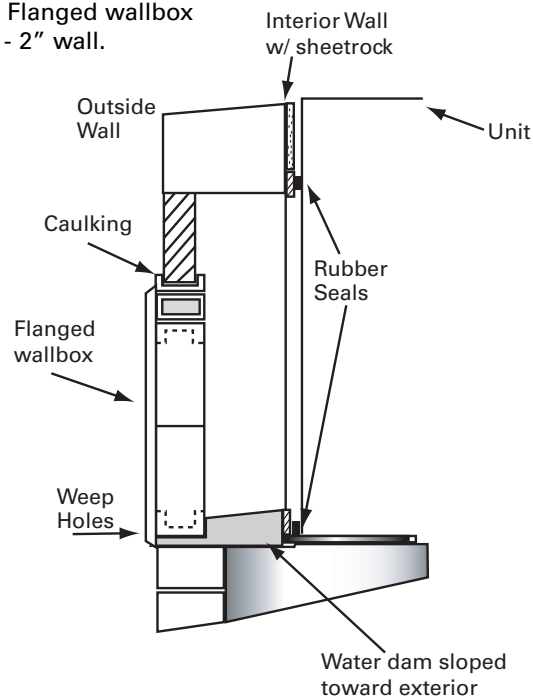



# Other Accessories/ Related Literature

---

There are a number of accessories and optional add-ons that can be ordered with the Classroom Unit Ventilator, including:

- Energy Recovery Units (ERSA)
- Classroom Unit Ventilator Shelving components
- Side-Wall Exhaust units
- Tracer ZN520 DDC unit controllers.

Each of these accessories is supported by its own Installation, Diagnostics or Programming manuals. Please refer to the following Literature Reference list for related literature that may be needed to complete your installation:

## Related Installation Literature

- **UV-SVN001-EN:** *Classroom Shelving Model SHL IOD*
- **ERS-IOM-1:** *Vertical Floor Energy Recovery Unit IOM*
- **SWE-IOM-1:** *Vertical Floor Side Wall Exhaust IOM*
- **CNT-SVX04A-EN:** *Tracer ZN520 Unit Controller IOP*



Trane  
A business of American Standard Companies  
[www.trane.com](http://www.trane.com)

For more information, contact  
your local district office or  
e-mail us at [comfort@trane.com](mailto:comfort@trane.com)

---

Literature Order Number	SV-TD-UV-SVN02B-EN-02/05
Date	February 2005
Supercedes	SV-TD-UV-SVN002-EN-12/03
Stocking Location	Inland

---

Trane has a policy of continuous product and product data improvement and reserves the right to change design and specifications without notice.