



TRANE®

Diagnostic Troubleshooting Repair

RTHD and RTAC

Control Operation, Setup and Troubleshooting for RTAC and RTHD Units with Tracer CH530 Controls

The purpose of this bulletin is to provide control operation and general troubleshooting information on the RTAC Air Cooled Chillers and RTHD Water Cooled Chillers with the CH530 controls. It is recommended that the service technician be familiar with the CH530 operation prior to servicing the microprocessor.

This bulletin is intended to serve as a supplement to the RTAC and RTHD IOMs, the installation, operation and maintenance manual. Subjects covered in this bulletin are intended to provide more comprehensive information for the RTAC and RTHD units.



Warnings and Cautions

Important - Read This First!

This manual is intended for experienced service personnel familiar with the proper use of electrical diagnostic instruments and all personal safety procedures when working on live electrical circuits.

This Manual is not intended for individuals who have not been properly trained in handling live electrical circuits.

NOTICE: Warnings and Cautions appear at appropriate sections throughout this literature. Read these carefully.

⚠ WARNING: Indicates a potentially hazardous situation which, if not avoided, could result in death or serious injury.

⚠ CAUTION: Indicates a potentially hazardous situation which, if not avoided, may result in minor or moderate injury. It may also be used to alert against unsafe practices.

CAUTION: Indicates a situation that may result in equipment or property-damage only accidents.

Important Environmental Concerns!

Scientific research has shown that certain man-made chemicals can affect the earth's naturally occurring stratospheric ozone layer when released to the atmosphere. In particular, several of the identified chemicals that may affect the ozone layer are refrigerants that contain Chlorine, Fluorine and Carbon (CFCs) and those containing Hydrogen, Chlorine, Fluorine and Carbon (HCFCs). Not all refrigerants containing these compounds have the same potential impact to the environment. Trane advocates the responsible handling of all refrigerants—including industry replacements for CFCs such as HCFCs and HFCs.

Responsible Refrigerant Practices!

Trane believes that responsible refrigerant practices are important to the environment, our customers, and the air conditioning industry. All technicians who handle refrigerants must be certified. The Federal Clean Air Act (Section 608) sets forth the requirements for handling, reclaiming, recovering and recycling of certain refrigerants and the equipment that is used in these service procedures. In addition, some states or municipalities may have additional requirements that must also be adhered to for responsible management of refrigerants. Know the applicable laws and follow them.

⚠ WARNING Contains Refrigerant!

System contains oil and refrigerant under high pressure. Recover refrigerant to relieve pressure before opening the system. See unit nameplate for refrigerant type. Do not use non-approved refrigerants, refrigerant substitutes, or refrigerant additives.

Failure to follow proper procedures or the use of non-approved refrigerants, refrigerant substitutes, or refrigerant additives could result in death or serious injury or equipment damage.



Contents

CH530 Overview	5
Main Processor	5
Starter Module	5
Power Supply Module	5
LLIDs (Low Level Intelligent Devices)	5
IPC Overview and Troubleshooting	7
Installing a LLID	8
Bus connection crimping procedure	8
Procedure for installing caps.	10
Troubleshooting problems with multiple LLIDS	11
Power Supply	14
Troubleshooting	14
Temperature Sensor	16
Sensor Checkout Procedure	16
Is the sensor bound and communicating?	16
Is the sensor reading accurately?	17
Pressure Transducers	18
Transducer Checkout Procedure	18
Is the transducer bound and communicating?	18
Is the transducer reading accurately?	19
Variable Speed Fan Control - RTAC Only	20
Startup and Operation	20
Inverter Fault Input	22
Troubleshooting the Inverter	22
Current Transformers	26
CT and Starter Compressor Current Input Checkout Procedure	27
Over/Under Voltage	30
RTAC Chillers	30
Check out procedure for RTAC	30
Under/Over Voltage Transformer Checkout	30
RTHD Chillers	31
Check out procedure for RTHD	31
Potential Transformer	31
Starter Module	33
Starter	34
X-Line	34
Y-Delta	34
YDelta Starter Sequence	36
Solid State - RTHD Only	43
Compressor Capacity - RTHD	44
Checkout Procedure for the Load-Unload Outputs	44
Checkout procedure for the Slide Valve and Load-Unload Solenoids	45
Load	47
Unload	47
Compressor Capacity - RTAC	48
Checkout Procedure for the Female Step Load Outputs	49
Checkout Procedure for the Step Load Solenoids Valve and Piston	49
Checkout Procedure for the Male Load-Unload Outputs	49
Checkout procedure for the Slide Valve and Load-Unload Solenoids	50



Contents

Setup	50
Load	52
Unload.	52
Electronic Expansion Valve	54
EXV Checkout Procedure	54
Is the EXV bound and communicating?	54
Is the EXV functioning properly?	55
Liquid Level Sensor	57
External LLID Sensor	57
Internal LLID	57
Liquid Level Sensor Checkout Procedure	57
Is the sensor bound and communicating?	57
Is the sensor reading accurately?	58
Gas Pump - RTHD Only	59
Gas Pump Checkout Procedure - Unit Off	59
Gas Pump Checkout Procedure - Unit On	60
Optical Sensor - RTHD Only	61
Checkout Procedure	61
TechView Service Tool	62
Software Requirements	62
Hardware Requirements	62
Laptop requirements for CH530	63
The Download Process	63
Instructions for First Time Tracer™ CH530 Users	63
Using TechView	65
Downloading New Main Processor Software	67
Binding Process	67
Binding Symbols	70
Modify Chiller Configuration	70



CH530 Overview

CH530 is a distributed architecture control that puts communication capability and some limited intelligence down at the sensor level (Low Level Intelligent Devices, or LLIDs). Higher level modules or Super LLIDs (starter) exist only as necessary to support system level control and communications where subsystems require a collection of I/O and intelligence.

The primary benefit of the LLIDs architecture is the low cost of replacement parts. CH530 architecture allows a single point to be replaced with only pig-tail wiring and electronics dedicated to a particular point.

Main Processor

The main processor is the “master of the chiller” by collecting data, status, and diagnostic information and communicating commands to the other modules (starter) and the LLID bus. The communications bus is called the Inter-Processor Communications. The main processor is located in the human interfaces (DynaView, EZView).

Starter Module

The starter module provides control of the compressor contactors when starting, running, and stopping the chiller. Starter types include Across the Line (RTAC), Y-Delta and Solid State (RTHD). The starter module provides protection of the compressor in the form of running overload, phase reversal, phase loss, phase imbalance, and momentary power loss.

Power Supply Module

The power supply module provides 24VDC power to support all of the module and LLIDs functions.

LLIDs (Low Level Intelligent Devices)

The following devices are types of inputs and outputs that exist as LLIDs. Some of the LLIDs are optional. The number and type of LLIDs are dependent on the unit size and configuration.

- temperature sensors
- low voltage binary inputs
- high voltage binary inputs
- analog input/output
- relay output
- triac output

- EXV stepper driver
- liquid level sensor input
- inverter interface
- pressure transducer

The following is a graphic example of the CH530 architecture.

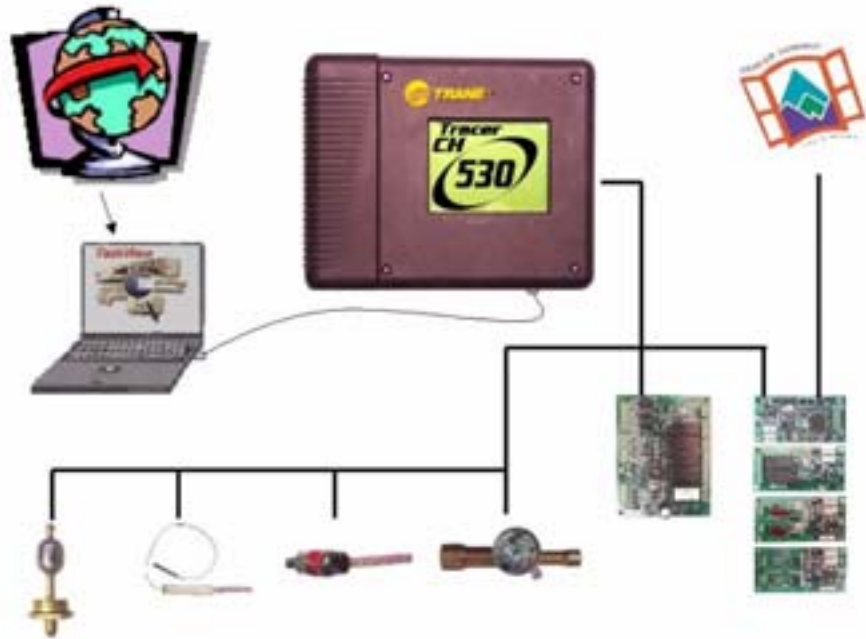


Figure 1. CH530



IPC Overview and Troubleshooting

The CH530 platform provides a highly modular approach for accommodating the inputs and outputs to control a chiller. The CH530 platform includes discrete devices for each input and output point on the system. For example, the EXV includes the electronics to drive its motor contained within the motor housing. The liquid level sensor includes the electronics necessary to read the float level. Each temperature sensor includes the electronics to measure the thermistor value.

The CH530 platform is very generic to various chiller sizes or model applications. A four compressor design does not require a different module design than a two compressor design, nor did the two compressor design take on un-used components.

An additional benefit to the LLID (low level intelligent device) approach is that parts stocking is greatly simplified. LLIDs of each type are not dedicated to a particular chiller design but can be applied individually across all sizes or models.

In the typical installation, there are two sets of devices. One set of devices is installed in a control panel. This first set includes power supplies, devices that require customer wiring, and the main processor. Devices in the second set are installed at points of use around the unit and wired by stubs to a main trunk (IPC bus).

The DynaView or EzView provides the user interface and the system main processor. The main processor is the master of the chiller by collecting data, status, and diagnostic information and communicating commands to the other modules (starter, purge) and the LLID bus. The main processor also serves as the bus manager. Functions of the bus manager include timing out communication failures and recovering from errors on the IPC network.

Out of the box, all EzViews, and DynaViews are generic in that no software (application code or chiller configuration) is installed until programmed by TechView. In the same way that LLIDs are generic until applied, so is the main processor. A service parts desk or technician can stock a main processor and give it an identity at the point in time it is applied to a chiller.

There is additional information that each device must be "bound" with that is dependent on its application. This additional data is called "binding information" and is written to each device either by the factory tester or the TechView Service Tool.

LLIDs must communicate with the main processor in order to be identified, recognized, and differentiated from a neighboring device, a service LED and switch are located on each LLID is used to identify a specific device. On CH530 a temperature sensor is bound by being assigned a node number. The binding

process requires a LLID to be recognized by activating its service pin or green LED.

All LLIDs are constructed with a green LED and associated switch. The switch is a hall-effect sensor, which is activated by a magnetic field of the proper polarity (South Pole). The LED should seem to be brighter when the magnet is in proximity with the hall effect service switch and should stay on, but appear dimmer when the magnet is removed. The LLID is said to be "selected" in this state

The LLID software is designed to light the LED on reset and turn it off after passing memory tests. If the LED turns on and remains lit after power-up, a failure of the LED circuit or a bad memory test could be the cause. It is normal to notice a short flash of the LED after a reset. The absence of a flash could indicate a failure of the LED circuit or that the device is not programmed.

The LED circuit is designed to light the LED while the switch is active, so the LED can be used to detect that power is supplied. If the LED fails to light when a user attempts to activate the switch, either loss of power or a hardware problem is indicated.

The LED software is designed to enter a special state, to become "selected", when the LED switch is activated. When the LLID becomes selected as a result of the switch activation (by magnet), it automatically turns on the LED. Software lights the LED at 50% duty cycle when the state is on, and the user perceives a steady light that is only slightly dimmer than while the switch is activated. If the LED does not remain lit after the switch is activated, one potential cause is a software failure.

Installing a LLID

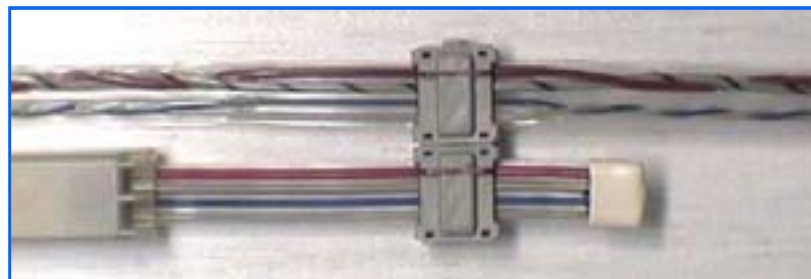


Figure 2. Installed LLID

Bus connection crimping procedure.

- 1 The connector must be installed on parallel portion of wire. Care must be taken to ensure no part of the connection is on a twisted portion of the wire.

- 2 Insert the cable into the connector. The cable edges must be hooked beneath the four cable retainer tabs. Push the cable into the connector to lock it beneath these tabs.

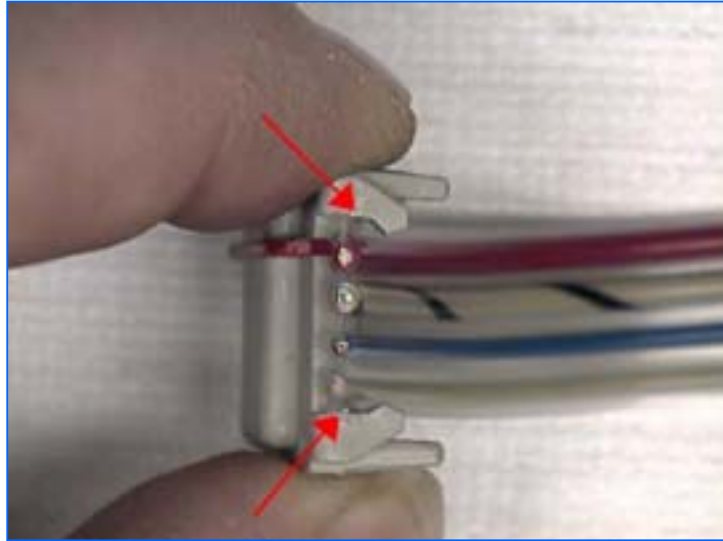


Figure 3. Cable and Connector

- 3 Place the cover and wire over the base and hold in place. Crimp the connector down using the Trane tool or a parallel jaw pliers

It is important to apply equal pressure across the jaws of the pliers.

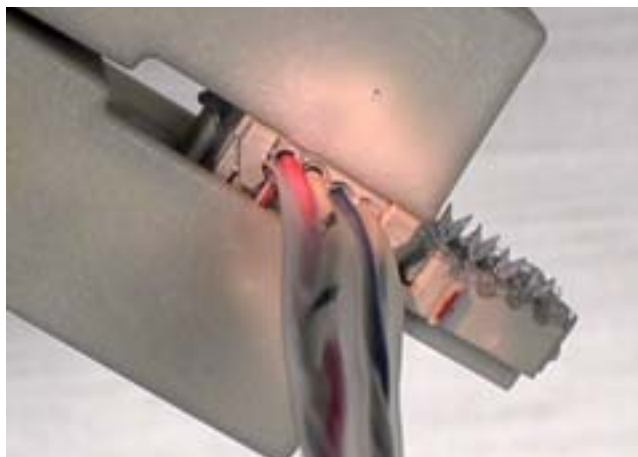


Figure 4. Pliers

- 4 Inspect finished connector. Make sure the red wire matches up with the red line on the connector. Verify that no wires are twisted in the connector.

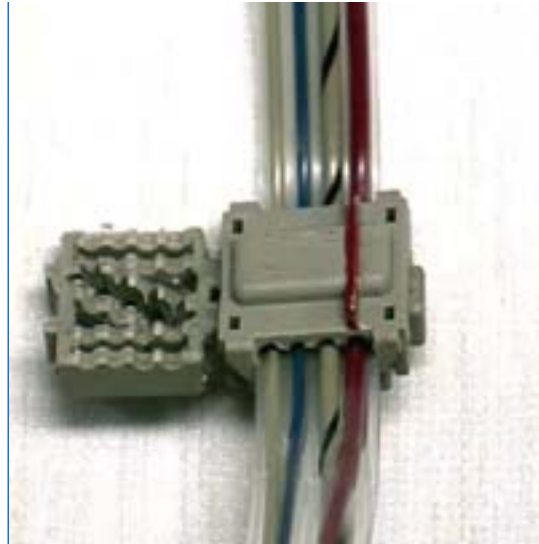


Figure 5. Finished Connector

Procedure for installing caps.

A cap must be installed on the bare end any time the is cut and/or spliced.

- 1 Always cut in parallel section of wire. If cuts are made on twisted wire, shorting of the wire pairs will occur. An angle cut is necessary for the proper installation of the protective cap. Refer to [Figure 6](#).



Right



Wrong

Figure 6. Wire

- 2 Place a small amount of Loctite 480 in the cap and put the end of the cable in the cap. Refer to [Figure 7](#).



Figure 7. : Cap

Troubleshooting problems with multiple LLIDS

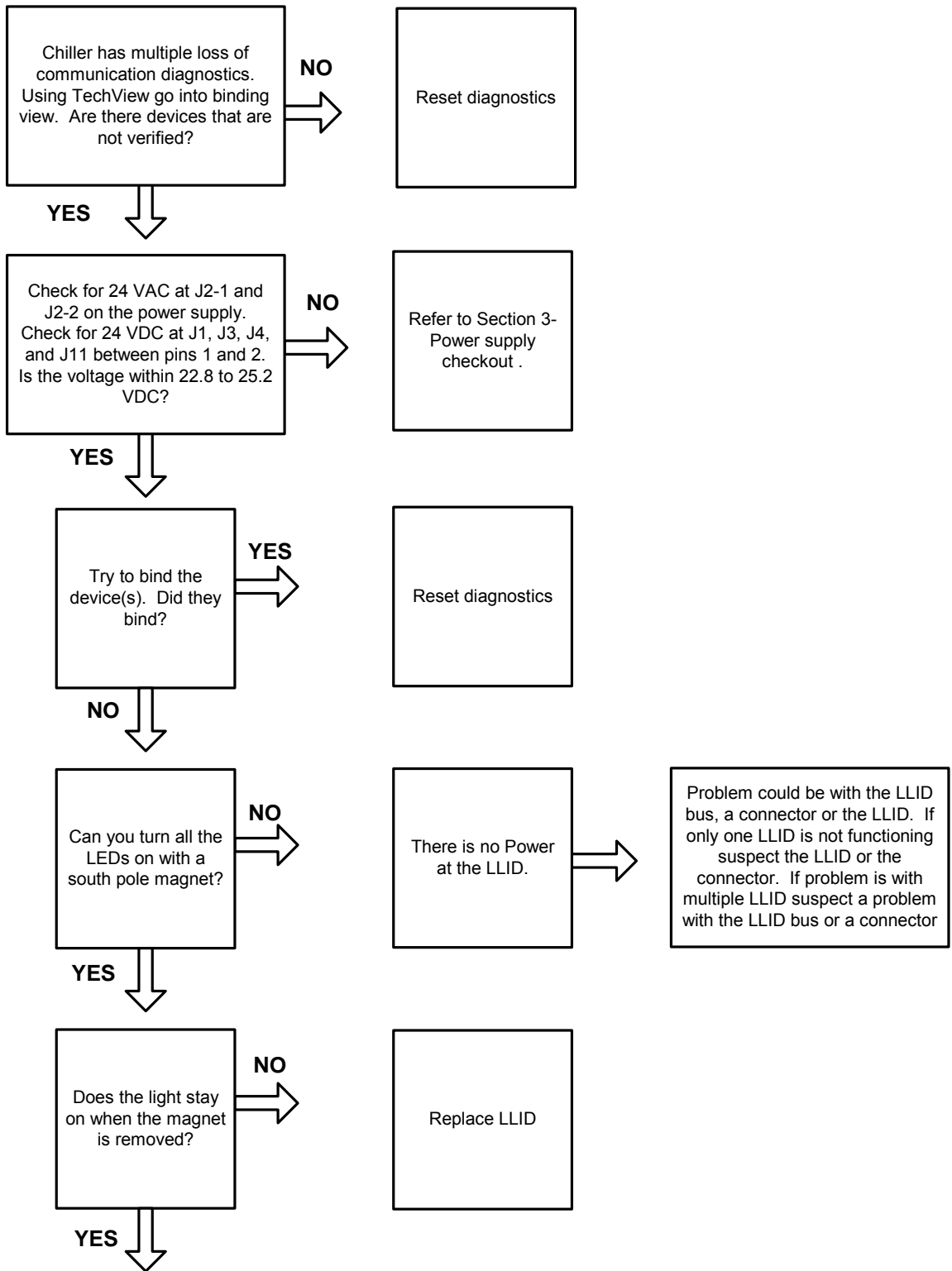
Troubleshooting bus communication problems can be challenging. It is important to remember that all of the LLIDs communicate on the same two wire communication bus, and derive their power from the same two wire power bus. Since the LLIDs are effectively in parallel with all other LLID, certain LLID failures or connector shorts can take down the entire bus, either the power bus, or the comm bus. In the case of shorts, the offending connector identified by the TechView Service Tool using Binding View. Most, if not all of the LLIDs will show up to be “unverified”. Most of these kinds of failures must be tracked down manually.

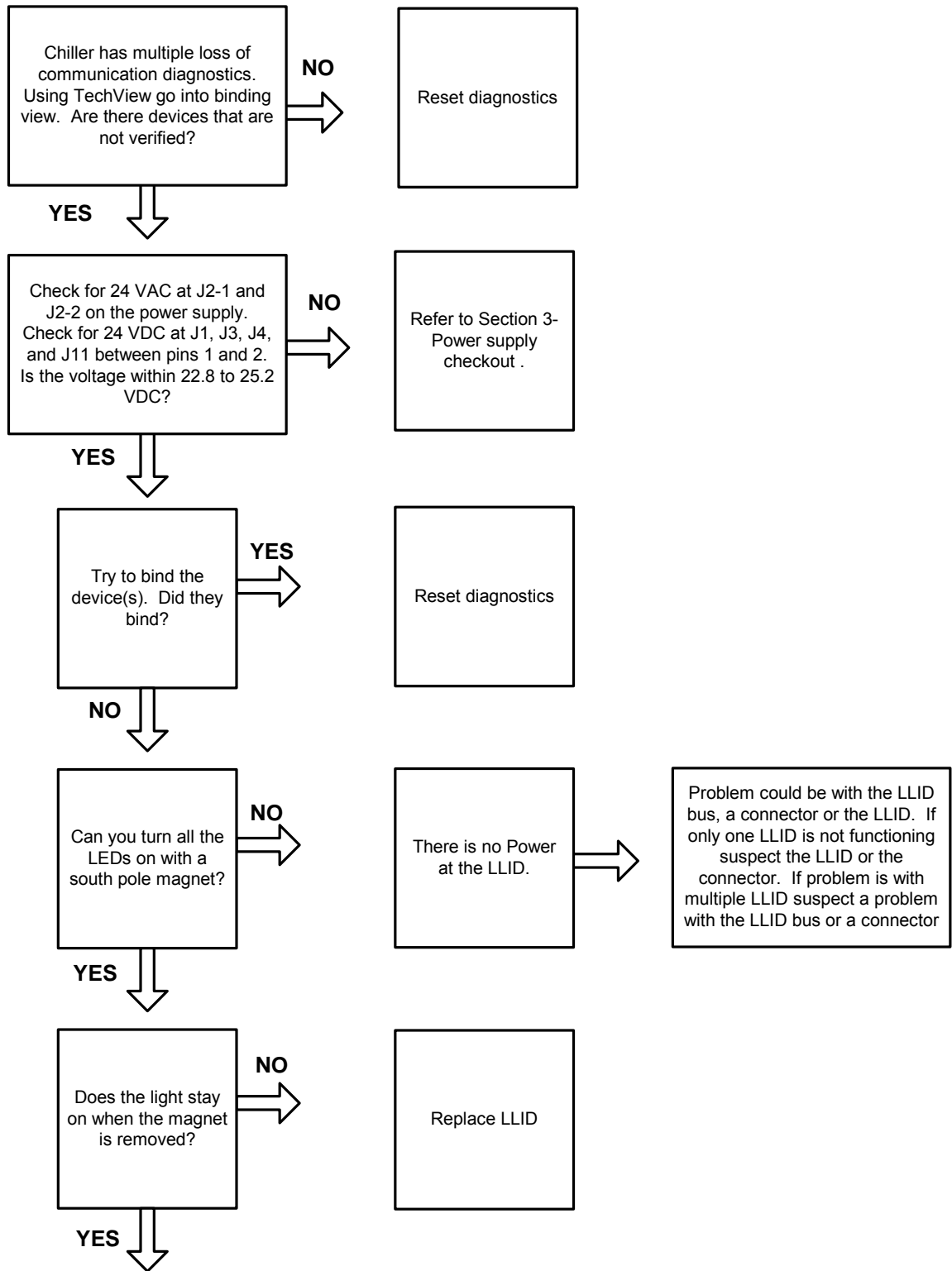
A problem will usually fall in one of four scenarios.

Connect TechView and go into binding view. One of the following scenarios should be present.

- All LLIDs verified (green smiling face(s)). Suspect a communication problem. It may be necessary to unbind and rebind some or all of the LLIDs.
- All LLIDs not verified (red frowning face(s)). Suspect a short or failed device.
- 1/2 of the LLIDs not verified (red frowning face(s)). If all LLIDs that are not verified are on the frame or in the control panel suspect a communication problem. If some of the LLIDs are on the frame and some are in the panel, then suspect a short or failed device.
- One or two of the LLIDs are not verified (red frowning face). Suspect LLID or connector problem.

Use the following flow chart to troubleshoot multiple LLID problems. For this procedure, a south pole magnet and TechView will be required.





Power Supply

The CH530 power supply has no communication capabilities. It provides 24VDC to the LLIDs and acts as the trunk for the IPC bus. It is also used as a “central hub” to provide a starting point for up to 5 IPC bus cables.



Figure 8. Power Supply

Troubleshooting

The input voltage on the power supply is 23 to 30 VAC and the output voltage is 22.8 to 25.2 VDC.

The input voltage should fall within the following values.

Table 1. Input Voltage

Terminations	Voltage	Min.	Max
J2-1	27 VAC	23 VAC	30 VAC
J2-2	27 VAC	23 VAC	30 VAC
J2-3	GRD		

Table 2 list the values for the output voltage on the power supply. If the green LED 1 is lit it implies that there is a good DC output voltage being produced by the board. Output for terminals J1, J3, J4, J5 and J11 are the same. The voltage output should be within $\pm 5\%$.



Power SupplyPower Supply

Table 2. Output Voltage

Terminals	Voltage
1	+24VDC
2	GND
3	COMM+
4	COMM-

There is a 3.0 amp fuse (X13110456020) on the power supply. If this fuse is open LED 1 will not be on and there will not be any voltage out. This fuse can be replaced. The fuse is a medium time delay 3.0 amp, 5X20mm.

Temperature Sensor

All of the temperature sensors used on CH530 are negative temperature coefficient (NTC) thermistors and located in thermal wells. The thermistors all have a base resistance of 10 kOhms at 77 F (25C). The sensors have a probe range of -40 to 120 F and should have an accuracy of $\pm 1F$.

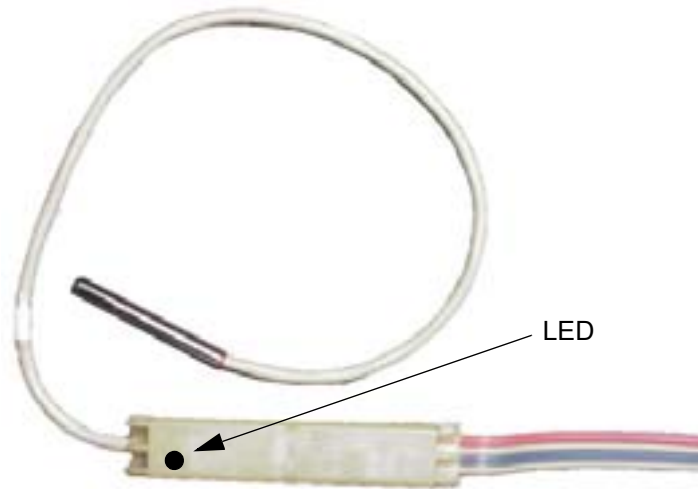


Figure 9 Temperature Sensor

Sensor Checkout Procedure

Is the sensor bound and communicating?

Connect TechView and get into Binding View. This will shut the chiller down. Once in Binding View, verify that the Temperature Sensor is bound.

Note: Please refer to Service Tool for questions concerning binding LLIDs and getting into Binding View.

If there are multiple LLIDs that are not verified go to IPC troubleshooting.

If the sensor is not bound, try to bind it. If the sensor will not bind it could be a problem with the connector or the sensor itself. Take a close look at the connector to make sure that all four wires are securely in place. It may be necessary to remove the cap to check for broken or misplaced wires.

CAUTION Equipment Damage Possible!

All units built before October 1, 2002 (U02#####) used connectors that must be replaced if the cap is removed. If the cap is removed on any of these units cut out the old connector and splice in a new section of cable and a new connector. See Section 2-IPC Overview for instruction on installing a new cap.

If the sensor is bound, try to turn the LED on with a magnet. If the light will not turn on there could be a problem with the sensor. Try to turn the light on in Binding View. With the light on hold the magnet to the LED. The LED should get



Temperature Sensor

brighter. If it doesn't get brighter, this may indicate a problem with the sensor or the connector. Take a close look at the connector to make sure that all four wires are securely in place. It may be necessary to remove the cap to check for broken or misplaced wires.

If there is no problem found with the connector and the sensor will not bind, replace the sensor.

Is the sensor reading accurately?

All temperature sensors on RTAC units are in thermal wells. Cycle the chiller off prior to testing the sensor.

- 1 Remove the sensor of concern from the well.
- 2 Place the sensor, while still connected to the LLID bus, in an ice bath.
- 3 Monitor the temperature on DynaView or TechView. The temperature should approach 32 F.
- 4 If the sensor is bound correctly but doesn't approach 32 ± 1 F, replace the sensor.

If the temperature does approach 32 F, then re-install the sensor in the well with suitable heat transfer paste.

Pressure Transducers

All of the Pressure Transducers used on RTAC and RTHD units are mounted on service valves. Pressure Transducers measure absolute pressure. They have a range of 0 to 475 psia with an accuracy of ± 1.5 psi under steady state conditions.

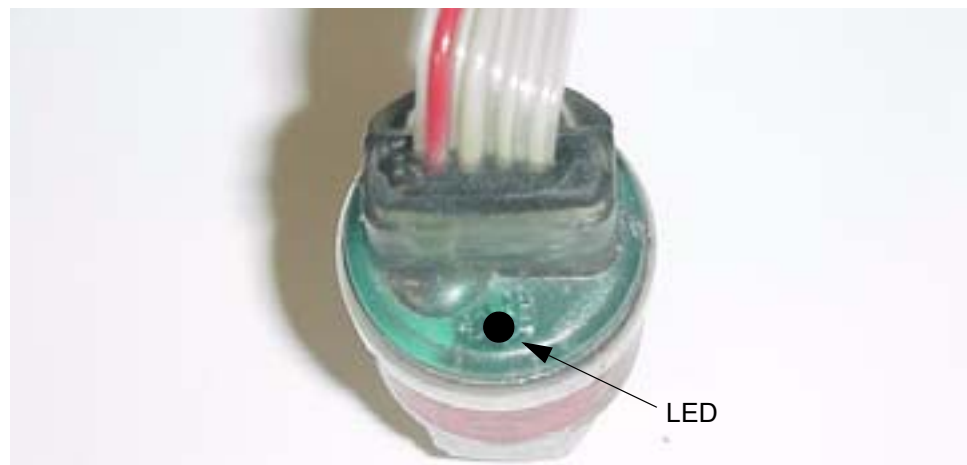


Figure 10. Pressure Transducer

Transducer Checkout Procedure

Is the transducer bound and communicating?

Connect TechView and get into Binding View. This will shut the chiller down. Once in Binding View verify that the Pressure Transducer is bound.

Note: Please refer to Service Tool for questions concerning binding LLIDs and getting into Binding View.

If there are multiple LLIDs that are not verified go to IPC troubleshooting.

If the transducer is not bound, try to bind it. If the transducer will not bind, it could be a problem with the connector or the sensor itself. Take a close look at the connector to make sure that all four wires are securely in place. It may be necessary to remove the cap to check for broken or misplaced wires.

CAUTION Equipment Damage Possible!

All units built before October 1, 2002 (U02#####) used connectors that must be replaced if the cap is removed. If the cap is removed on any of these units cut out the old connector and splice in a new section of cable and a new connector. See Section 2-IPC Overview for instruction on installing a new cap.

If the transducer is bound, try to turn the LED on with a magnet. If the light will not turn on there could be a problem with the transducer. Try to turn the light on in Binding View. With the light on hold the magnet to the LED. The LED should get brighter. If it doesn't get brighter, this may indicate a problem with the transducer or the connector. Take a close look at the connector to make sure that



Pressure Transducers

all four wires are securely in place. It may be necessary to remove the cap to check for broken or misplaced wires.

If there is no problem found with the connector and the transducer will not bind, replace the transducer.

Is the transducer reading accurately?

All transducers are mounted on service valves. Cycle the chiller off prior to testing.

- 1 Close the valve and remove the transducer.
- 2 Connect the transducer, while still connected to the LLID bus, to a nitrogen source with a calibrated gauge.
- 3 The pressure that is applied to the transducer must be steady state. If the pressure is changing the test will not be accurate.
- 4 Increase the pressure on the transducer.
- 5 Monitor the pressure on DynaView or TechView.

The transducer measures in absolute pressure and then subtracts the local atmospheric pressure setting to display gauge pressure. If the local atmospheric pressure is set wrong in TechView, the pressure displayed on DynaView or TechView will not match the gauge pressure. This could result in an inaccurate test.

- 6 If the transducer is not reading accurately it should be replaced.



Variable Speed Fan Control - RTAC Only

The Main Processor (MP) is configurable for operation with either 0, 1 or 2 variable speed fans per circuit. Variable speed fans are optional and included on units when the low ambient operation is required. The variable speed fans are standard fans and motors, used with the fixed speed fans, but are driven by the small 1.5 HP inverters that create a variable voltage/frequency, 3 phase output using Pulse Width Modulation (PWM) switching.

When either 1 or 2 of the variable speed fans are configured, the MP provides startup and running control of the variable speed fans (as well as the other constant speed fans).

Variable speed condenser fans provide start-up and operation down to an ambient temperature of 0° F without fan cycling, without safety trips, or other instabilities that would otherwise occur with fixed speed fans only.

Startup and Operation

The MP provides an output, one per circuit, to control a contactor which delivers 3 phase power to the inverter(s) on that circuit. The output energizes the contactor for the inverter(s) for that circuit at least 5 seconds prior to the first compressor start of that circuit.

Once the compressor(s) on the circuit have started, the inverter(s) will be updated with speed command signals (slaved to run at the same speed if 2 are present), and are continuously monitored for a fault condition. The fan control algorithm outputs a desired % fan capacity for the entire fan deck. This % fan deck capacity is realized by staging on and off constant speed fans in discrete increments of capacity, while the inverter is used to control fan capacity in-between steps.

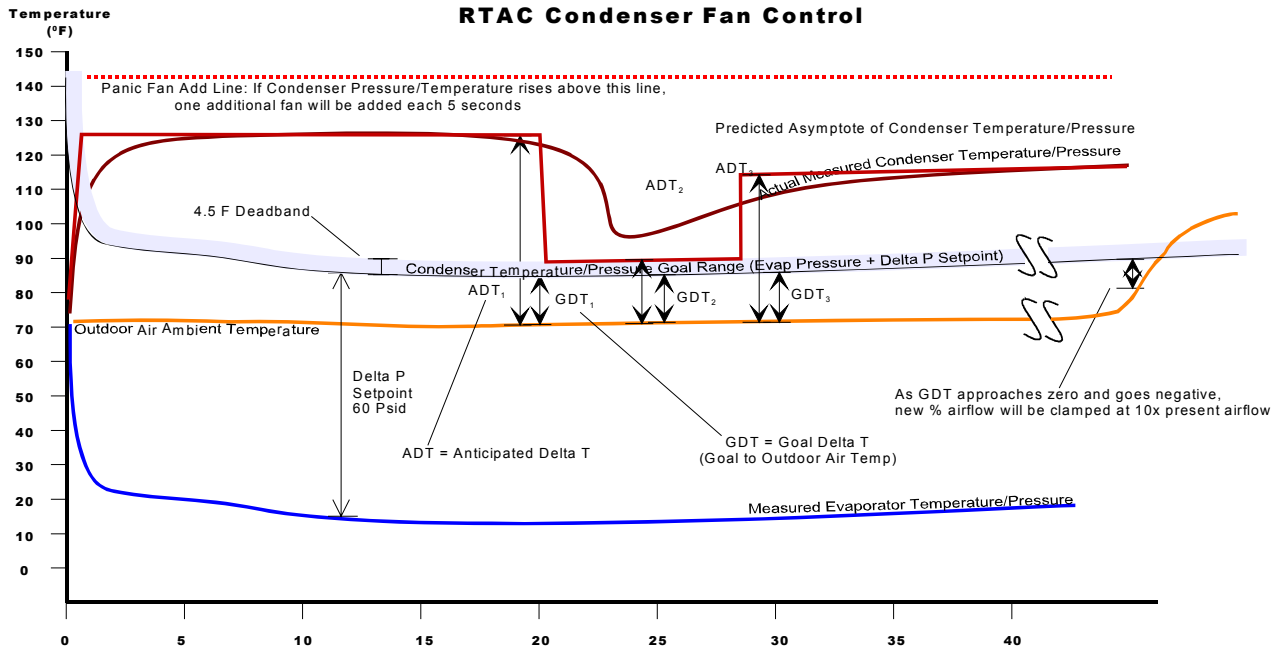


Figure 11. Condenser Fan Control

The fan state is a function of the ambient temperature as sensed by the ambient temperature sensor at startup, times an additional scaling factor that is a function of the lower of either the leaving water temperature or the outdoor air temperature at startup, divided by how many compressors there are per circuit. The maximum number of fixed speed fans that are started are just equal to or less than the Initial Fan Capacity Function per [Figure 11](#). If a variable speed fan is available it will be started along with the necessary number of fixed speed fans to exactly match the requirement.

In normal fan control, a new % fan capacity will be calculated at each iteration per the fan control algorithm. The algorithm attempts to control the fans so that the condenser pressure is held to within a 4.5 F deadband above the condenser goal pressure which is set relative to the current Evaporator Pressure (i.e. 60 PSID above it).

If variable speed fans are present, then the air flow is modulated directly on the Desired New % Air Flow calculated every 5 seconds.

When only fixed speed fans are present, additional fans will not be staged on until the new % Air Flow exceeds the next available fan step.

Inverter Fault Input

The Variable Speed Condenser Fan Inverter provides a fault indication to the MP through an optically isolated darlington transistor circuit. The transistor is off when the inverter is un-powered or in the fault state, and is on at all times during normal operation. A fault signal is sent by the inverter if it has gone through a self shutdown or if the output frequency of the inverter is limited to less than 50% of the signal speed commanded by the MP. Upon receipt of the fault signal (high voltage at fault input terminals), the MP attempts to reset the fault by sending a 0 PWM command to the inverter for a total of 5 seconds. The fault signal again checks and will be repeated if still in fault. If four faults are detected within 1 minute of each other, the power to the inverter cycles off for 30 seconds (through contactor control) and then re-powered. If the fault still remains or occurs again within 1 minute, a diagnostic is called out, the MP shuts off the Inverter, and attempts to run the remaining constant speed fans using the normal constant speed Fan Control Algorithm. When 2 inverters are configured on a circuit, the fault responses are directed to both of the inverters on that circuit. The only exception is that the diagnostic specifies which inverter of the pair reported the fault.

Troubleshooting the Inverter

The purpose of this troubleshooting section is to help technicians determine if the variable speed fan inverter, the compressor module, the fan contactor, the fan motor, or the interconnecting wiring is faulty.

⚠ WARNING **Live Electrical** **Components!**

During installation, testing, servicing and troubleshooting of this product, it may be necessary to work with live electrical components. Have a qualified licensed electrician or other individual who has been properly trained in handling live electrical components perform these tasks. Failure to follow all electrical safety precautions when exposed to live electrical components could result in death or serious injury.

⚠ WARNING **Hazardous** **Voltage!**

The VFD's have large capacitors that can store high voltage even when denergized. Once denergized the capacitor may take 1 minute to completely discharge. Always wait for at least 1 minute before servicing the VFD to insure the capacitors are completely discharged. The green status LED will turn off when the capacitor has discharged. Failure to follow these instructions could result in death or serious injury.

Status Indication on the VFD

Two LED's are provided for drive status indication. One green Power LED lights when power is applied to the unit. The other red Alarm LED lights in the event of a pending overload or flashes in the event of a fault for the first minute after the fault occurs.

Power On LED. This green LED is illuminated any time that more than 50 VDC is present on the DC Bus Capacitors. Typically when power is removed from the



Variable Speed Fan Control - RTAC Only

TRANEAC INVERTER this LED will remain illuminated for up to 60 seconds while the DC Bus Capacitor Voltage discharges. This LED also indicates that the 5 VDC Supply Voltage on the TRANE AC INVERTER control board is present.

Alarm LED. When this red LED is illuminated constantly, it indicates that the motor is overloaded and the drive is about to fault on a motor overload. When the Alarm LED is flashing, it indicates the drive is faulted. By counting the number of times the Alarm LED flashes, the cause of the fault can be determined. The following table lists the possible fault conditions.

Table 3. VFD Fault Conditions

Fault Condition	Number of Alarm LED flashes Bus
Overcurrent Fault	1
Bus Overvoltage Fault	2
Motor Overload Fault	3
Low Bus Voltage Fault	4
PWM Generator Fault	5
Logic Fault	6
Stalled Motor Fault	7

In this troubleshooting procedure, the components will be referred to by the following descriptions:

Table 4. VFD Components

Description	Circuit 1		Circuit 2	
	1 Comp	2 Comp	1 Comp	2 Comp
Variable Speed Fan Inverter	3U3	3U3, 3U4	4U3	4U3, 4U4
Dual Inverter Interface LLID	1U3	1U3	1U3 or 2U3	2U3
Fan Motor	3B3	3B3, 3B13	4B3	4B3,4B13
Fan Fuses	1F1, 1F2, 1F3 (All Voltages)	1F1, 1F2, 1F3 (All Voltages)	1F2, 1F8, 1F9 (All Voltages)	2F7, 2F8, 2F9 (All Voltages)
	1F17, 1F18, 119 (380, 400, 460, 575 Volt only)	1F17, 1F18, 1F9 1F20, 1F21, 1F22 (380, 400, 460, 575 Volt only)	1F20, 1F21, 1F22 (380, 400, 460, 575 Volt only)	2F17, 2F18, 2F9 2F20, 2F21, 2F22 (380, 400, 460, 575 Volt only)

- Using TechView, go into the Unit Configuration View and verify the Low Ambient Capacity Condenser is selected for Condenser Temperature Range. This will also be reflected as an L or W in digit 17 of the model number. Go into Binding View and verify that the fan control LLIDs are bound.
- Verify that all inverter power and control signal wiring is correct for the affected circuit. The wiring diagrams are found in RTAC-SVX01C-EN or on the inside of the unit fan control door.

Variable Speed Fan Control - RTAC Only

- 3 Attempt to start the compressor on the desired circuit. Thirty seconds prior to compressor start, the variable speed fan inverter contactor is energized. Be sure that you can hear the fan contactor pull in. If not, attach an AC voltmeter from FR to ground on the Dual Inverter Interface LLID. Reset the control and look for a 115 volt reading on the voltmeter at FR, 25 to 30 seconds prior to compressor start. If this 115 volts is verified but the contactor does not pull in, check for an open circuit in the contactor coil or an open circuit in the interconnecting wiring to the contactor.
- 4 Check the fan motor by completely bypassing the inverter. Disconnect power from the chiller and remove the three-phase power wiring from the inverter. Connect it to the three-phase power wiring of the fan motor. Re-apply power to the unit and reset the circuit being tested. Make sure the phasing is proper when reconnecting the inverter. Twenty-five or thirty seconds before the compressor starts, the contactor that would normally apply power to the inverter should pull in and the fan should run. If the fan does not run, check the line fuses and contactor contacts.

The fan will only run for approximately 30 seconds before the inverter fault will cause the contactor to drop out.

- 5 Disconnect power from the unit and reconnect the inverter module. At the same time, check for damaged wiring or loose quick connects on the inverter.
- 6 Remove connector P1 or P2 (whichever applies) from the inverter and place a jumper wire between terminals F and FR on the female connector. See [Figure 12](#) for the location of these wires. This will prevent the control from reporting a fault diagnostic. Restart the unit and carefully measure the DC voltage between wires C (+) and CR (-) on the same female connector. The voltage should be 2 to 10 VDC when the compressor on the affected circuit is running. At compressor start, this voltage will be approximately 2 VDC and gradually ramp up to about 10 VDC. This voltage level is directly proportional to fan speed. At 5 VDC, the fan should be running at 50% of full speed and at 7 VDC the fan should be running at 70% of full speed.

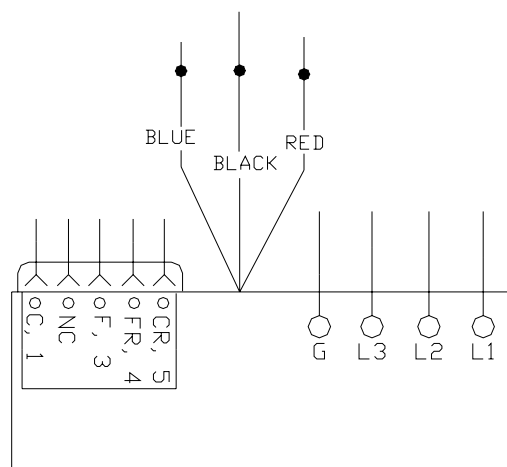


Figure 12. Variable Speed Fan Inverter



Variable Speed Fan Control - RTAC Only

Note: The output from the compressor LLID is a pulse width modulated signal, 10 volt peak and 10 Hz. fundamental. Its average value can be read with a DC voltmeter.

- 7 Remove the jumper wire and reconnect connector P1 or P2. While the inverter is still powered, measure the DC voltage between pins F (+) and FR (-) on the Dual Inverter Interface LLID. The connector must be plugged on at both ends while measuring this voltage. If the reading is between 11.5 and 12.5 VDC two problems may exist:
 - a The inverter indicates that it has a fault by opening a semiconductor switch within the inverter. The inverter sends a fault signal to the MP when:
 - It has gone through a self-shutdown. One cause of this could be high line voltage. A 10% high line voltage could cause a diagnostic trip.
 - The output frequency of the inverter is being internally limited to less than 50% of the signal speed commanded by the MP. Excessive fan motor current, high temperature or internal inverter failures could cause this to occur.
 - b There is an open circuit in the fault signal wiring, somewhere between the inverter and the compressor module.

If the reading is 2 VDC or less between F and FR, an inverter fault diagnostic for the affected circuit should not be displayed. If the variable speed fan is still not working, check these two interconnecting wires from the compressor module to the inverter, to be sure they are not shorted. The inverter cannot send the Dual Inverter Interface LLID a fault signal if these two wires are shorted together.

- 8 If all the settings and voltages through step 7 are acceptable and the fan does not operate, replace the variable speed fan inverter.



Current Transformers

Each compressor motor has all three of its line currents monitored by toroid (doughnut) current transformers. These currents are normalized with respect to the Rated Load Amps of the respective compressor and thus are expressed in terms of % RLA and in Amps. The currents are “normalized” through the proper selection of the Current Transformer and the unit configuration. CTs are selected based on the motor RLA. Refer to [Table 5](#).

The current transformers provide the input for five basic functions of the starter module:

- 1 Current overload protection using a programmed % of Rated Load Amps versus time to trip characteristic. The steady state “must trip” value is 140% RLA and the “must hold” value is 125% RLA. The starter Module will trip out the compressor, and the Main Processor (MP) will then shut down the other compressor on the same refrigerant circuit (if applicable). The appropriate diagnostic codes will be displayed.
- 2 Loss of Phase Current. A phase loss due specifically to lack of Current Transformer inputs is not looked for during transition (which lasts for 3 seconds in software) and is additionally delayed 2.8 seconds. As such, the diagnostic will not be called out any sooner than 5.8 seconds after transition even if it occurs immediately at start. Additionally, two of the three current inputs also serve the Phase Rotation circuits. If this circuit (monitored immediately after start), outputs an inconsistent value to the module (due to loss of one or both of its inputs), a diagnostic of either Phase Loss (steady output) or Phase Reversal Protection Lost (varying output) will occur with a maximum delay of 1.2 seconds after start.
- 3 Phase Rotation. Screw compressors cannot be allowed to run in reverse direction. To protect the compressors, the phase rotation is detected by the current transformers immediately at start up. If improper phasing is detected, within 1 second of startup, the Starter Module will trip out the compressor, and the MP will then shut down the other compressor on the same refrigerant circuit (if applicable). The Phase Rotation diagnostic codes will be displayed. Phase Rotation is only active for the first second of operation.
- 4 Phase Unbalance. The Starter Module will shut down the compressor if a phase current unbalance is detected by the current transformers while the compressor is running. A 30% unbalance will cause the Starter Module to trip out the compressor, and the MP will then shut down the other compressor on the same refrigeration circuit (if applicable). Phase unbalance is based on the following calculation:

$$\% \text{ unbalance} = \frac{(I_{0x} - I_{ave}) \times 100}{I_{ave}}$$

Where:

$$I_{ave} = \frac{I_{01} + I_{02} + I_{03}}{3}$$

I_{0x} = the phase with the largest difference from I_{ave} .

- 5 Current Limit. The current limit range for each compressor is 60-120% RLA for RTAC and 40-100% RLA for RTHD. The figure below provides a graphical illustration of the current limit control.

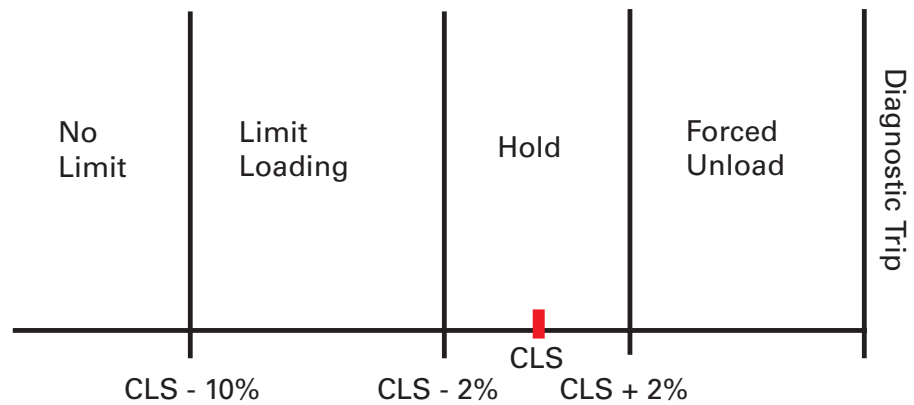


Figure 13 Current Limit Control

Note: The current transformers are NOT polarity or directionally sensitive in RTAC and RTHD applications

CT and Starter Compressor Current Input Checkout Procedure

⚠ WARNING Live Electrical Components!

During installation, testing, servicing and troubleshooting of this product, it may be necessary to work with live electrical components. Have a qualified licensed electrician or other individual who has been properly trained in handling live electrical components perform these tasks. Failure to follow all electrical safety precautions when exposed to live electrical components could result in death or serious injury.

- 1 Check incoming 3-phase power for voltage within +/- 10% of nominal per Chiller nameplate. Verify that unit size and voltage are set correctly using TechView.
- 2 Check for all of the active diagnostic codes or the historic diagnostic codes using TechView under Diagnostic View.

If there is any question as to which compressor or current transformer is causing a problem, or simply to verify and "witness" the problem, an attempt should be made to start the chiller after resetting all diagnostics.

It is possible to "force" specific compressors to be the first or next compressor to stage on, using the "Compressor Test" feature of Tech View in Compressor Service View. The Leaving Water Temperature must, however, be



Current Transformers

above the Chilled Water Setpoint by more than the “differential to start” setting, in order to stage on the first compressor.

At startup, verify the appropriate contactor(s) pull-in. The starting compressor can be determined in TechView. The mode will change from stopped to starting. This can also be seen on the DynaView under the Modes tab. Note the diagnostic(s) that results, then place the Chiller into the “Stop” mode.

- 3 For the next portion of the procedure, pull the unit's disconnect and interrupt all high voltage power to the control panel. Locate the toroid (doughnut) current transformers encircling the compressor power wiring and branching to the compressor contactors of the suspect compressor in the control panel. Refer to the Component Location Drawing in the panel to identify the particular current transformer(s) of interest. Locate the part number/UL tag on the transformer leads and note the Trane part number which identifies the transformers.
- 4 Utilizing the Schematic Wiring Diagram, locate the termination of the transformer's wiring into the Phoenix plug at the appropriate Starter module at pin header J7. Pull off the appropriate Phoenix connector from the pin header on the Starter.

CAUTION Equipment Damage!

Current Transformers can be damaged and high voltages can result due to running the compressors without a suitable burden load for the CTs. This load is provided by the Starter input. Take care to properly reconnect the CT's Phoenix connector prior to attempted start of the compressors.

- 5 Using a digital volt-ohmmeter, measure the resistance of the transformer(s) by probing the appropriate pair(s) of receptacles within the Phoenix connector. The receptacle pairs of the Phoenix connector are most easily measured by using meter leads with pointed probes and contacting the exposed metal of the connector through the top Phoenix connector.
- 6 Refer to [Table 5](#) which lists the normal resistance range for each extension of current transformer. Check the measured resistance against the value listed per transformer extension. If the resistance is within tolerance, the transformer and Phoenix connector can be considered good. Go on to step 8.

Table 5. Current Transformers Rating and Resistance

Unit RLA	Part Number	Rating (amps)	Usable Range (amps)	Resistance Ohms (+10%)
67-100	X13580269-01	100	66.67-100	23.5
100-150	X13580269-02	150	100-150	35.0
134-200	X13580269-03	200	134-200	46.0
184-275	X13580269-04	275	184-275	67.0
267-400	X13580269-05	400	267-400	68.0
334-500	X13580269-06	500	334-500	89.0
467-700	X13580269-07	700	467-700	128.0
667-1000	X13580269-08	1000	667-1000	235.0
33.4-50	X13580269-09	50	33.37-50	11.5
50-75	X13580269-10	75	50-75	17.0

- 7 If the resistance reading above is out of tolerance, the problem is either with the transformer, its wiring, or the Phoenix connector. First, double check the schematic to be sure you are working the proper lead pair. Then, check the CT resistance at the CT.

More than one current transformer is terminated to a single Phoenix connector. When replacing, take care to note the proper positions of the respective transformer wire terminations on the Phoenix connector for re-termination. (The current transformers are NOT polarity or directionally sensitive). The transformer lead wiring is #16 ga, UL 1015 600V and the proper Phoenix connector must be used to ensure a reliable connection. Isolate the problem to the current transformer or its wiring apart from the connector.

- 8 If the transformer/connector resistance proves accurate, recheck the resistance with the connector held at different angles and with a light lead pull (less than 5 lb.) to test for an intermittent condition.
- 9 To perform the following test, you will need to use a digital voltmeter with a diode test function. With the transformer Phoenix connector disconnected and the power off to the Starter, perform a diode test across the corresponding pair of current transformer input pins on the Starter (header J7). The meter should read from 1.0 to 1.5 volts for each current transformer input. Repeat using the opposite polarity. The same reading should result. Extreme errors suggest a defective Starter module. If the diode voltage drops prove accurate, reconnect the transformers to the Starter and re-power the unit.

⚠ WARNING
Live Electrical
Components!

During installation, testing, servicing and troubleshooting of this product, it may be necessary to work with live electrical components. Have a qualified licensed electrician or other individual who has been properly trained in handling live electrical components perform these tasks. Failure to follow all electrical safety precautions when exposed to live electrical components could result in death or serious injury.

- 10 With the CTs reconnected to the Starter, attempt a restart of the chiller. As the given compressor is started, and the inrush locked rotor transient has passed, (locked rotor transient should last less than one second) simultaneously monitor the actual compressor phase current(s) (using a clamp- on type ammeter) and the voltage developed at the respective current transformer's termination at the Starter (using a digital volt-meter on a 0-20 VAC scale). Refer to [Table 5](#) for the compressor phase current to output voltage relationship for each extension current transformer. Using [Table 5](#), look up the current that corresponds to the output voltage read by the voltmeter and compare to ammeter reading. Assuming relatively accurate meters, the values should agree to within $\pm 5\%$.
- 11 If the measured current and the output voltage from the CT agree within the tolerance specified, the CT is good. If diagnostics, overload trips, or other problems potentially involving current sensing continue to occur with all phase currents to the compressors verified to be within their normal range, then the problem is with the Starter Model's current input. It is advisable to replace the Starter module at this point.



Over/Under Voltage

The under/over voltage protection is an optional configuration for RTHD and standard for RTAC. The input voltage for the Optional Under/Over Voltage Transformers will be supplied from the incoming (line side of the starter contactors) three phase power connections to the unit. The secondary or these transformer(s) are connected to the Starter module.

Over Voltage: Trip: 60 seconds at greater than 112.5%, $\pm 2.5\%$, Auto Reset at 109% or less.

Under Voltage: Trip: 60 seconds at less than 87.5%, $\pm 2.8\%$ at 200V or $\pm 1.8\%$ at 575V, Auto Reset at 90% or greater.

RTAC Chillers

CH530 monitors one line to line voltage for the entire chiller. Regardless of how many compressors, power supply disconnects or power terminations or starter panels are on the unit, the design uses a single Potential Transformer of Phases L1 to L2(Vab) wired just upstream of the contactor for compressor 1A. Under / Over voltage protection is based solely on this voltage. The transformers will display the magnitude of these voltages as well as provide under and over voltage protection, if it is enabled.

Check out procedure for RTAC

⚠ WARNING Live Electrical Components!

During installation, testing, servicing and troubleshooting of this product, it may be necessary to work with live electrical components. Have a qualified licensed electrician or other individual who has been properly trained in handling live electrical components perform these tasks. Failure to follow all electrical safety precautions when exposed to live electrical components could result in death or serious injury.

Under/Over Voltage Transformer Checkout

- 1 Locate the Under/Over Voltage Transformer 1T9 in the panel by referring to the Component Location Drawing. Carefully measure and record the primary voltage across the Transformer (Line Voltage Phase A to B).
- 2 Next, disconnect the transformer's secondary from J5 on the Starter module. Using voltmeter probes, measure and note the unloaded secondary voltage (Vac rms).
- 3 The ratio of the primary or line voltage to the open circuit secondary voltage should be 20 to 1. If the unloaded turns ratio is not within 2% of this value, replace the transformer.
- 4 Reconnect the secondary back to J5 and measure the loaded (connected) secondary voltage. The new loaded ratio should be approximately 20.2 to 1. If not within 2% of this ratio, the transformer's secondary should be disconnected from the Starter module and a 1000 Ohm resistor connected



Over/Under Voltage

across the secondary. Measuring the voltage across the 1000 Ohm resistor should yield a voltage ratio of 20 to 1. Deviations of more than $\pm 2\%$ suggests a bad transformer. If the 1000 Ohm loaded ratio is within tolerance, but the Main Processor connected ratio is out of tolerance, suspect a bad Starter Module. Before replacing the Starter module, double check the Unit Line Voltage programed in the Main Processor. It should match the nameplate unit line voltage.

- 5 If the Under/Over Voltage Protection continues to call out a diagnostic and all of the above measured ratios are within tolerance, and all Main Processor Under/Over Voltage settings have been verified, replace the Starter module.

RTHD Chillers

CH530 will monitor all three line-to-line voltages for the chiller, Vab, Vbc and Vca. Both the over and the under voltage diagnostics will be based on the average of the three voltages. The transformers will display of the magnitude of these voltages as well as under and over voltage protection, if such is enabled.

Check out procedure for RTHD

⚠ WARNING
Live Electrical
Components!

During installation, testing, servicing and troubleshooting of this product, it may be necessary to work with live electrical components. Have a qualified licensed electrician or other individual who has been properly trained in handling live electrical components perform these tasks. Failure to follow all electrical safety precautions when exposed to live electrical components could result in death or serious injury.

Potential Transformer

The following table shows the conversion of input voltages as measured at the voltage inputs of the Starter module to the incoming line-to-line voltage the transformers are connected to. The potential transformer has a turn's ratio of 600:30.

Table 6. Starter Module Input-to-Line Voltage Conversion

Starter Module Input Voltage J5-1,2 J5-3,4 J5-5,6 (Volt AC)	Incoming Line-to-Line Voltage (Volt AC)
9.4	190
9.9	200
10.4	210
10.9	220
11.4	230
11.9	240
12.4	250
12.9	260
13.4	270
13.9	280



Over/Under Voltage

Table 6. Starter Module Input-to-Line Voltage Conversion

Starter Module Input Voltage J5-1,2 J5-3,4 J5-5,6 (Volt AC)	Incoming Line-to-Line Voltage (Volt AC)
14.4	290
14.9	300
15.4	310
15.9	320
16.3	330
16.8	340
17.3	350
17.8	360
18.3	370
18.8	380
19.3	390
19.8	400
20.3	410
20.8	420
21.3	430
21.8	440
22.3	450
22.8	460
23.3	470
23.8	480
24.3	490
24.8	500
25.3	510
25.7	520
26.2	530
26.7	540
27.2	550
27.7	560
28.2	570

Acceptable tolerance between actual incoming line-to-line voltage and displayed voltage (on DynaView or TechView) is $\pm 3\%$ of reading. The accuracy of the meter being used to measure the actual line-to-line voltage needs to be added to this tolerance.

Acceptable tolerance between the Starter module input voltage measurements listed [Table 6](#) with respect to the displayed line-to line voltage (on DynaView or TechView) is $\pm 3\%$ of reading.



Over/Under Voltage

Starter Module

- 1 Switch the line power off and run a separate 120 VAC control power to the chiller controls. With the controls powered up (Chiller mode set to Stop), measure the common mode input voltages to the Starter module as VDC and verify they fall within the following:

Table 7. Starter Module Potential Transformer Input DC Voltages

Starter Module Input Terminals	Minimum Acceptable DC Voltage(VDC)	Maximum Acceptable DC Voltage(VDC)
J5-1 with respect to ground	+2.45	+2.55
J5-2 with respect to ground	+2.45	+2.55
J5-3 with respect to ground	+2.45	+2.55
J5-4 with respect to ground	+2.45	+2.55
J5-5 with respect to ground	+2.45	+2.55
J5-6 with respect to ground	+2.45	+2.55

- 2 If any of the voltages are not within the acceptable range listed in Appendix A Table 2, then disconnect all the external wires to the J5-1 to 6 terminals. Again measure the voltages in [Table 7](#).

If the voltages all fall within the acceptable range, then there is most likely an error in the external wiring to the Starter module potential transformer inputs. This includes the potential transformers themselves.

If any voltage is not within the acceptable range, then there is most likely a problem with installation of the Starter module or with the Starter module itself. Check the four wire LLIDs bus connection to the Starter module. Check the 24 +/- 2.4 VDC power supply input. Insure the Starter module is grounded via the mounting screws. If installation is correct, replace the Starter module.



Starter

CH530 provides compatibility with two types of starters for RTAC and RTHD

- X-Line - RTAC only
- Y-Delta
- Solid State - RTHD only

X-Line

CH530 provides a "Start" contact closure output for across the line starters. To reduce the risk of starter damage due to the wrong starter type being selected, the Transition Complete input is required to be wired at the starter module.

Y-Delta

Individual relays on the CH530 Starter module control the timing sequence for the "Stop", "Start", "Short", "Transition", and "Run" contactor closures. During a motor start. Prior to closing the "Short" contact, the transition complete input is verified to be open, otherwise an MMR diagnostic is generated.

The sequence of a Y-Delta Start is shown in [Figure 14](#). A more elaborate description of the Y-delta starting sequence is shown in [Figure 15](#) -[Figure 28](#).

Starting Wye Delta With Contactor Integrity Test

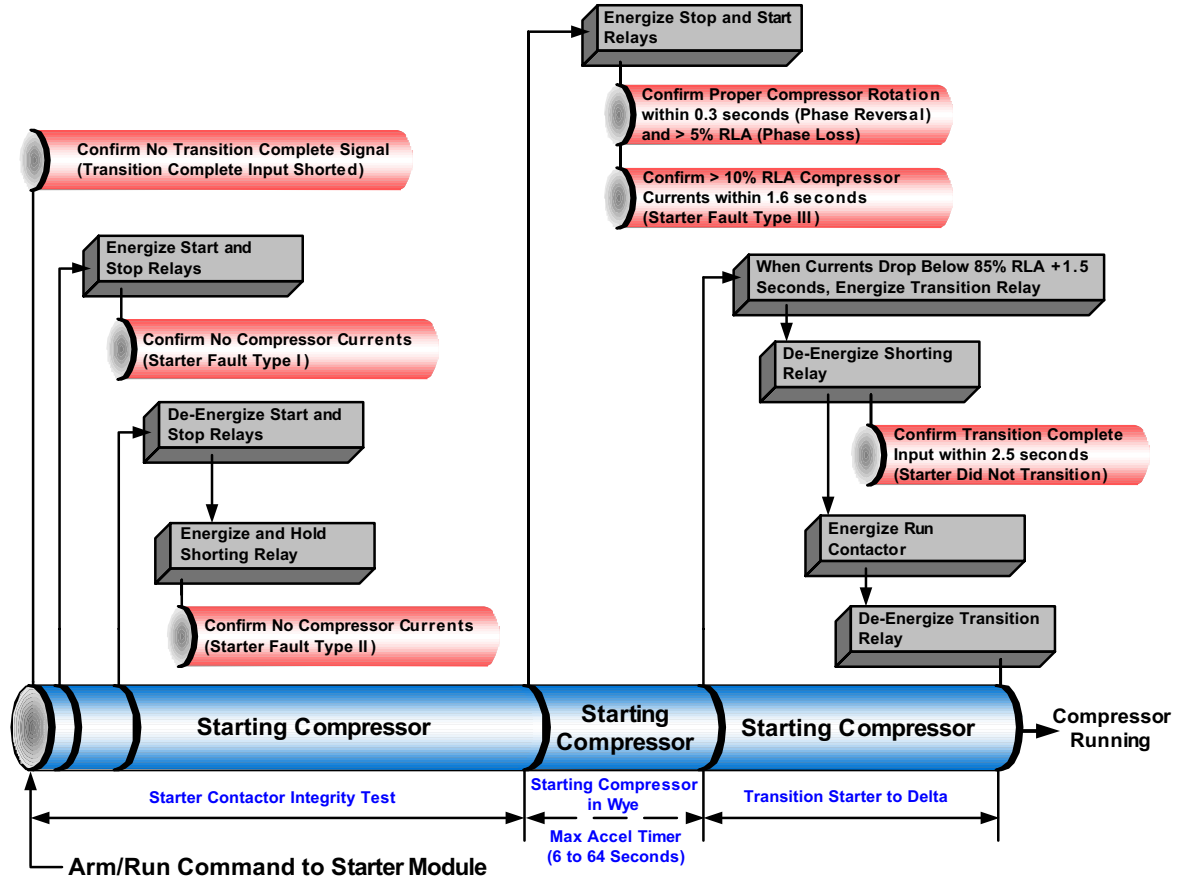


Figure 14. Sequence of Operation Y-delta Start

YDelta Starter Sequence

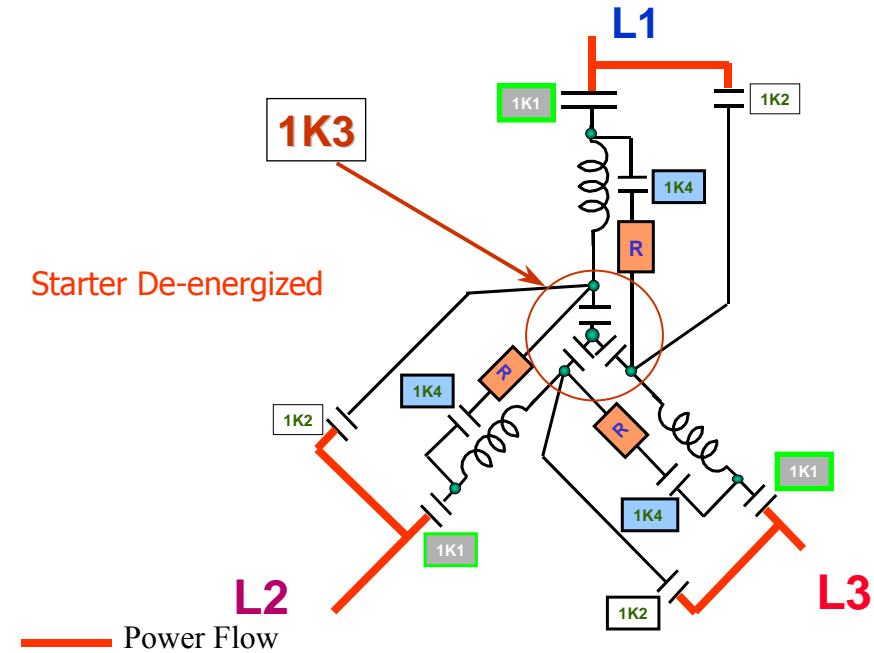


Figure 15. Y-Delta Starter Sequence

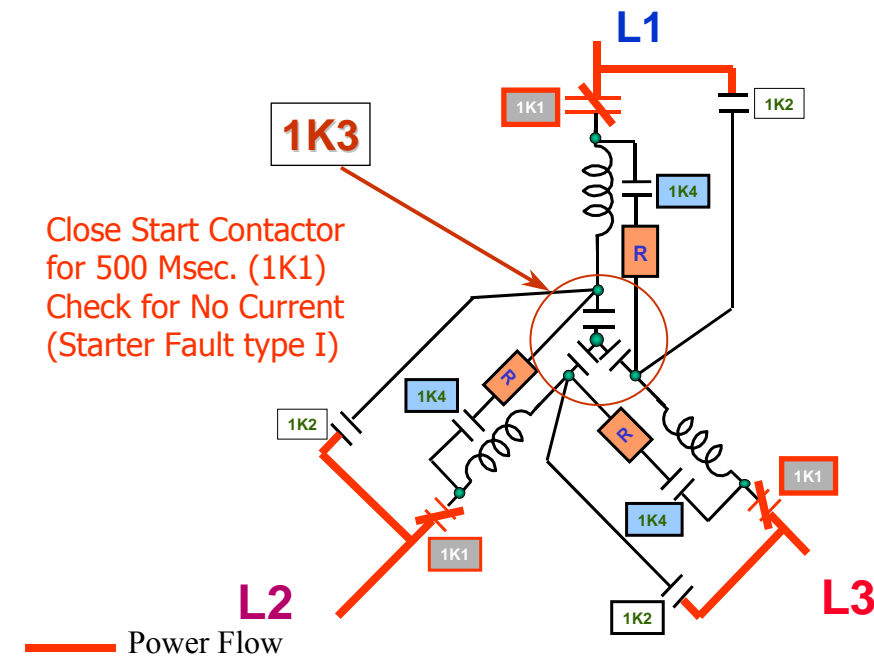
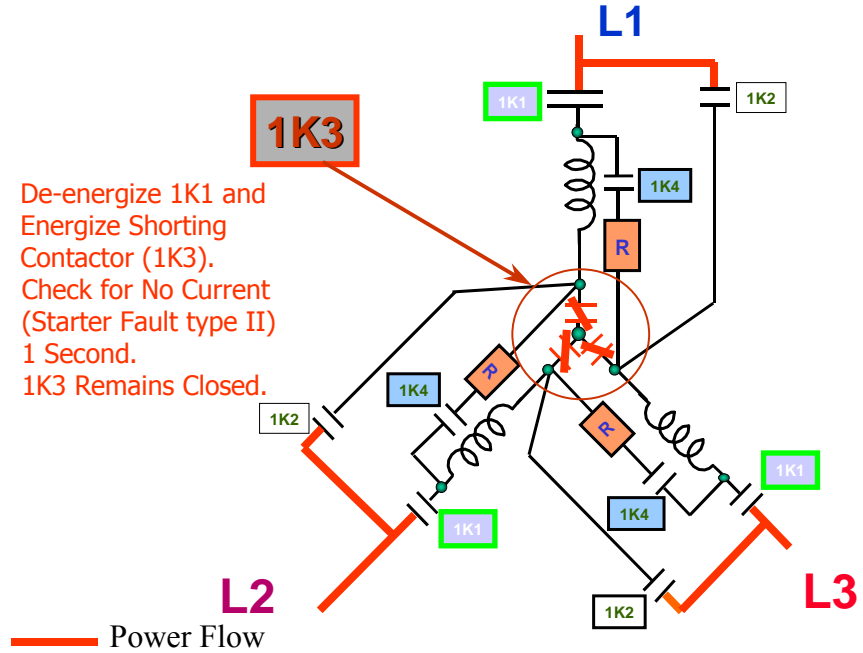
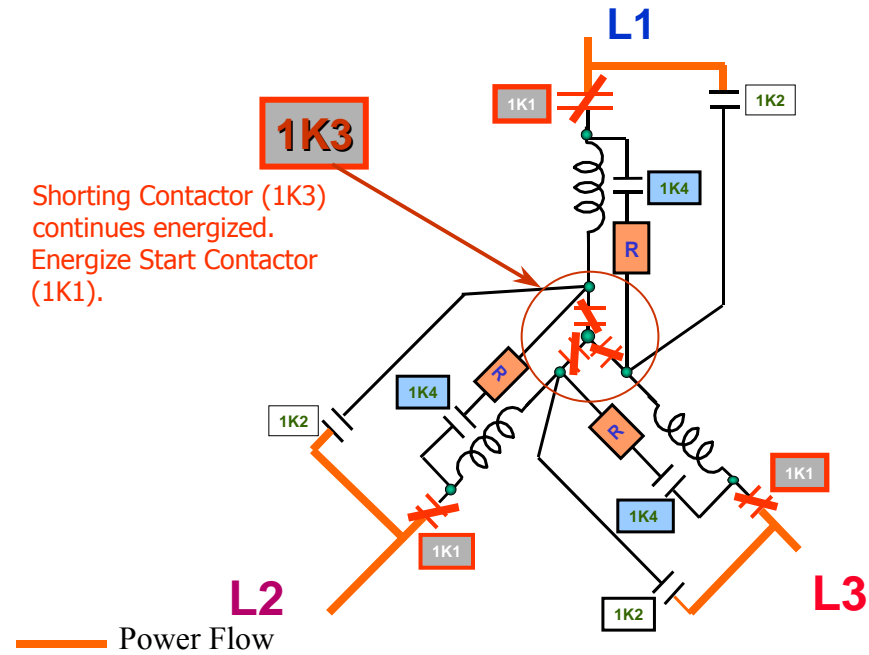
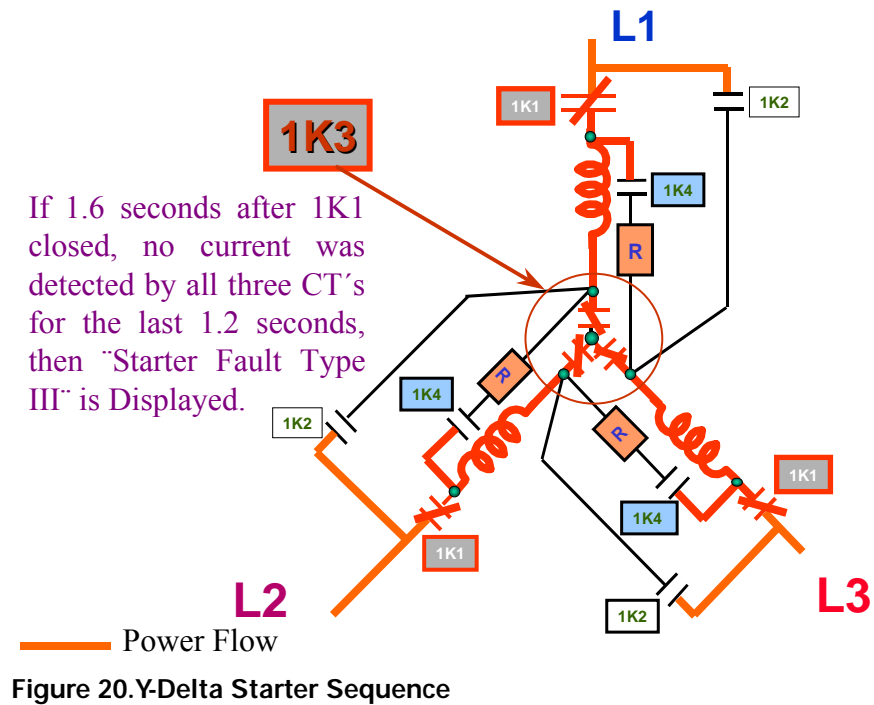
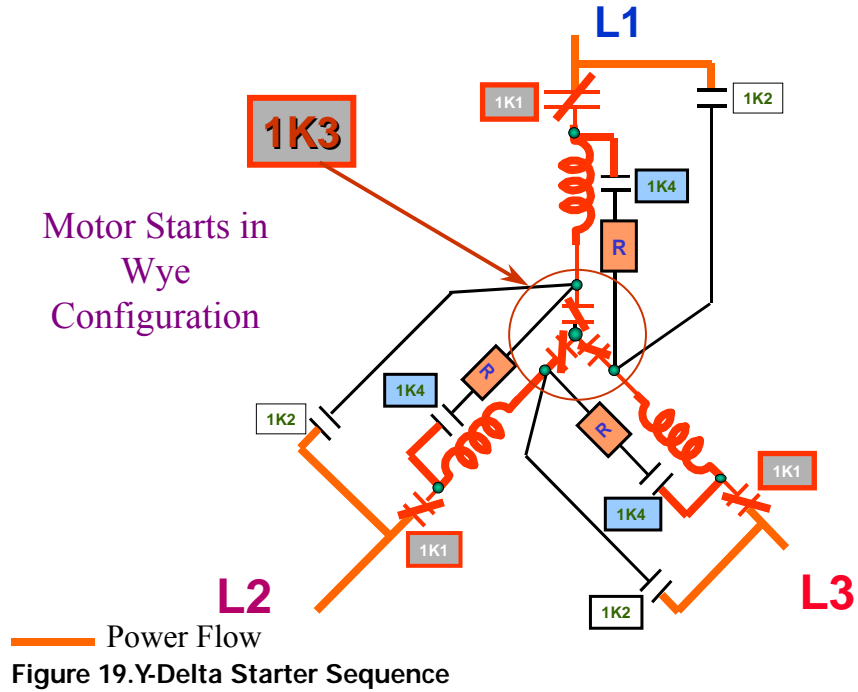
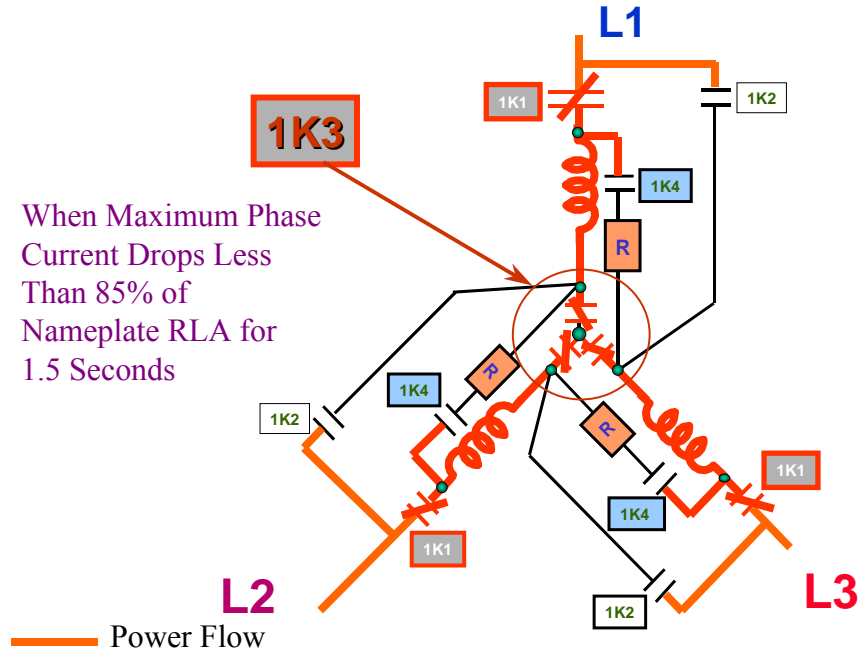
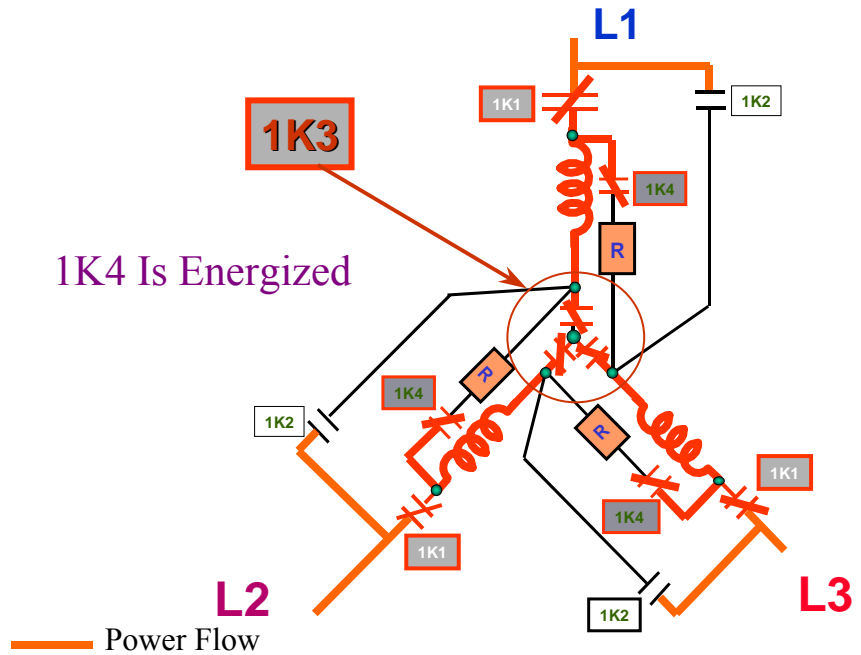
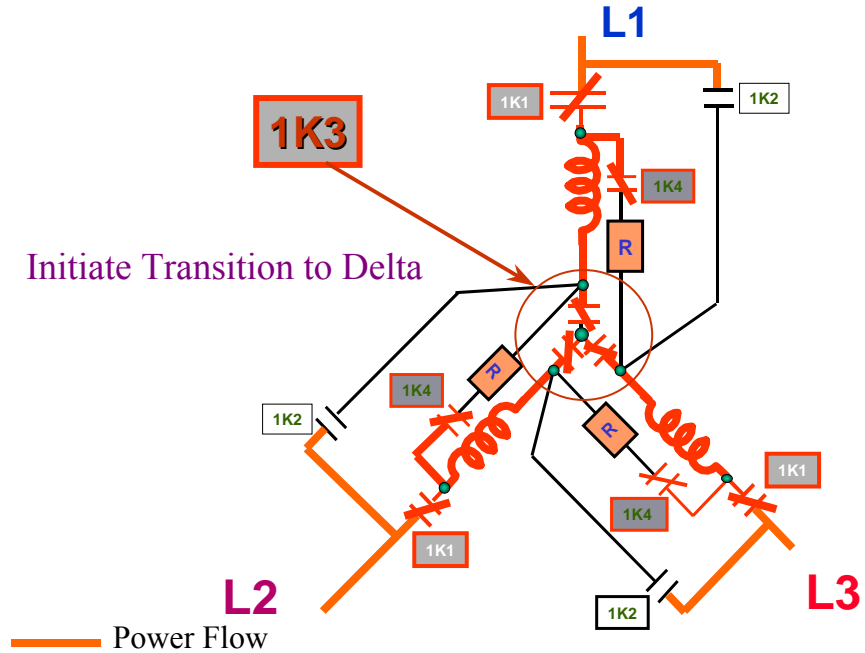
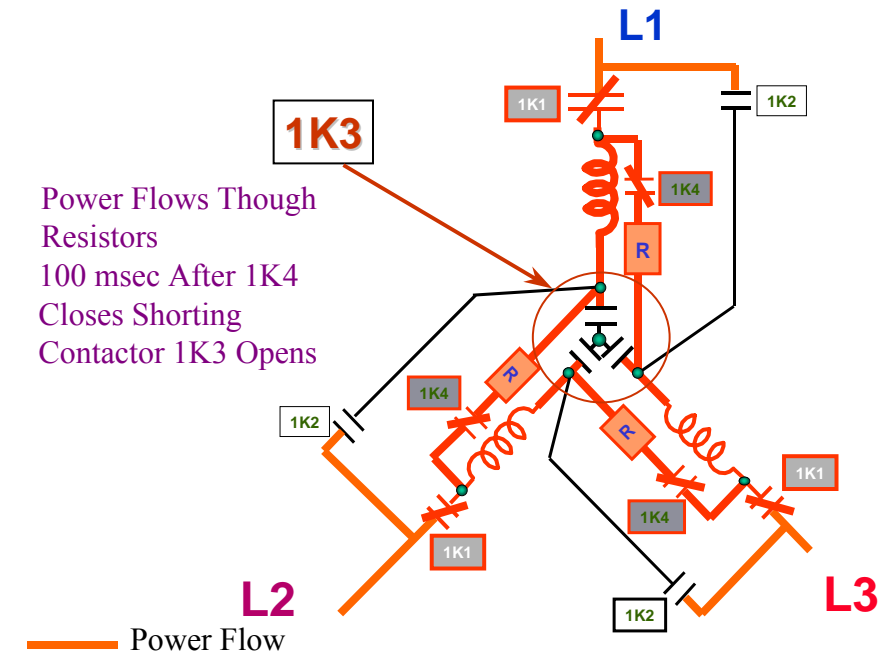


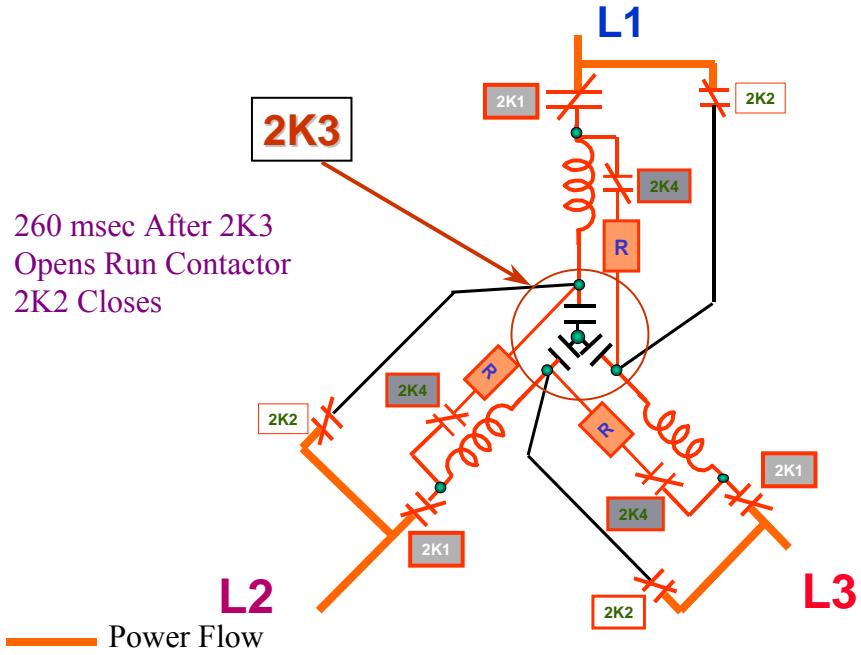
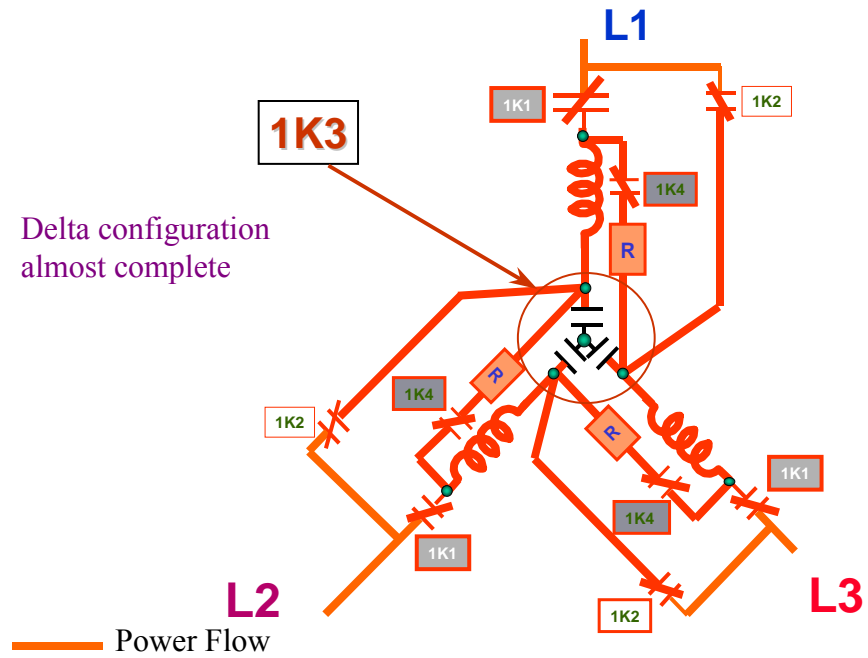
Figure 16. Y-Delta Starter Sequence

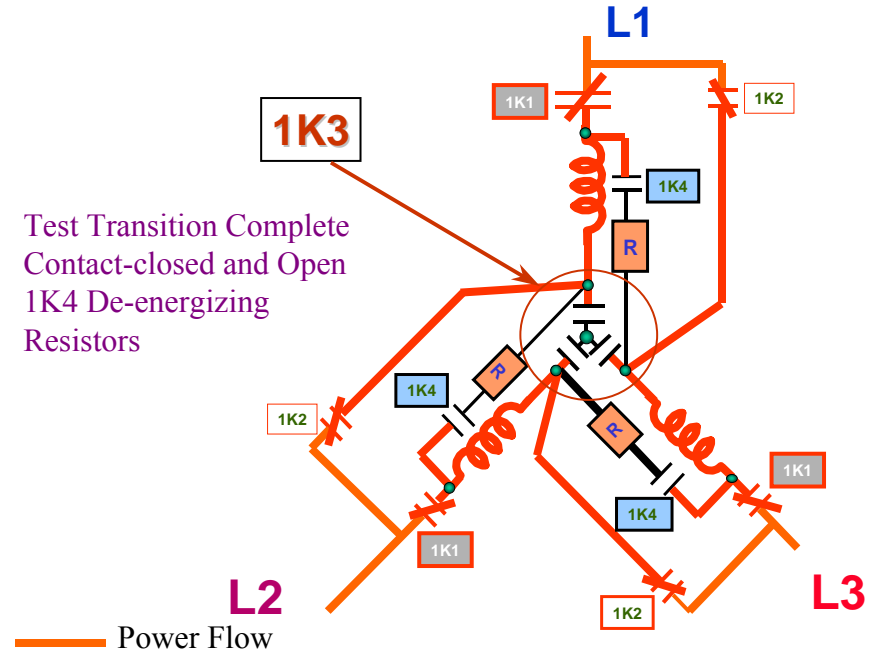
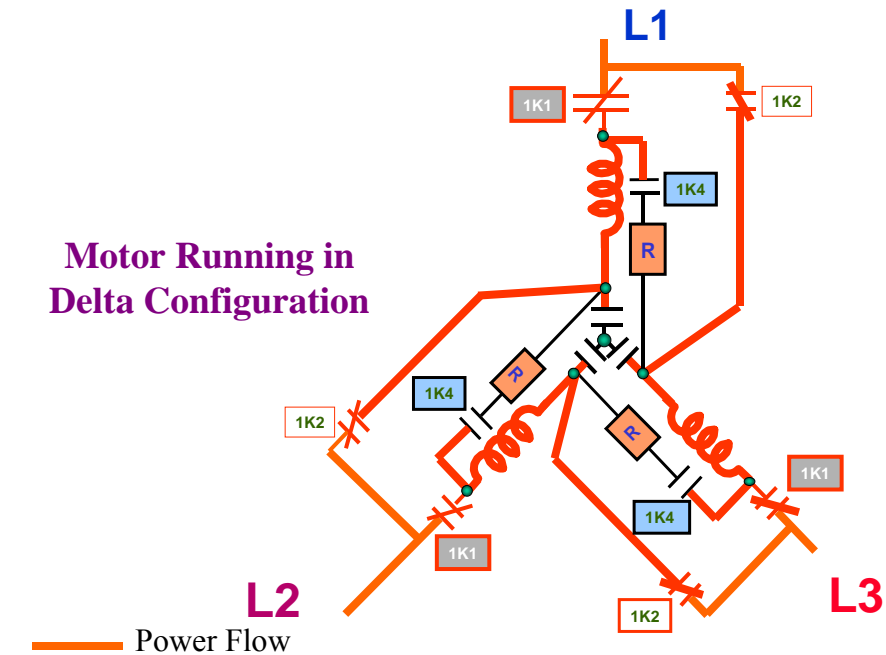

Figure 17.Y-Delta Starter Sequence

Figure 18.Y-Delta Starter Sequence




Figure 21.Y-Delta Starter Sequence

Figure 22.Y-Delta Starter Sequence


Figure 23.Y-Delta Starter Sequence

Figure 24.Y-Delta Starter Sequence


Figure 25.Y-Delta Starter Sequence

Figure 26.Y-Delta Starter Sequence


Figure 27.Y-Delta Starter Sequence

Figure 28.Y-Delta Starter Sequence

Solid State - RTHD Only

CH530 provides an interface with Non-Communicating Solid State Starter.

The following points of interface are provided.

Start contact closure output: This contact closure output will be closed when the compressor motor is to run and opened when the compressor motor is not to run. This output will be latched to prevent chatter of this command to the starter

Up To Speed contact closure input: This contact closure input is closed when the solid state starter has started and accelerated the compressor motor. Failure of this input to close within the maximum acceleration time will cause the "Motor Failed to Accelerate" diagnostic to be called out.

Starter Fault contact closure input: This high voltage binary input will be open when the solid state starter system is not powered and when the solid state starter has an active fault. It will be high voltage (115 VAC) during normal operation of the solid state starter. This input shall be ignored for five seconds following power-up. After the first five seconds, if this input voltage is high, a Starter Fault diagnostic shall be called out.

The sequence of a Solid State Start is shown in [Figure 29](#)

Refer to RTHD-SVD01A-EN for IT Solid State Starter Troubleshooting.

Refer to RTHD-SVD02A-EN for RediStart Solid State Starter Troubleshooting.

RTHD Sequence of Operation: Starting Non-Communicating Solid State Starter

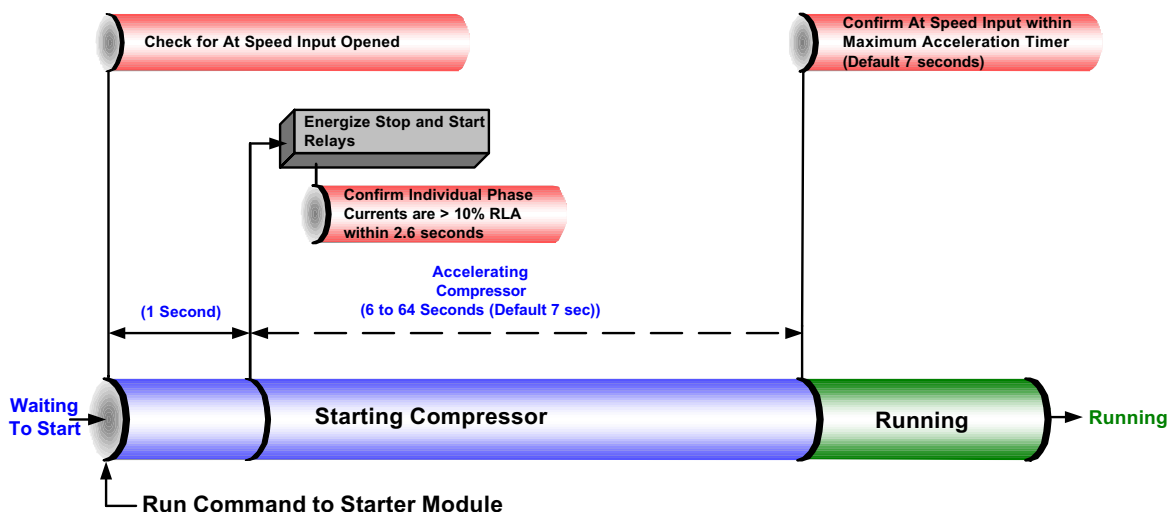


Figure 29.RTHD Sequence of Operation Solid State Start

Compressor Capacity - RTHD

The CHHC compressor is a "screw" or helical rotor design with two rotors, one directly driven by the motor called the male and the other driven by the gears of the male called the female. Design improvements from the original RTHB compressor family were made to accommodate refrigerant 134a.

The RTHD compressor varies its capacity with a slide valve. The slide valve is located internal to the compressor and directly controls the compressor's capacity (mass flow rate) through varying the compressor's intake volume. The slide valve is attached to a piston, which is moved by controlling the gas pressure in the piston's cylinder. The slide valve is aptly named, since it moves by sliding axially along the outside surface of the two mating rotors. The pressure in the slide valve's piston cylinder and thus its position of the slide valve, is controlled by the slide valve load and unload solenoid valves. The slide valve allows modulated capacity from about 25% to 100% of full load tonnage. Since the piston must overcome static friction and force balances, it can only be effectively moved while the compressor is running creating differential pressure. To prevent starting at a partially loaded point, the compressor must be allowed to perform a run un-load just prior to shutdown, if at all possible.

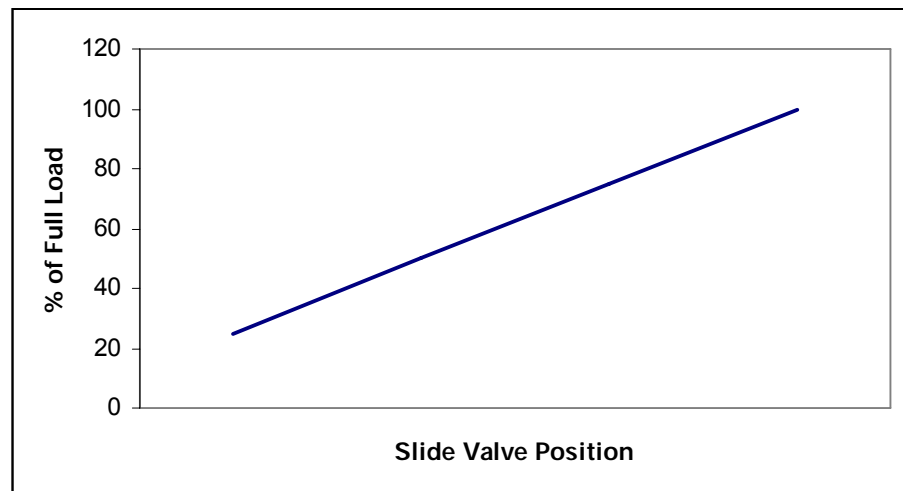


Figure 30. Compressor Capacity

Checkout Procedure for the Load-Unload Outputs

A dual triac LLID (1A5) controls the load and unload solenoid valve on the compressor with 115VAC triacs (solid state relays). Unlike mechanical relays however, a triac has a rather high leakage current when off, comparatively speaking. While the leakage is not nearly enough to actuate a solenoid valve, it may under a no load condition (as would be experienced when a solenoid coil



Compressor Capacity - RTHD

fails open), look like it was stuck “on” when using a voltmeter to test it. Thus it is important to verify that the solenoid coil is continuous and providing a normal load or to connect a known good load, such as a low wattage 115 Volt lamp, to the terminals when testing the outputs. Refer to the wiring diagrams in the control panel for the following procedure.

⚠ WARNING Live Electrical Components!

During installation, testing, servicing and troubleshooting of this product, it may be necessary to work with live electrical components. Have a qualified licensed electrician or other individual who has been properly trained in handling live electrical components perform these tasks. Failure to follow all electrical safety precautions when exposed to live electrical components could result in death or serious injury.

With a particular compressor running, the triacs may be checked by measuring voltage from terminal J3-1(load) and J2-1 (unload) to neutral. The triacs operate in the high side and switch 115 VAC power to J3-1 (load solenoid) or J2-1 (unload solenoid) to move the slide valve in the appropriate direction. Except during compressor starts and stops, in normal operation, the solenoid valves can only be energized for a period of between 40 and 400 milliseconds once every 6 seconds. Often, if the chilled water setpoint is being met under steady state conditions, they may not be energized at all. To assure loading and unloading is occurring it may be necessary to make slight adjustments to the chilled water setpoint to force the action. As the pulsed on-time is potentially short it may be difficult to see, especially if using a meter movement type voltmeter. Use of a low wattage 115 VAC lamp may be of some help for a visual indication of output triac operation.

When a triac is off, about 3 VAC or less should be measured on its terminal with the solenoid load connected. When it is on, the voltage should be close to 115 VAC (the drop across the triac is about 1-2 volts).

The best time to check the unload solenoid is immediately after the compressor starts. For the first 45 seconds (30 seconds in ice making) after the start the unload solenoid should be energized continuously.

Checking the load solenoid is more difficult. 45 seconds after the start, the compressor will usually start to load until the water temperature is satisfied. Remember however, that certain limit conditions may prevent the compressor from loading even if the chilled water setpoint is not satisfied.

Checkout procedure for the Slide Valve and Load-Unload Solenoids

Make sure unit is off and there is no power in the control panel before beginning this procedure.

⚠ WARNING Hazardous Voltage!

Disconnect all electric power, including remote disconnects before servicing. Follow proper lockout/tagout procedures to ensure the power can not be inadvertently energized. Failure to disconnect power before servicing could result in death or serious injury.

⚠ WARNING
Live Electrical
Components!

During installation, testing, servicing and troubleshooting of this product, it may be necessary to work with live electrical components. Have a qualified licensed electrician or other individual who has been properly trained in handling live electrical components perform these tasks. Failure to follow all electrical safety precautions when exposed to live electrical components could result in death or serious injury.

1. Connect to unit with TechView. Take manual control of the slide valve.
Change slide valve control from auto to manual. Increase the slide valve duty cycle to load and decrease to unload.
2. Connect a manifold gauge set to the schrader valve located at the end of the piston housing. This schrader allows access to the pressure behind the male piston. Refer to [Figure 31](#).

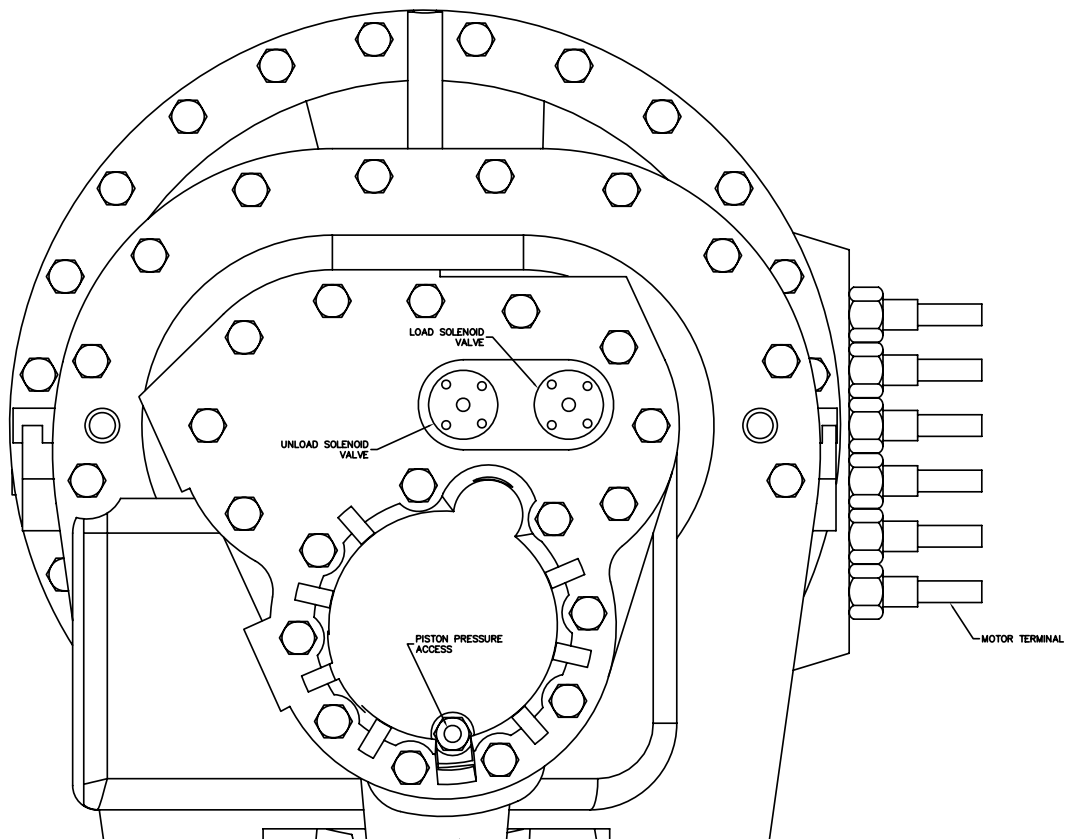


Figure 31. CHHC Compressor



Compressor Capacity - RTHD

3. Place the chiller in "Auto" mode and provide all necessary interlocks and a load to start the chiller
4. Allow the compressor to start and monitor the compressor currents with a clamp-on type ammeter.

Load

1. Once the compressor has started, allow the Unload solenoid to remain energized for approximately 45 seconds, then manually load the compressor (using UCP2 or TechView). Record the male piston pressure and compressor currents.
2. Monitor the male pressure behind the piston and the amp draw of the unit. Both should gradually increase with each pulse of the load solenoid.

Note: All limits are still active. If the chiller enters into a condenser, current, or evaporator limit. Continuously monitor the operating mode.

Unload

1. Manually Unload the compressor using the front panel or TechView.
2. The pressure behind the male piston and the RLA of the unit should gradually decrease with each pulse sent to the unload solenoid.

Note: The pressure behind the piston should be approximately suction pressure when the compressor is fully unloaded. The RLA will be dependent on the application.

With the results from the above checkout procedure use [Table 8](#) to determine the possible causes of the loading problem..

Table 8. Possible Causes to Loading Problem

Possible Operation	Recorded Measurement	Load	Unload	Hold
Operating properly	Piston Pressure	increase	decrease	remain constant
	Amp Draw	increase	decrease	remain constant
Stuck piston	Piston Pressure	increase	decrease	remain constant
	Amp Draw	remain constant	remain constant	remain constant
Leaking load solenoid, internal leak or leaking piston	Piston Pressure	increase	may drop initially but will increase as soon as the unload is de-energized	increase
	Amp Draw	increase	may drop initially but will increase as soon as the unload is de-energized	increase
Leaking unload solenoid	Piston Pressure	remain constant or decrease	decrease	decrease
	Amp Draw	remain constant or decrease	decrease	decrease

Compressor Capacity - RTAC

The CHHP (GPII) compressor is a “screw” or helical rotor design with two rotors, one directly driven by the motor called the male and the other driven by the lobes of the male called the female.

CHHP compressors have a female step load solenoid valve and male load/unload solenoid valves that are utilized for capacity control. The female step load solenoid is so named because it acts on the female rotor side of the compressor, and its function is to “pilot” a larger valve inside the compressor that opens to bypass compressed vapor back to the suction of the compressor. This bypass action causes a “step” difference in the capacity of the compressor.

On the Male rotor side of the compressor is the male port unloader piston, which can move laterally along the male rotor. Small bypass ports in the rotor housing are covered and uncovered by the unloader piston as it moves. The position of the piston, is controlled by two direct acting solenoid valves called the male load and male unload solenoid valves. These valves add or vent pressure to the cylinder of the movable piston to position and “modulate” the amount of compressed vapor that can be bypassed back to suction.

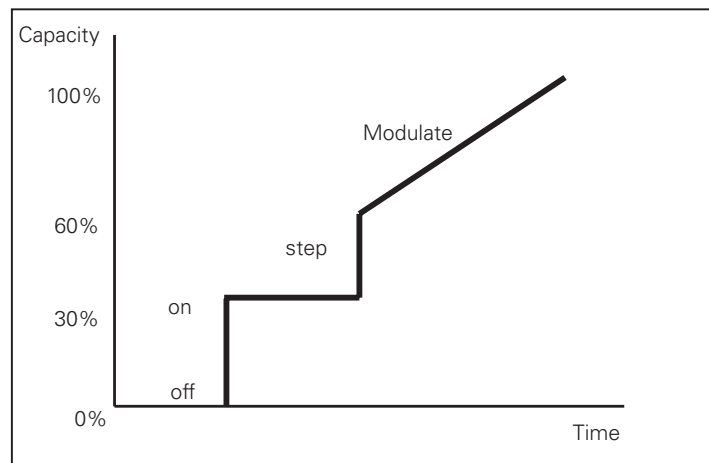


Figure 32.Compressor Capacity

With the female solenoid de-energized (internal female bypass valve open), the minimum capacity of the compressor is 30% of full load. With the female solenoid valve energized, (and the male port unloader in the unloaded position) the compressor capacity jumps up to approximately 60%. Through pulsed control of the male load and unload solenoid valves, the piston can be moved to exactly modulate the load of the compressor from 60 to 100% of its capacity. There are no springs acting on the male port unloader piston, and as such, the piston can only be effectively moved while the compressor (or manifolded compressor) is running, creating differential pressure.

Checkout Procedure for the Female Step Load Outputs

A dual triac LLID (1U17, 2U17,) controls the female solenoid valve on the compressor with a 115VAC relay output. Refer to the wiring diagrams in the control panel for the following procedure.

⚠ WARNING
Live Electrical Components!

During installation, testing, servicing and troubleshooting of this product, it may be necessary to work with live electrical components. Have a qualified licensed electrician or other individual who has been properly trained in handling live electrical components perform these tasks. Failure to follow all electrical safety precautions when exposed to live electrical components could result in death or serious injury.

With a particular compressor running, the relay may be checked (under load) by measuring the voltage for terminal J2-1 or J3-1 to neutral. The relay operators in the high side and switches power to J2-1 and/or J3-1, to move the female step load valve to the loaded position. When CH530 decides to load the compressor, the female step load is energized continuously. To assure that loading is occurring, it may be necessary to make slight adjustments to the chilled water setpoint to force the action.

Checkout Procedure for the Step Load Solenoids Valve and Piston

- 1 Connect a manifold gauge set to the schrader valve located at the side of the piston housing. Refer to [Figure 33](#). This schrader allows access to the back side of the step load piston and, therefore, will allow direct measurement of the pressure that actuates the step load valve.
- 2 Observe the pressure during a compressor start. Initially, the pressure should drop to suction pressure. The compressor will run unloaded for at least 45 seconds.
- 3 When the CH530 begins to load the compressor the solenoid will actuate and supply discharge pressure to the piston.
- 4 If after verifying the 115 VAC has been applied to the step load solenoid, the pressure does not increase to discharge pressure, the step load solenoid coil and/or the valve must be replaced.

The percent RLA of the compressor should increase. If the percent RLA does not increase, the step load valve is stuck and compressor should be replaced.

Note: All limits and safeties are still active. If the chiller enters into a condenser, current, or evaporator limit. Continuously monitor the operating mode.

Checkout Procedure for the Male Load-Unload Outputs

A dual triac LLID (1U16, 1U21, 2U16, 2U21) controls the load and unload solenoid valve on the compressor with a 115VAC triacs (solid state relays). Unlike mechanical relays however, a triac has a rather high leakage current when off, comparatively speaking. While the leakage is not nearly enough to actuate a solenoid valve, it may under a no load condition (as would be experienced when a solenoid coil fails open), look like it was stuck "on" when using a voltmeter to



Compressor Capacity - RTAC

test it. Thus it is important to verify that the solenoid coil is continuous and providing a normal load or to connect a known good load, such as a low wattage 115 Volt lamp, to the terminals when testing the outputs. Refer to the wiring diagrams in the control panel for the following procedure.

⚠ WARNING Live Electrical Components!

During installation, testing, servicing and troubleshooting of this product, it may be necessary to work with live electrical components. Have a qualified licensed electrician or other individual who has been properly trained in handling live electrical components perform these tasks. Failure to follow all electrical safety precautions when exposed to live electrical components could result in death or serious injury.

With a particular compressor running, the triacs may be checked by measuring voltage from terminal J3-1(load) and J2-1 (unload) to neutral. The triacs operate in the high side and switch 115 VAC power to J3-1 (load solenoid) or J2-1 (unload solenoid) to move the slide valve in the appropriate direction. Except during compressor starts and stops, in normal operation, the solenoid valves can only be energized for a period of between 40 and 400 milliseconds once every 6 seconds. Often, if the chilled water setpoint is being met under steady state conditions, they may not be energized at all. To assure loading and unloading is occurring it may be necessary to make slight adjustments to the chilled water setpoint to force the action. As the pulsed on-time is potentially short it may be difficult to see, especially if using a meter movement type voltmeter. Use of a low wattage 115 VAC lamp may be of some help for a visual indication of output triac operation.

When a triac is off, about 3 VAC or less should be measured on its terminal with the solenoid load connected. When it is on, the voltage should be close to 115 VAC (the drop across the triac is about 1-2 volts).

The best time to check the unload solenoid is immediately after the compressor starts. For the first 45 seconds (30 seconds in ice making) after the start the unload solenoid should be energized continuously.

Checking the load solenoid is more difficult. 45 seconds after the start, the compressor will usually start to load by energizing the female load solenoid. Then the male solenoid will begin to pulse until the water temperature is satisfied. Remember however, that certain limit conditions may prevent the compressor from loading even if the chilled water setpoint is not satisfied.

Checkout procedure for the Slide Valve and Load-Unload Solenoids

Setup

Make sure unit is off and there is no power in the control panel before beginning this procedure.

⚠ WARNING Hazardous Voltage!

Disconnect all electric power, including remote disconnects before servicing. Follow proper lockout/tagout procedures to ensure the power can not be inadvertently energized. Failure to disconnect power before servicing could result in death or serious injury.

- 1 Identify the LLID associated with the compressor to be tested (1U16, 1U21, 2U16, 2U21). Disconnect the wires, take care to identify the wires to prevent cross wiring when reconnecting.
- 2 Install a toggle switch between the Control power HOT to the load and unload leads (previously connected to J3-1 and J2-1).
 1TB5-1, 2TB5-1 Hot
 1TB5-16, 2TB5-16 Neutral
 Initially make sure that the Load toggle switch is open and the Unload toggle switch is closed.
- 3 Connect a manifold gauge set to the schrader valve located at the end of the piston housing. This schrader allows access to the pressure behind the male piston. Refer to [Figure 33](#).

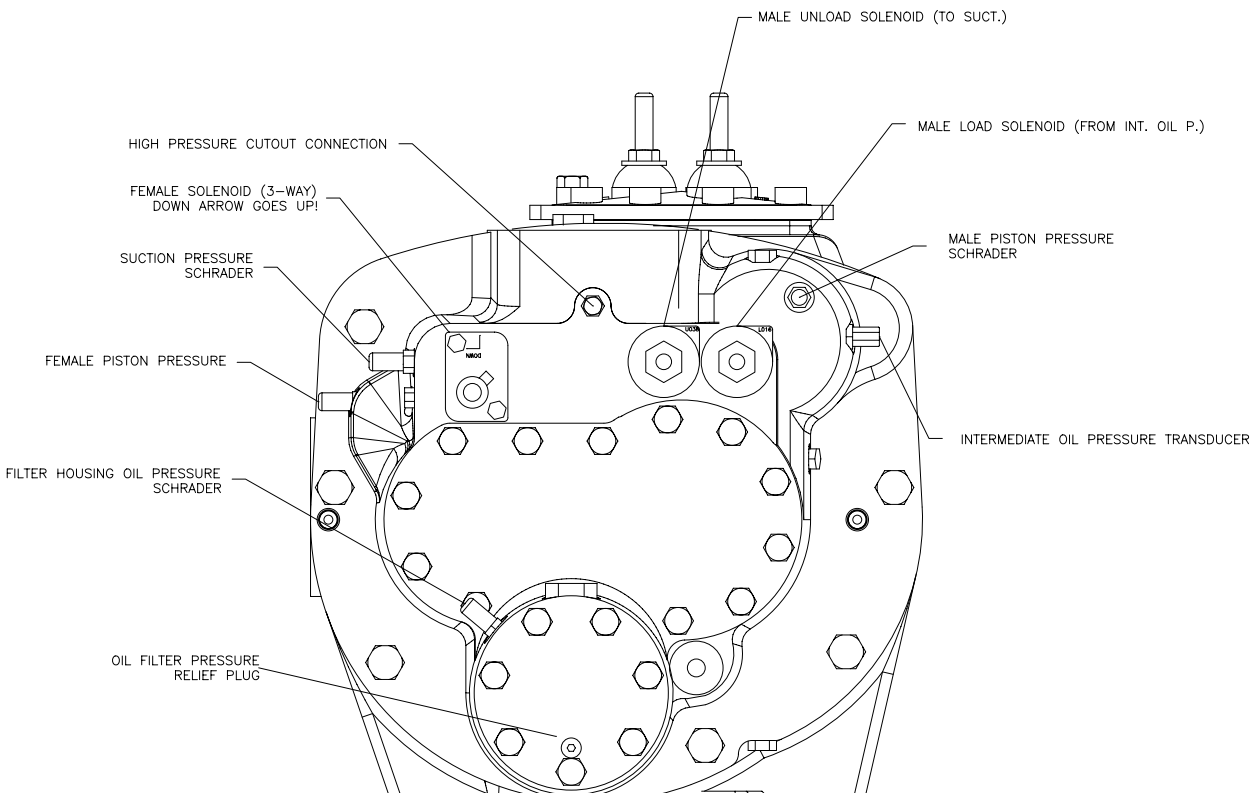


Figure 33.CHHP Compressor

- 4 Re-apply power to the unit and place the chiller in the "stop" mode. Using techview lockout all compressors except the compressor to be tested. Place the chiller in "Auto" mode and provide all necessary interlocks and a load to start the chiller

⚠ WARNING
Live Electrical
Components!

During installation, testing, servicing and troubleshooting of this product, it may be necessary to work with live electrical components. Have a qualified licensed electrician or other individual who has been properly trained in handling live electrical components perform these tasks. Failure to follow all electrical safety precautions when exposed to live electrical components could result in death or serious injury.

- 5 Allow the compressor to start and monitor the compressor currents with a clamp-on type ammeter.

Load

- 1 Once the compressor has started, allow the Unload solenoid to remain energized for approximately 45 seconds, then open the Unload toggle switch to de-energize the valve. Verify that at least one condenser fan is on before continuing with the checkout, as low differential refrigerant pressure will preclude proper Slide Valve operation. Record the male piston pressure and compressor currents.
- 2 Manually close and open the Load toggle switch to energize the Load Solenoid in 4 to 5 short "pulses". Each load pulse should be approximately one second in duration, with approximately 10 seconds between pulses.
- 3 Monitor the male pressure behind the piston and the amp draw of the unit. Both should gradually increase with each pulse of the load solenoid.

Note: All limits are still active. If the chiller enters into a condenser, current, or evaporator limit. Continuously monitor the operating mode.

Unload

- 1 Manually close the Unload toggle switch to continuously energize the Unload Solenoid valve.
- 2 The pressure behind the male piston and the RLA of the unit should gradually decrease with each pulse sent to the unload solenoid.

Note: The pressure behind the piston should be approximately suction pressure when the compressor is fully unloaded. The RLA will be dependent on the application.

With the results from the above checkout procedure use [Table 9](#) to determine the possible causes of the loading problem.

Table 9. Possible Causes to Loading Problem

Possible Operation	Recorded Measurement	Load	Unload	Hold
Operating properly	Piston Pressure	increase	decrease	remain constant
	Amp Draw	increase	decrease	remain constant
Stuck piston	Piston Pressure	increase	decrease	remain constant
	Amp Draw	remain constant	remain constant	remain constant
Leaking load solenoid, internal leak or leaking piston	Piston Pressure	increase	may drop initially but will increase as soon as the unload is de-energized	increase
	Amp Draw	increase	may drop initially but will increase as soon as the unload is de-energized	increase
Leaking unload solenoid	Piston Pressure	remain constant or decrease	decrease	decrease
	Amp Draw	remain constant or decrease	decrease	decrease

Electronic Expansion Valve

The Electronic Expansion Valve (EXV) is a flow device which regulates the flow of refrigerant to the evaporator in order to match the compressor capacity. This function increases the part load efficiencies.

The EXV is positioned by a 24VDC three phase bipolar stepper motor. The electronics to drive the stepper motor are integral to the motor housing. The position of the valve is determined by main processor calculations based on the liquid level control algorithm. If the liquid level rises above the optimum value of 0.0" as displayed on the MP, the EXV will begin to close. If the liquid level falls below the optimum value, the EXV will begin to open. To adjust the position of the EXV, the main processor communicates a step value (0-6386 steps) command to the EXV via the LLIDs bus cable.

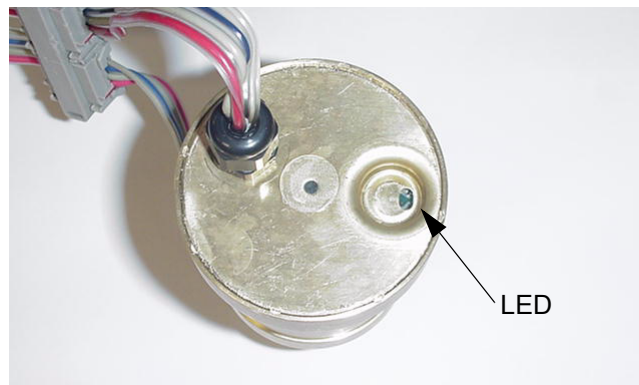


Figure 34. Top of EXV

EXV Checkout Procedure

Is the EXV bound and communicating?

Connect TechView and get into Binding View. This will shut the chiller down. Once in Binding View, verify that the EXV is bound.

Note: Please refer to Service Tool for questions concerning binding LLIDs and getting into Binding View.

If there are multiple LLIDs that are not verified go to IPC troubleshooting.

If the EXV is not bound, try to bind it. If the EXV will not bind, it could be a problem with the connector or the EXV itself. Take a close look at the connector to make sure that all four wires are securely in place. It may be necessary to remove the cap to check for broken or misplaced wires.

CAUTION
Equipment
Damage Possible!

All unit built before October 1, 2002 (U02#####) used connectors that must be replace if the cap is removed. If the cap is removed on any of these units cut out

the old connector and splice in a new section of cable and a new connector. See Section 2-IPC Overview for instruction on installing a new cap.

If the EXV is bound, try to turn the LED on with a magnet. If the light will not turn on, there could be a problem with the EXV. Try to turn the light on in Binding View. With the light on, hold the magnet to the LED. The LED should get brighter. If it doesn't get brighter, this may indicate a problem with the EXV or the connector. Take a close look at the connector to make sure that all four wires are securely in place. It may be necessary to remove the cap to check for broken or misplaced wires.

If there is no problem found with the connector and the EXV will not bind, then replace the EXV.

Is the EXV functioning properly?

The EXV goes to the closed position at a normal shutdown. There is a sight glass in the body of the valve to monitor EXV position. Refer to [Figure 35](#).

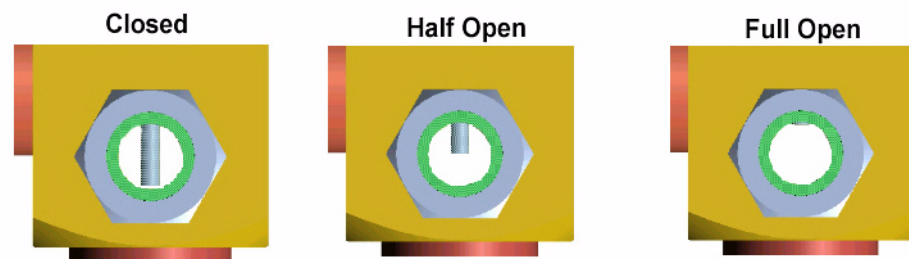


Figure 35.EXV Position

- 1 Shut the chiller down.
- 2 Lock out the circuit. This can be done using DynaView under the setpoint tab or in TechView under the Compressor Service View. Refer to [Figure 36](#). With the circuit shut down the valve should go to the closed position. Note the EXV position.
- 3 Using TechView under Compressor Service View, open the EXV. Look at the EXV position. The valve should go to the open position. Refer to [Figure 36](#).
- 4 The valve should go from closed to full open. If the valve does not move or open fully, replace the valve.

It is very important to confirm that the valve is bound and communicating on the LLID bus before it is replaced.

- 5 Place the valve back into the auto mode of operation.

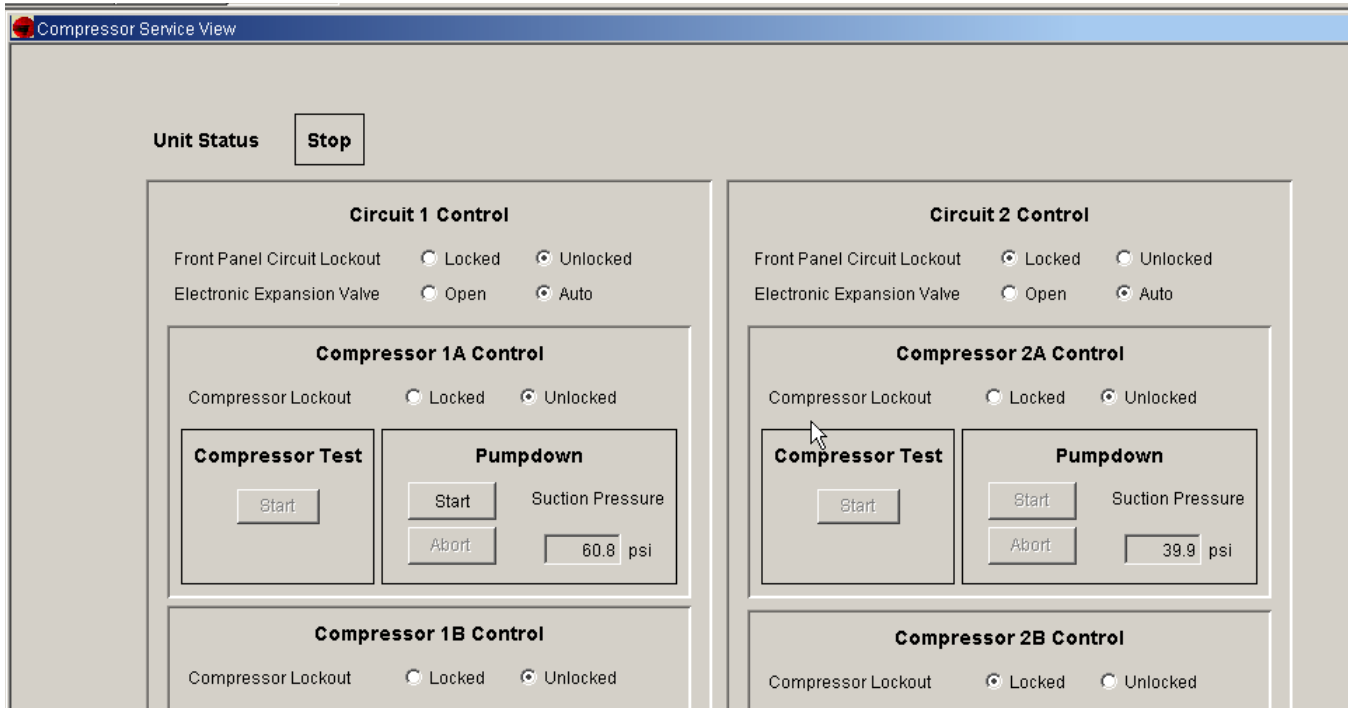


Figure 36.: Compressor Service View RTAC

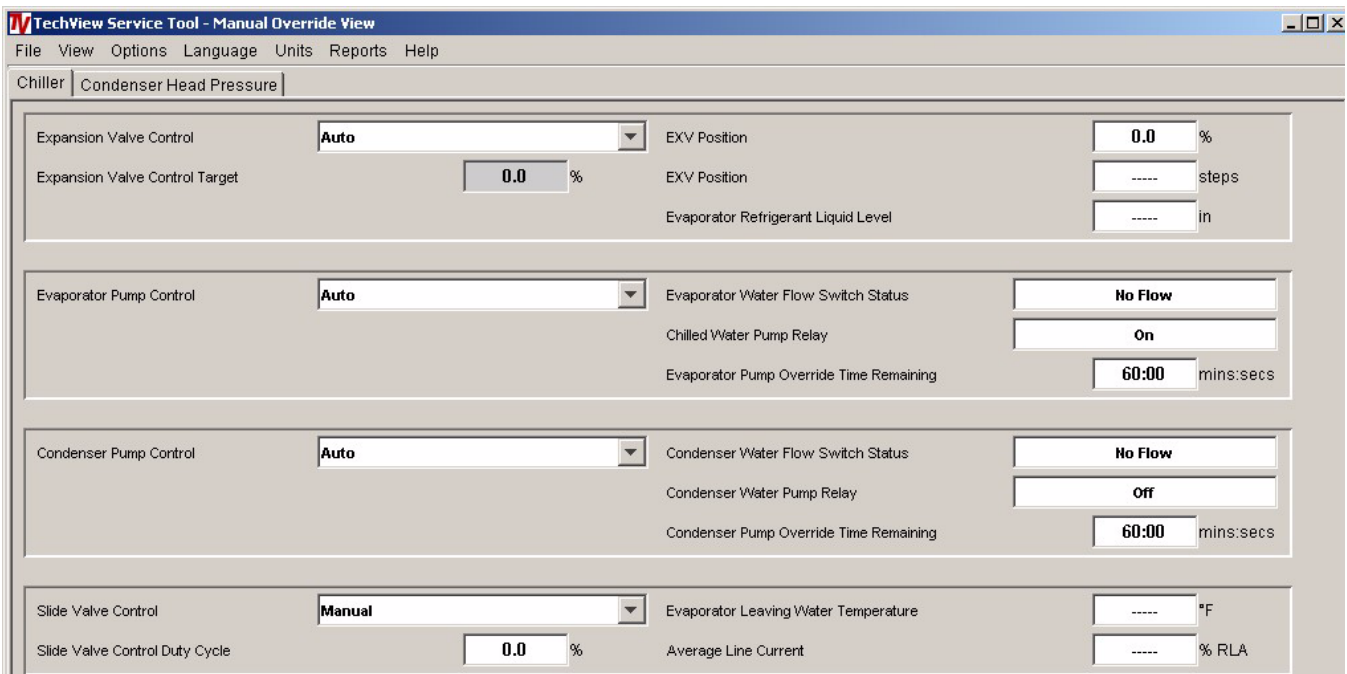


Figure 37. Manual Override View - RTHD



Liquid Level Sensor

The liquid level sensor is mounted in a small tank or canister attached to the outside of the tube sheet. The evaporator's liquid level is transmitted into the tank through a small vapor and liquid line.

The liquid level sensor is required to provide input for control of the EXV, which allows the regulation of refrigerant flow into the evaporator, to match the compressor capacity. This provides for increased part load efficiencies compared to a fixed orifice device.

There are two types of sensors that are used on RTAC and RTHD units. A float type sensor with an external LLID was originally used on RTAC and RTHD units. A capacitance based with an internal LLID will soon be used on all units.

External LLID Sensor

The sensor consists of a body made from an enclosed tube and fitting, and a magnetic float which slides over the tube. Internal to the tube, and isolated from the refrigerant, is a narrow PC board with a resistor and magnetic reed switch array. The float's magnets close the reed switches pattern as it moves up the tube, creating a changing resistance (and ultimately a direct acting DC output voltage) similar to that of a potentiometer

Internal LLID

This new level sensor is a capacitive based switch. This switch is more reliable and has no moving parts. It is less sensitive to foam and will provide consistent operation across the operating map. This new sensor can be installed on existing chillers using an adapter.

There are 2 capacitor sensors in the copper tube. The lower sensor is used to determine the capacitance of the liquid (refrigerant and oil mixture). The upper sensor is used to determine the height of the liquid in the evaporator.

Liquid Level Sensor Checkout Procedure

Is the sensor bound and communicating?

Connect TechView and get into Binding View. This will shut the chiller down. Once in Binding View verify that the Liquid Level Sensor is bound.

Note: Please refer to Service Tool for questions concerning binding LLIDs and getting into Binding View.

If there are multiple LLIDs that are not verified go to IPC troubleshooting.

If the sensor is not bound, try to bind it. If the sensor will not bind, it could be a problem with the connector or the sensor itself. Take a close look at the connector to make sure that all four wires are securely in place. It may be necessary to remove the cap to check for broken or misplaced wires.



Liquid Level Sensor

CAUTION Equipment Damage Possible!

All unit built before October 1, 2002 (U02#####) used connectors that must be replaced if the cap is removed. If the cap is removed on any of these units cut out the old connector and splice in a new section of cable and a new connector. See Section 2-IPC Overview for instruction on installing a new cap.

If the sensor is bound, try to turn the LED on with a magnet. If the light will not turn on there could be a problem with the sensor. Try to turn the light on in Binding View. With the light on, hold the magnet to the LED. The LED should get brighter. If it doesn't get brighter this may indicate a problem with the sensor, connector, or bus. Take a close look at the connector to make sure that all four wires are securely in place. It may be necessary to remove the cap to check for broken or misplaced wires. If there is no problem found with the connector, and the sensor will not bind, then replace the sensor.

Is the sensor reading accurately?

In order for this test to work, the condenser pressure must be at least 60 psi greater than the evaporator pressure.

- 1 Run the circuit to increase differential pressure.
- 2 Shut the unit down. Close the liquid line service valve. Place a gage on the suction line (the gage is a secondary check to verify that suction transducer is reading correctly). Enable pump down (the unit must be in the stopped mode to enable pump down). This can be done from either DynaView (Set Points tab) or TechView (Compressor Service View). Pump down will be automatically terminated when the suction pressure reaches 5 psig.

If the ambient temperature is below 50 deg F the unit will do an operational pumpdown just before shut down. This operational pumpdown is only active on units with software version 18 and later and design sequence B0 and later. If the unit does a pumpdown skip step 2.

- 3 During pump down watch the liquid level.
RTAC- This can be done in TechView in Status View under the Circuit tab or on the DynaView (software version 18 and later only) on the refrigerant tab.
RTHD- This can be done in TechView in Status View under the Circuit tab or on the DynaView on the reports tab under evaporator.
- 4 The liquid level should go to -1.1 or less as the refrigerant is removed from the evaporator.
- 5 As soon as pump down is complete, open the expansion valve.
- 6 RTAC - This can be done from the DynaView on the Set Point tab or in TechView in Compressor Service View.
- 7 RTHD- This can be done from the DynaView on the Settings tab under Manual Control Settings or in TechView in Compressor Service View.
- 8 With the valve open, the liquid level should increase. Depending on operating conditions, the level may not go all the way to +1.0 or more, but the level should increase.
- 9 If there is no change in the liquid level during this test there may be problem with the liquid level sensor, canister, or the lines going to the canister.



Gas Pump - RTHD Only

Residual oil in a falling film evaporator will not immediately be recovered by the oil separators and will eventually log in the evaporator. Oil cannot be returned as oil/liquid droplets pulled up the suction line of the compressor. The oil is instead returned by alternatively filling and draining a small tank with refrigerant from the bottom of the evaporator. The fill cycle is controlled by energizing the fill solenoid valve which vents the tank back to the evaporator, allowing a gravity feed of liquid through a check valve into the tank. This refrigerant which has anywhere from 3% to 8% oil, is then drained by energizing the drain valve which applies condenser pressure to the tank thus "pushing" the liquid up a line which drains directly to the suction of the compressor. The check valve prevents the liquid or high pressure gas from re-entering the evaporator. The solenoid valves are controlled directly by the CH530.

Gas Pump Checkout Procedure - Unit Off

To check the operation of the Gas Pump while the chiller is OFF do the following:

- 1 Turn off chiller.
- 2 Close (front seat) the ¼" angle valve downstream of the "cold" filter.
- 3 Back seat valve and Install gauge. Re-open to read pressure
- 4 Close the ¼" angle valve on the condenser which supplies the Gas Pump.
- 5 Make sure the gas pump solenoid valves are de energized.
- 6 Pressurize the line between the Gas Pump and the ¼" angle valve upstream of the "cold" filter using POE oil taken from the oil sump. If desired, refrigerant from the condenser can be used as well.
- 7 Pressurize the line to approximately 115 psi.
- 8 Monitor the pressure leak rate in the line. It's typical to see an immediate 5 psi drop in pressure, and then a slow drop thereafter. A normal leak rate is 10 psi in 5 minutes. A rapidly falling pressure may indicate a leaking check valve, but may also indicate a leaking solenoid valve. Further testing may be necessary to determine which component is leaking.
- 9 Before returning to service, make sure all valves and coils are returned to their normal positions.



Gas Pump Checkout Procedure - Unit On

To check the operation of the Gas Pump while the chiller is ON do the following procedure:

Note: At least a 50 psi differential must exist between the evaporator and condenser before performing this test.

- 1 Turn the compressor off and close the valve on the oil return line from the Gas Pump to the compressor.
- 2 Back seat valve and install gauge. Re-open to read pressure.
- 3 Allow the unit to start.
- 4 Allow the Gas Pump to enter and complete a "fill" cycle (fill solenoid will energize).
- 5 Allow the Gas Pump to enter a "drain" cycle (fill solenoid will de-energize and drain solenoid will energize). During the drain cycle de-energize the fill solenoid. Unplug J3-1 and J3-2 from the 1A6. Verify that the correct coil is de-energized. Or remove the electric coil from the valve (to disable the valve) and place a screwdriver or bolt shaft through the coil center to prevent overheating of the coil.
- 6 Monitor the gauge pressure at angle valve. The pressure should build toward condensing pressure. At the completion of the drain cycle de-energize the drain solenoid. Unplug J2-1 and J2-2 from the 1A6. Verify that the correct coil is de-energized. Or remove the electric coil from the drain valve to disable the valve and place a screwdriver or bolt shaft through the coil center to prevent overheating of the coil. If the pressure holds to within 10 psi in 5 minutes, the system is functioning normally.
- 7 If the pressure fails to hold near condensing pressure, there may be a solenoid valve or a check valve leakage.
- 8 If the pressure falls rapidly to or near suction, either the "fill" solenoid or the check valve is leaking by.
- 9 To determine if the check valve is leaking by, place a temperature probe on each side of the check valve. Monitor the temperature differential across the check valve during the time that the "drain" solenoid is energized. If the check valve is leaking, the temperature differential will be very small because condensing gas will push into the evaporator. In a properly operating system, the temperature differential across the check valve during the drain cycle will be about 2-4 degrees depending on operation conditions.
- 10 If step 8 shows that there is a leak, but step 9 indicates it is NOT related to the check valve, the problem most likely resides in the "fill" solenoid, and it should be replaced.
- 11 Before returning to service, make sure all valves and coils are returned to their normal positions.



Optical Sensor - RTHD Only

The oil level detector is located in the oil sump. The sensor uses infrared light reflected off the inside of a conical prism, back to a detector to sense the difference in refractive index of the prism /oil interface relative to that of the prism/vapor interface.

Checkout Procedure

CAUTION Compressor Damage!

Never perform this test while the compressor is running. Turn the chiller off and ensure that the compressor will not start.

- 1 Verify that the wiring between the Optical Sensor on 1A11 J2-1, 2 and 1A3 J3-1 is correct.
- 2 Remove the sensor from the oil sump.
Units with a design sequence of A0 to D0, remove the snap ring securing the sensor in the sump to remove the sensor.
Units with a design sequence of E0 to present, unscrew the sensor in the oil sump to remove the sensor.
Note: The optical sensor is separated from the refrigerant by a clear prism, therefore, it is not necessary to recover refrigerant when removing the sensor.
- 3 Place a mirror or white piece of paper ¼" from the face of the sensor.
- 4 On the CH530 DynaView read the status of the oil loss sensor.
- 5 The Oil Loss Level Sensor Status is on the reports tab under the compressor sub-menu.
- 6 Place a piece of black electrical tape directly on the face of the sensor. After 10 seconds, the status should read 'WET'
- 7 If the status does not change, disconnect the sensor leads from the 1A11 J2-1, 2 and 1A3 J3-1. Connect a 1.5 volt battery directly to 1A11 at J2-1 and J2-2. After 10 seconds, the status should read 'WET'. If so, proceed to Step 7. If the status still reads 'DRY', the Chiller Module is defective and needs to be replaced.
- 8 If the status reads 'WET', connect a 24 VDC power supply to 1A11 at J2-1 and J2-2. After 10 seconds, the status should change to 'DRY'. If the status does not change, the 1A11 is defective and needs to be replaced. If the status reads correctly, the Optical Sensor is defective and needs to be replaced.



TechView Service Tool

Tracer CH530 is a new chiller controller technology developed by Trane for use on large chiller products and is serviced with a PC (laptop)-based tool. Technicians that make any chiller control modification or service any diagnostic with Tracer CH530 must use a laptop running the software application "TechView." TechView is a Trane application developed to minimize chiller downtime and aid the technicians' understanding of chiller operation and service requirements.

The TechView service tool is used to load software into the Tracer CH530 main processor (DynaView or EZView). TechView is also used to perform CH530 service and maintenance functions. Servicing a CH530 main processor includes:

- Updating main processor software
- Monitoring chiller operation
- Viewing and resetting chiller diagnostics
- Low Level Intelligent Device (LLID) replacement and binding
- Main processor replacement and configuration modifications
- Setpoint modifications
- Service overrides

TechView is available for download on Trane.com at no cost. Minimum Laptop requirements are listed below. The version of TechView will be updated periodically and laptop requirements may change. Please refer to Trane.com for the latest information.

Software Requirements

TechView software versions are available from the TechView Software Download page. A new installation requires two software applications: Java Runtime Environment (JRE) and TechView itself.

Tracer CH530 main processor software versions are available from the Tracer CH530 Main Processor Download page. Main processor software is unique per product family.

Hardware Requirements

Specific hardware requirements have been established for service technician laptops that will be using TechView with Tracer CH530.



Laptop requirements for CH530

- Pentium II, III, or higher processor
- 128MB RAM
- 1024x768 resolution
- CD-ROM
- 56K Modem
- 9-pin RS232 serial port connection
- 25-pin LPT1 parallel port connection
- Windows 2000
- Microsoft Office (MS Word, MS Access, MS Excel)

The Download Process

Installing the TechView service tool and main processor software is a two-step process.

Users must first download the TechView and main processor installation utility files.

A new installation of TechView requires two software applications: Java Runtime Environment (JRE) and TechView itself. The installation utilities for these applications may be obtained from the TechView Software Download page.

Returning users and those continuing the initial downloading process must then download the main processor installation utility. The installation utility for these applications is available from the Tracer CH530 Main Processor Download page.

After downloading the TechView and main processor installation utility files, the user must execute the utility files to actually install the programs on the PC.

Instructions for First Time Tracer™ CH530 Users

- 1 Create a folder called "CH530" on your C:\ drive. You will select and use this folder in subsequent steps so that downloaded files are easy to locate.
- 2 Download the Java Runtime installation utility file onto your PC in the CH530 folder (please note that this does not install Java Runtime, it only downloads the installation utility).

Click on the latest version of Java Runtime shown in the TechView Download table.

Select "Save this program to disk" while downloading the files (do not select "Run this program from its current location").

- 3 Download the TechView installation utility file onto your PC in the CH530 folder (please note that this does not install TechView, it only downloads the installation utility).

Click on the latest version of TechView shown in the TechView Download table.



TechView Service Tool

Select "Save this program to disk" while downloading the files (do not select "Run this program from its current location").

- 4 Remember where you downloaded the files (the "CH530" folder). You will need to locate them to finish the installation process.
- 5 Proceed to "Main Processor Software Download" page and read the instructions to download the latest version of main processor installation files.
- 6 Note: you will first select the chiller type to obtain the available file versions.
- 7 Select the product family. A table with the download link will appear for that product family.
- 8 Download the main processor software onto your PC in the CH530 folder (please note that this does not install the main processor, it only downloads the installation utility).

To do this, click on the latest version of the main processor.

Select "Save this program to disk" while downloading the files (do not select "Run this program from its current location").

- 9 Remember where you downloaded the files (the "CH530" folder). You will need to locate them to finish the installation process.
- 10 To complete the installation process, locate the installation utilities you downloaded into the CH530 folder. If necessary, use your PC's file manager to locate the downloaded files.
- 11 Install the applications in the following order by double-clicking on the install program and following the installation prompts:
 - Java Runtime Environment (JRE_VXXX.exe)
Note: During the Java Runtime Environment installation, you may be prompted to "select the default Java Runtime for the system browsers...". Do not select any system browsers at this step. There should be no default browsers selected for proper operation.
 - TechView (6200-0347-VXXX.exe)
The main processor (6200-XXXX-XX-XX.exe).
The main processor program will self extract to the proper folder within the TechView program directory, provided the TechView program is properly installed on the C:\ drive.
- 12 Connect your PC to the CH530 main processor using a standard 9-pin male/9-pin female RS-232 cable.
- 13 Run the TechView software by selecting the TechView icon placed on your desktop during the installation process. The "Help...About" menu can be viewed to confirm proper installation of latest versions.

Using TechView

- 1 Connect laptop to the Main Processor using a RS232 serial cable. Refer to Figure 38.



Figure 38. TechView Connection

- 2 A TechView icon has been placed on the computers desktop. Double click on the icon to begin using TechView.

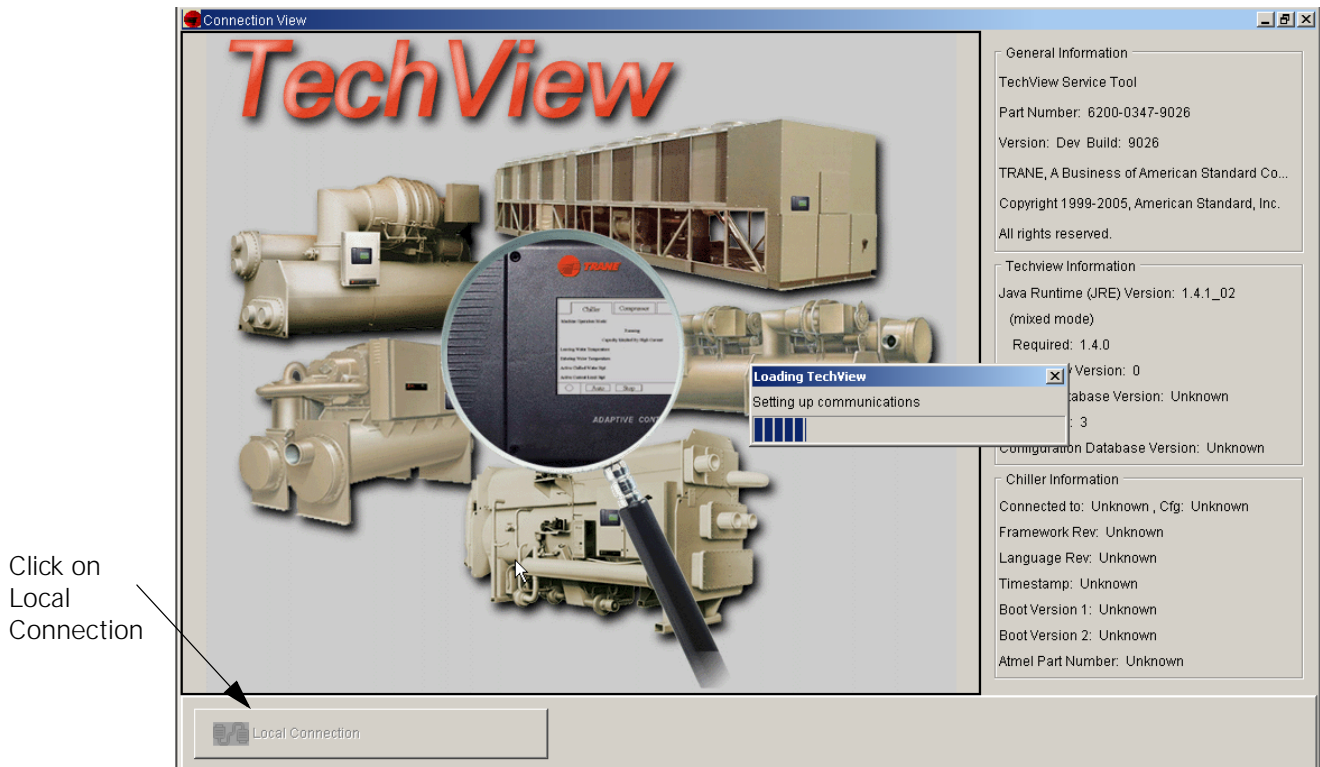


Figure 39. Connection Screen



Trane
A business of American Standard Companies
www.trane.com

For more information, contact your local Trane office or e-mail us at comfort@trane.com

Literature Order Number	RLC-SVD05A-EN
-------------------------	---------------

Date	November 2005
------	---------------

Supersedes	RTAC-SVD01A-EN
------------	----------------

Stocking Location	Inland
-------------------	--------

Trane has a policy of continuous product and product data improvement and reserves the right to change design and specifications without notice.
